

Jonathan Richter

{Sketchbook pages from 1994-2008}

Shut Your Cake Hole



GIDDY

WHIPPEE

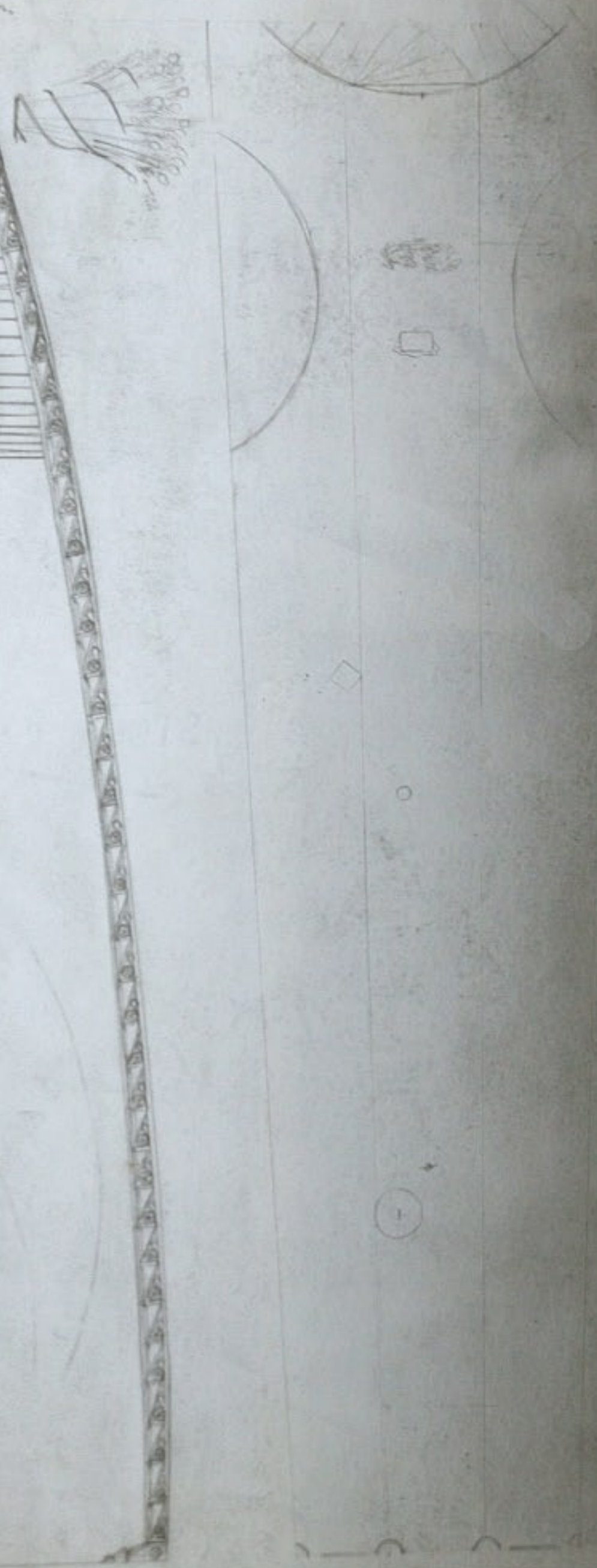
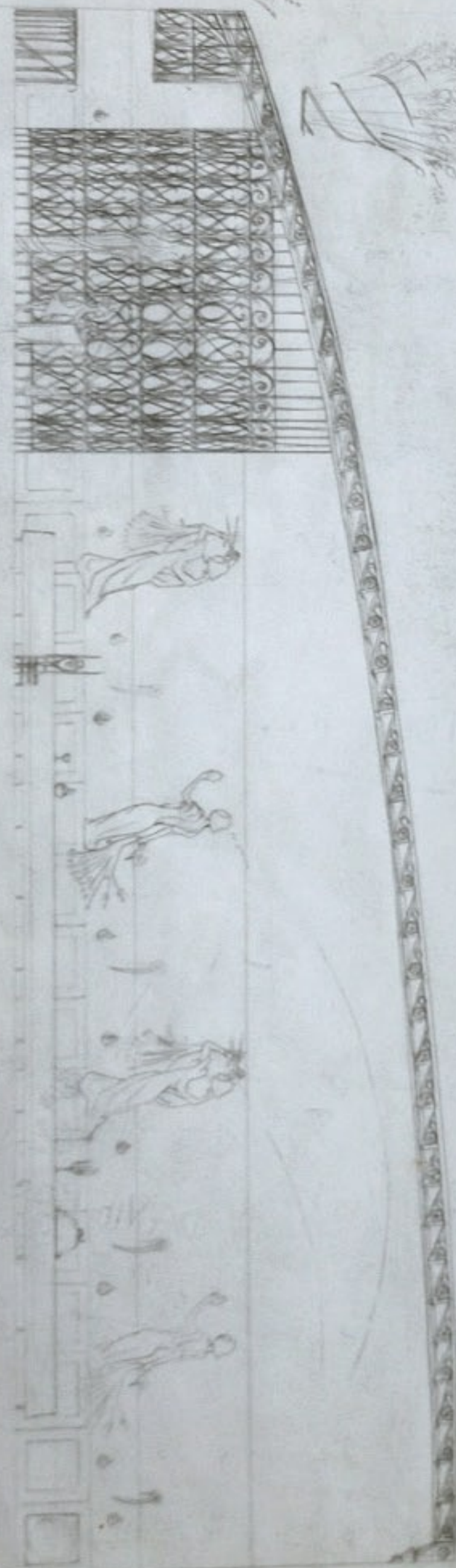



HOW CAN I SMILE WITH THE FACE OF A DEVIL?
A METAPHOR IS A CRUELTY

12/5/00
19
11

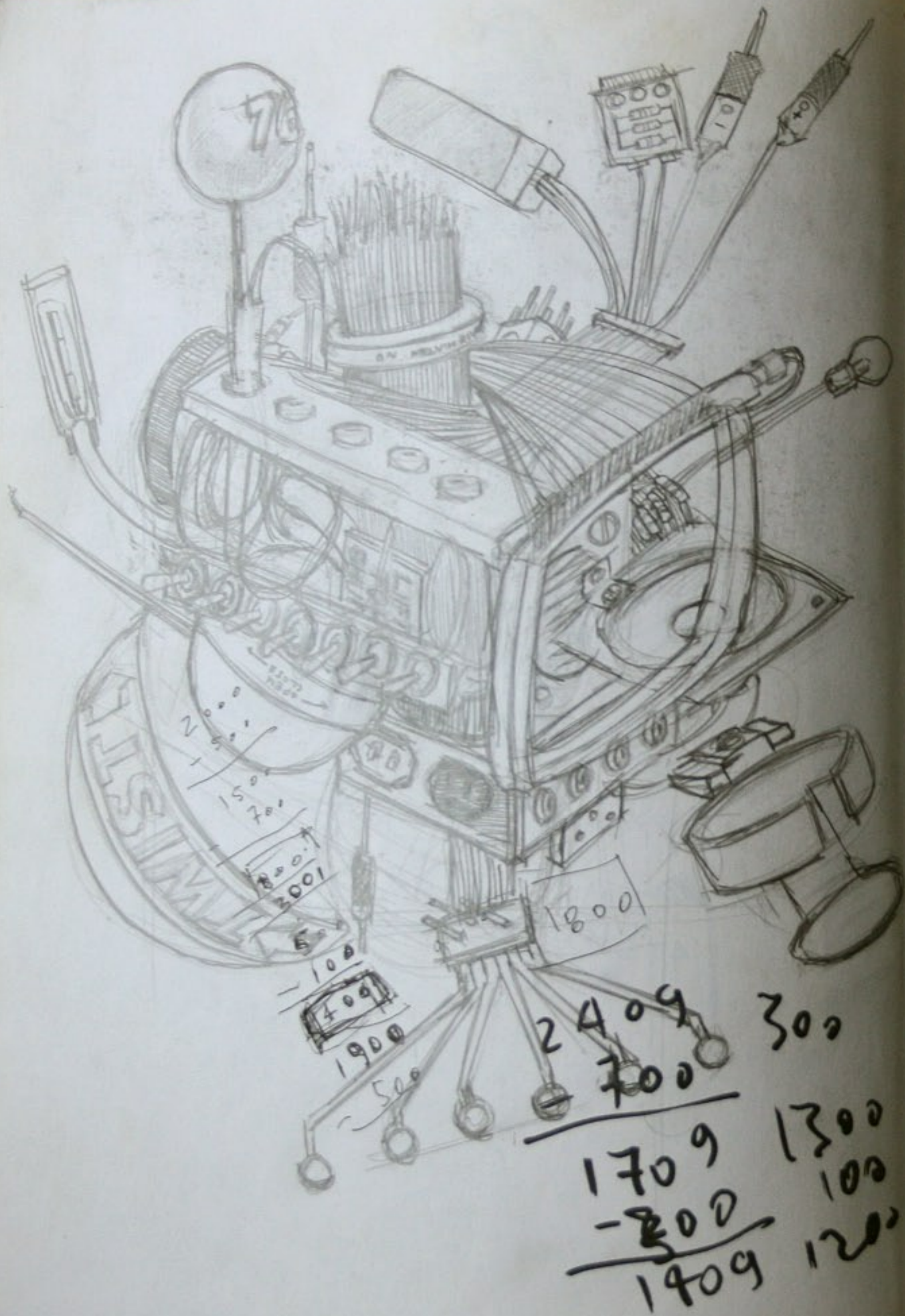

CALL ~~LOVE~~ ABOUT
 X OPTION DEL

VIRATEL
 TIM BURZONA



Cedar 1 1/2 X 42 pcs
SHIMS
Cunas / de cèdre

7 78362 14500 3



BARDOBEC INC

www.bardobec.com



51, rang Ste-Marie, St-Just-de-Bretenières, Qué. • 418 244-3612



State Fair



자
L

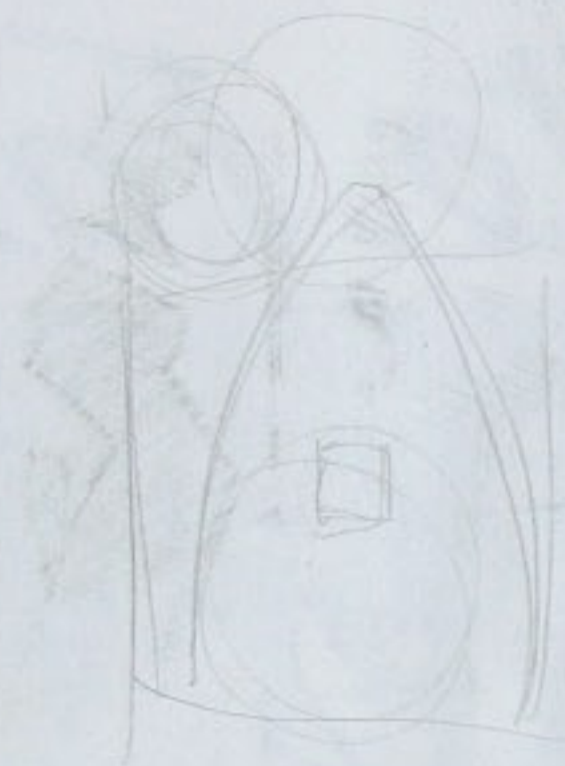

HIGH ON THE HOG
HOGWILD
HOG HEAVEN
MAKING BACON
BRINGING HOME
THE BACON



BEFORE IT SPOILS

ENTAILING

WRITE OUTLINE



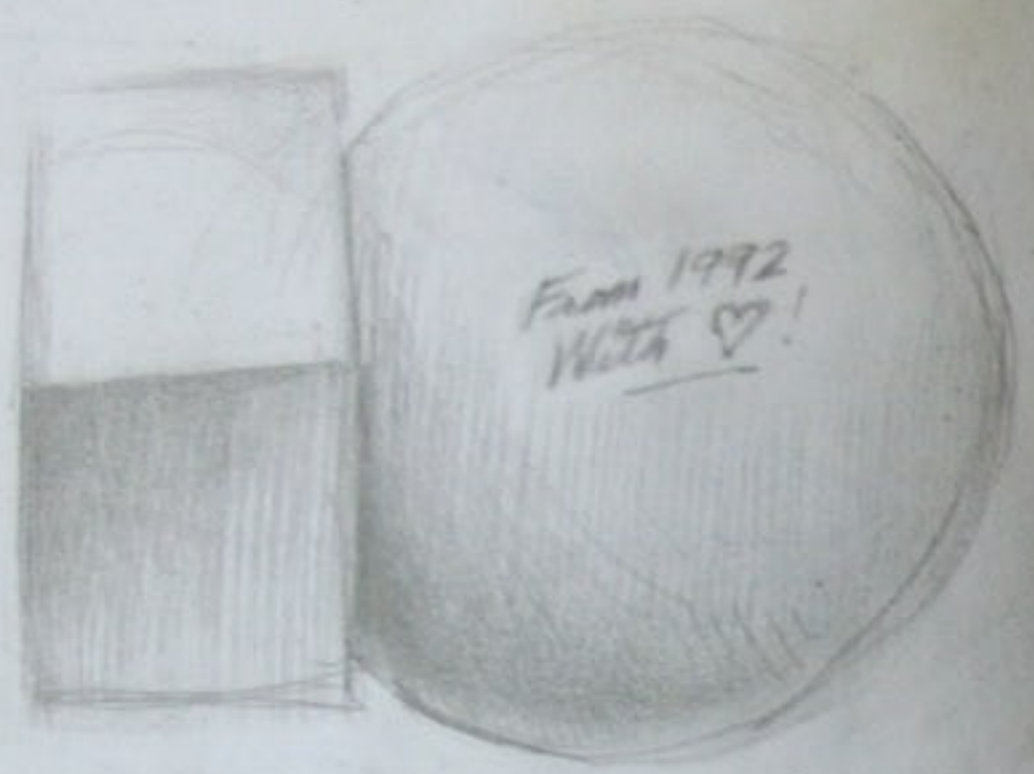

WILLIE
~~574 2807~~
574 9284
URETCHEDNESS
&
BEAUTY

COUSIN MEL
JANICE
&
JON
PETERSON

305-895-3508

SILHOUETTE AGAINST
THE SKY AND THANTON
IN THE NIGHT CALLING
FROM BEFORE MY TIME
I'M HUMBLED BY MY
LITTLE PART. MOVING
TO THE CENTER STAGE
I SHOUT OUT MY LINE
KNOWING EVERYTHING WILL
TURN OUT FINE



0512128

THE TOYS WERE ALL SILENT



THE PINK ONES ARE TASTIEST.



CREEP



THE TOYS WERE ALL SILENT

96668

S(S)

→ 133(R) →

JEFFER

8:30

CHECK W/ RECHER
CHECK W/ SALARY
CHECK W/ SUPER & SOUND

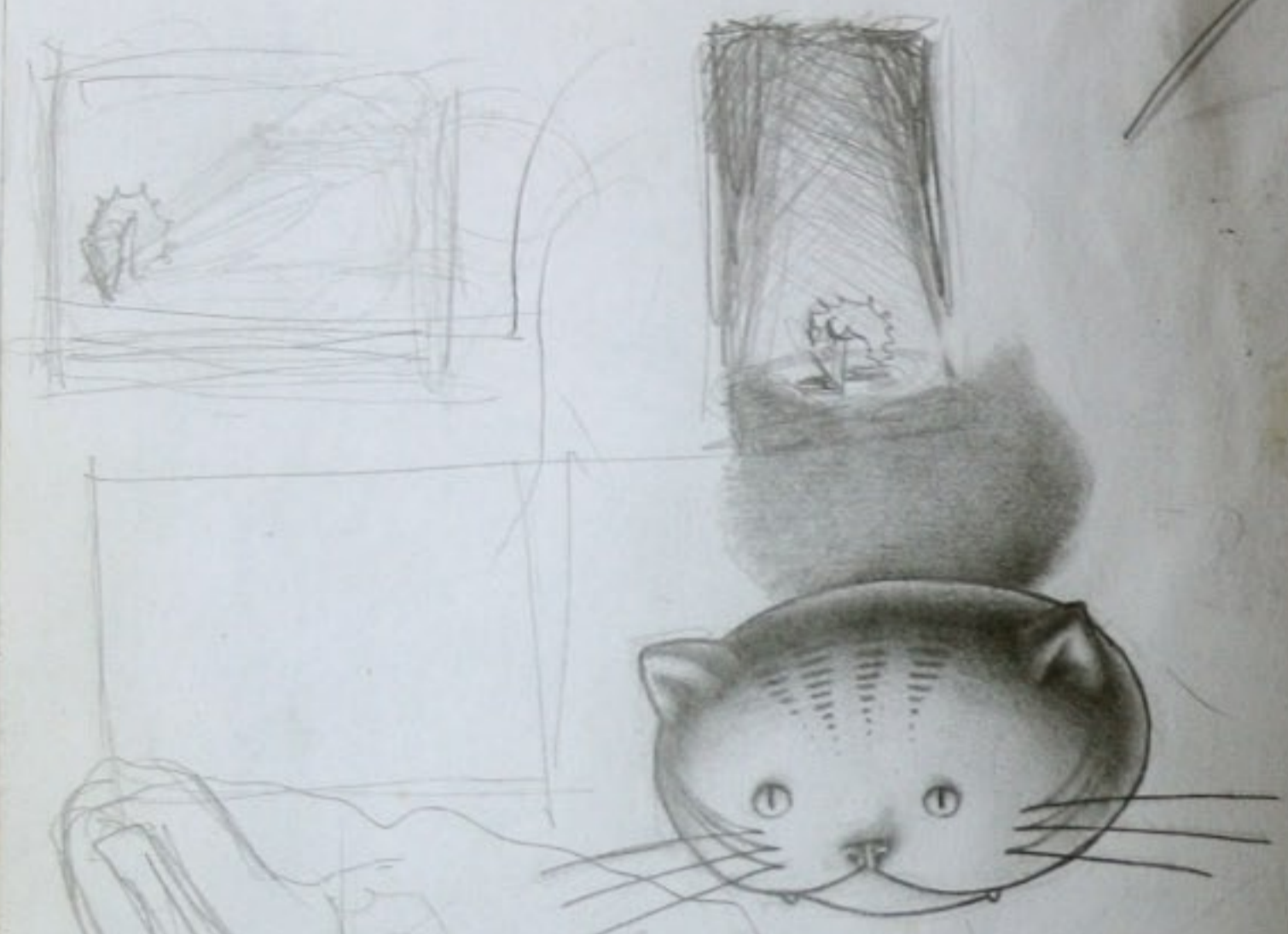

YOU'LL BE
SORRY YOU
RIDICULOUS
ME.

~~WHEN ELEPHANTS
SHEW THEIR ROSS~~



PINATA

COMPUTER

IF SOMEBODY TELLS YOU THAT THEY LOVE U
DONT BELIEVE IT IF THEY HOLD A GUN TO YOU

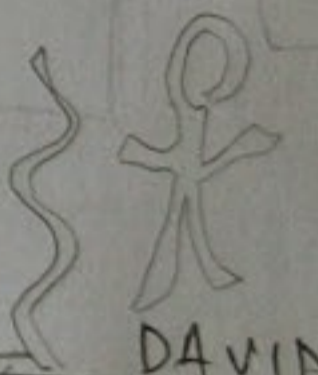

DAVID

818 707 1176



FRIDAY

JAY
KATO

IT WAS
OVER.



MICHAEL BOLTON
IS TENDER
(BUT I WOULD NOT
FEED HIM TO BOO.)

DO TE
ITSY
BITSY
SPIDEY



WHERE IS THE FRONT OF
THE LENS?
DOES IT MATTER?

SCARLET 1875

MEN ARE LIKE
INDECISIVE
TRANSVESTITES

SEND
PAPER
SAMPLES
TO
ECUADOR

BEARDSLEY
HAS NO
EFFECT ON ME
BUT NAUSEA

CONSTANTS
CHARACTERS



(GRIP? TIGHTLY)
LOUD
SOFT

~~SHARP~~
~~SMOOTH~~

~~QUICK~~
~~SLOW~~

UP
DOWN ← WHAT

SATURATION & DEPTH
BRIGHTNESS & DEPTH

← HOW

DIZZA

THE USEFUL

(EVERYTHING BUT
AUBREY BEARDSLEY)

BEARDSLEY
WAS A
GONER

THE GREAT CHASM OF
STYLE &
CONTENT



THE
USELESS

(AUBREY BEARDSLEY)

FANTASIA KEPT TO THE MUSIC, SIMPLY INTERPRETING IT, FALLING
SHORT. THE ONLY LIMITS IT PUSHED WERE CUTESIMING OR
CARTOONIZING (WHICH CORNERED IT, STYLISTICALLY). ADDING TO
IT CANNOT SIMPLY BE IN THE CONTENT OF AN EXACT
METAPHOR. THE NATURE OF EFFECTIVE STORYTELLING
CALLS FOR EXPOUNDING & EDITING, FOR THE PUSH & PULL
OF HYPERBOLE VS. SMOOTHING (FOR THE COLORIZATION
& DESATURATION OF DETAILS FOR THE SAKE OF EMPATHY).
AGGRESSIVE & ZEALOUS INTERPRETATION OF THE SOUNDTRACK
IS DISPLAYING WHAT WOULD NEVER BE AUDIBLE IN
THE LAYER OF THE COMPOSITION TO BE DULLED, DISTRACTED
FROM, AND TO BE BROUGHT CLOSER TO ORNAMENT.

It is faster
It is faster

26
10
11

SAT 12
3
8

TUESDAY
15
17
18
SAT 19
20
27

straight
21
22
23
24
25

OH SHIT.
I DREAMED I MADE
A DOCUMENTARY



4-8
WEDNESDAY

BILLY
VIVIAN
ELLEN

6-11
TUESDAY

JEREMY
BRANDON
JASON

7-12
MONDAY

MIKE
JC
JULIE

8-
THURSDAY

MATT
FRED
KURNIA



NOD

I CAN WRITE IN A straight line but my handwriting

I CAN WRITE ~~ASTER~~

VIVA ~~ASTER~~



- GUMDROPS
- LOLIPOPS
- RIBBON CANDY

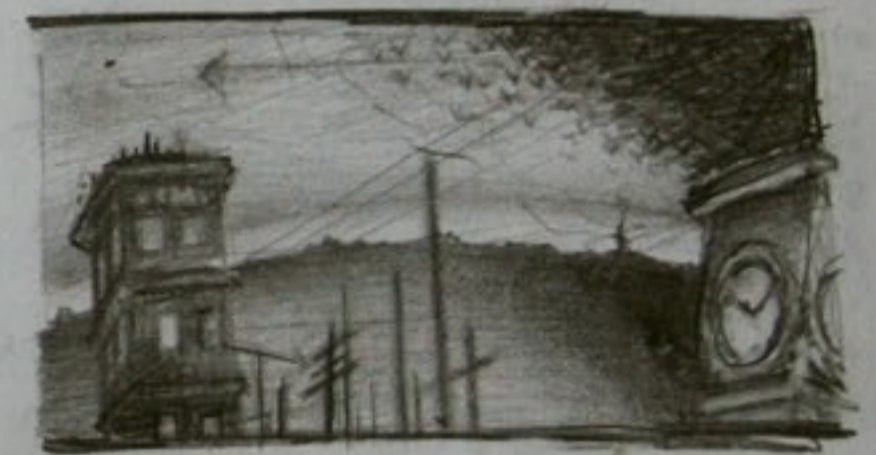

BIRDS ARE FUNNY

PRETTY BABY

WHAT EE!

PRETTY
BABY

MY DISTURBED WIFE

VE RONIGA
PRETTY!
MY
MI CIELO BONITA



Vertical text, possibly a title or reference, written in a cursive or handwritten style.

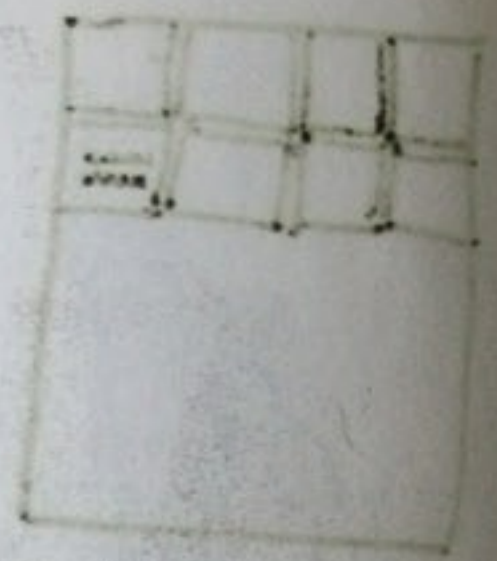
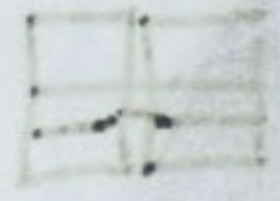

THE DENTAL ASSOCIATION
SET A TRAP.

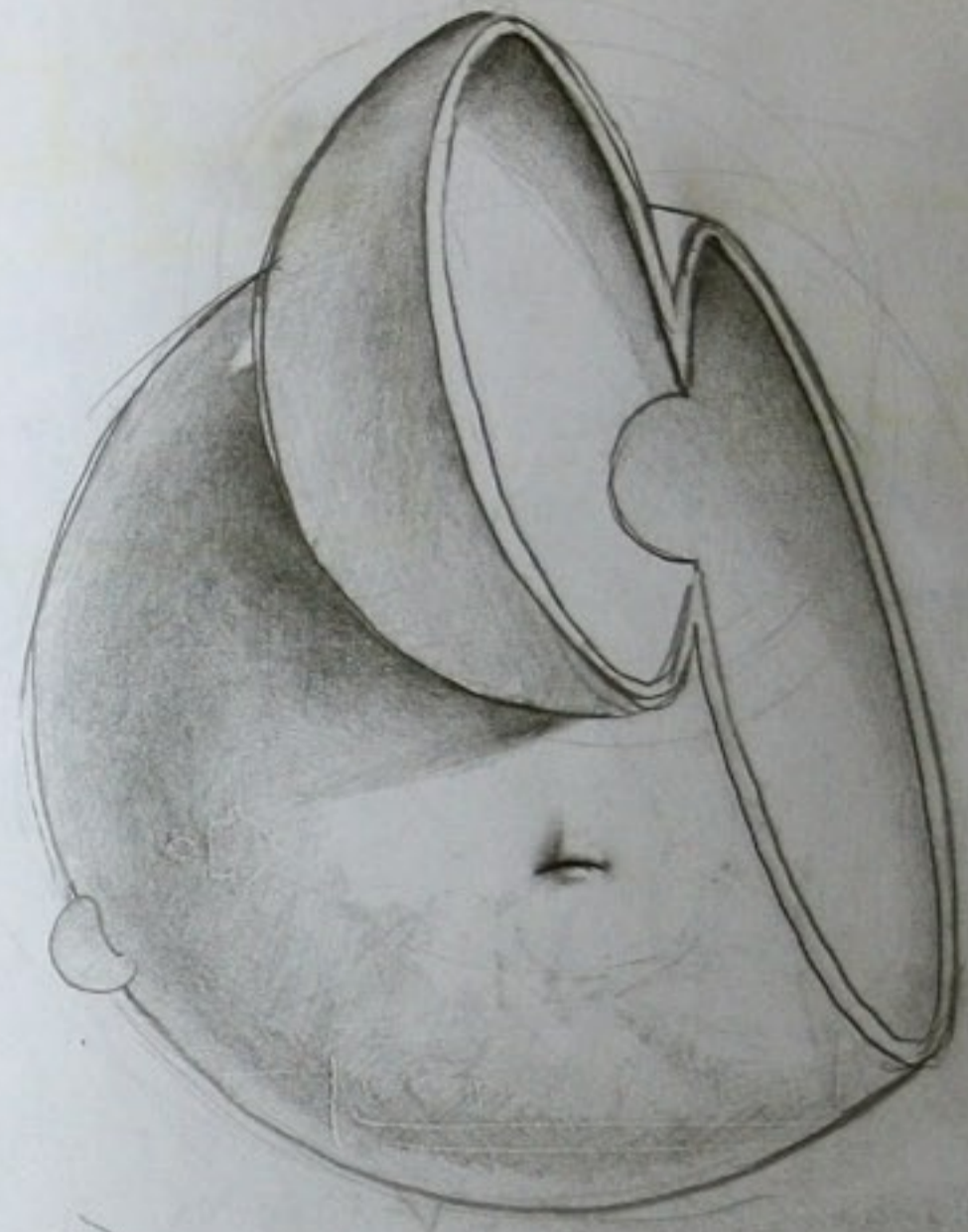

(WELL-DESIGNED)

DUMB INTROSPECTIVE OBJECT

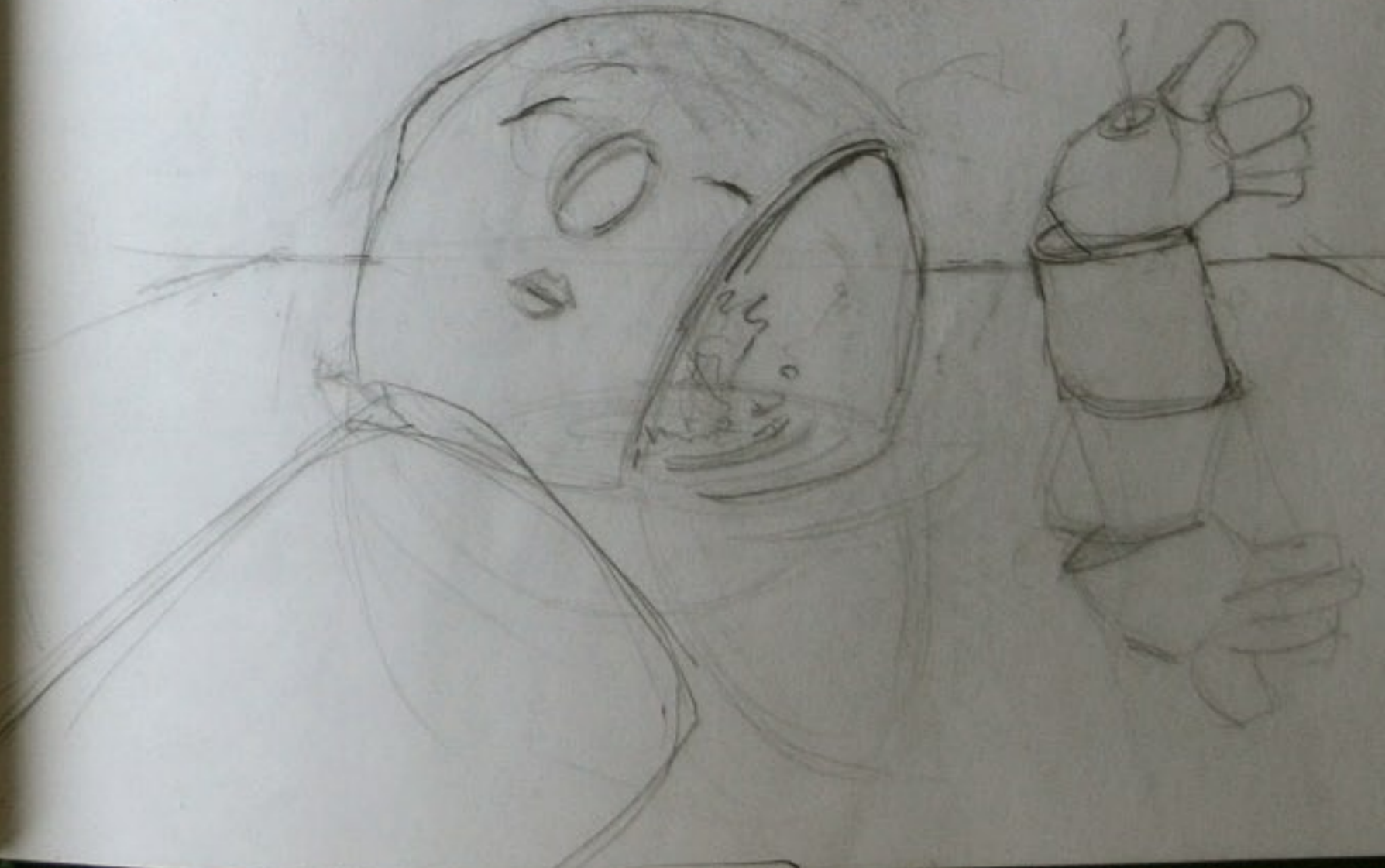

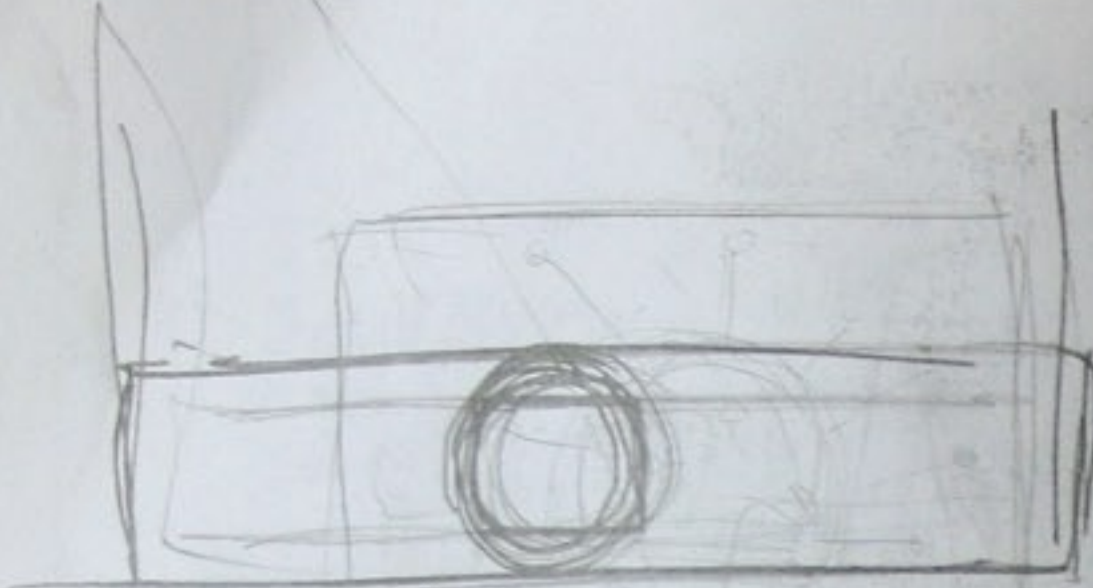

MISSION
 CLOSET
 A MAIN
 B DRESSOMATIC
 C



H

3413 PACIFIC AVE
 91505

oo gerhed

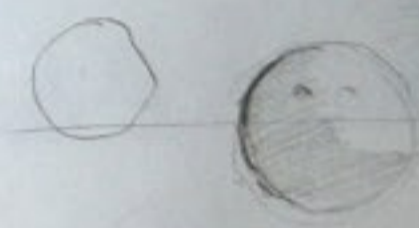

- GANG ACTIVITY
- SECURITY METERS
- CHECK APPLIANCES
- ~~REST~~ PEST CONTROL

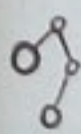

- GARAGE
- MAIL BOX
- CHECK WASHER/DRYER
- TRIM & MOW LAWN & HEDGES
- LOCKS
- GAS?
- ? UTILITIES



MR
HULOT'S
HOLIDAY

WASHING
MACHINE
PARTS

JARQUE
TATI
M-WAMI



FABRIC SLIDER

GREEN



INFINITI MOTORS.COM - NICE STYLE
ENERGIZER.COM

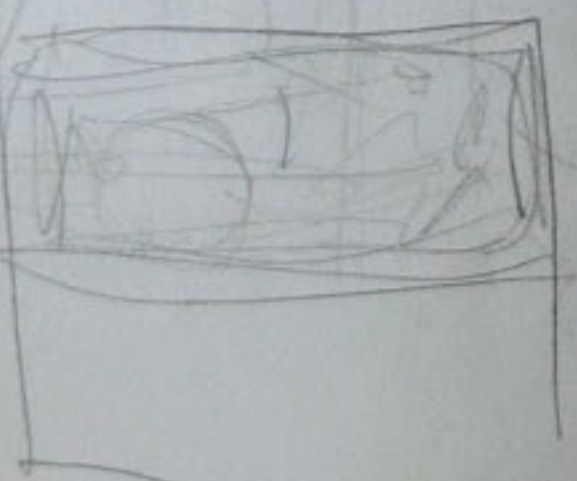

NEEDS DRY
FANTASTIC
SCALE OF
COMMERCIALS
WITH J. PRYLE

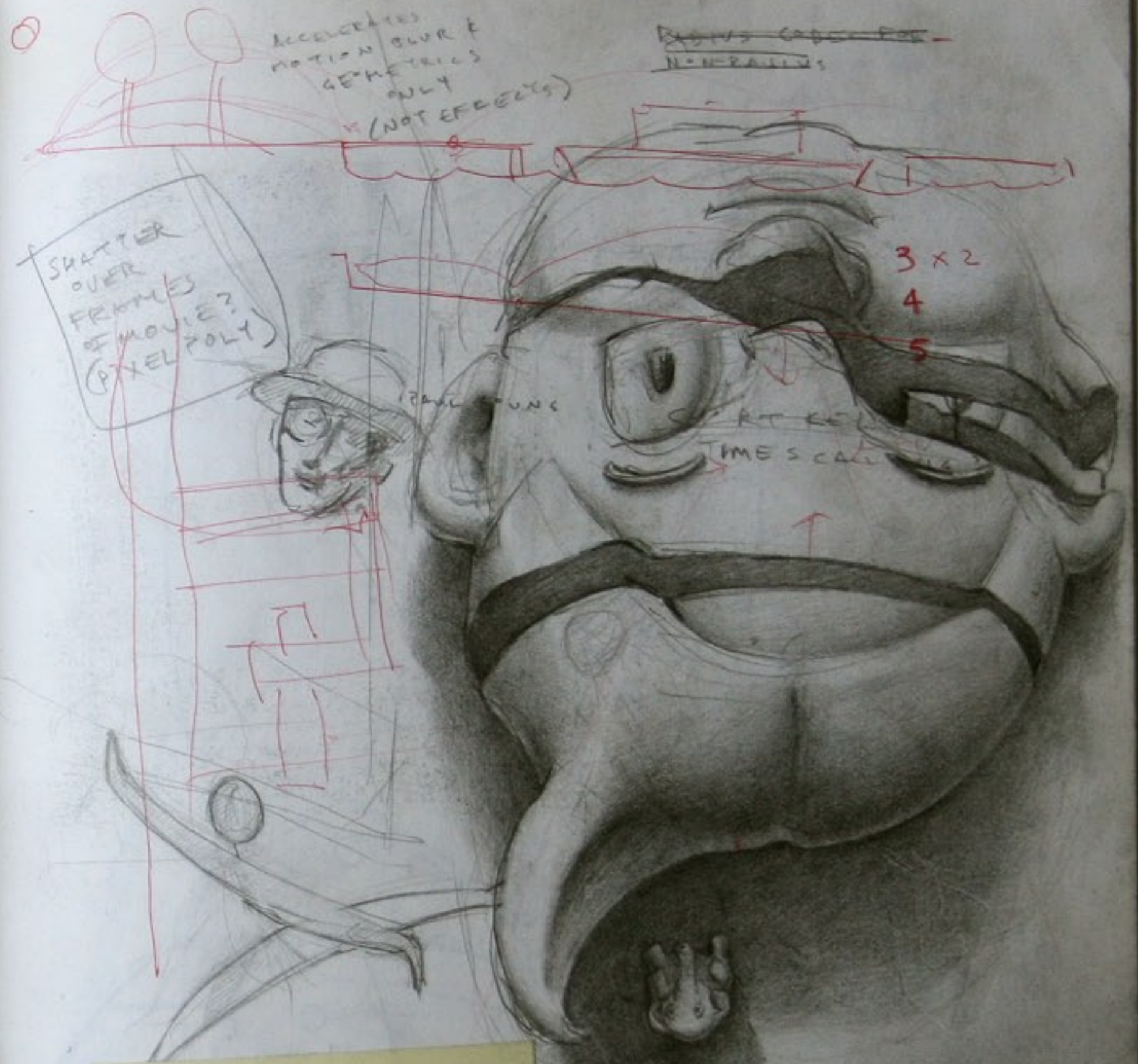

WWW.PRIMUS.COM/STAFF/
PAULP/USELESS.HTML

S'7

IMAGINE THE MOST INAPPROPRIATE ENVIRONMENT TO DIE IN WHERE EVERYONE ELSE IS COMFORTABLE

HOSPITAL

WASHED LIGHTING (COLOR OVERLOAD)

(EVEN OXYGEN TANKS ARE PASTEL BLUE)

COLORS PUMPED

INAPPROPRIATE GIFTS & DEMANDS

COLORS FROM: BIGGEST GIFT BASKET OF FRUIT

HOSPITAL GREEN WALLS

PAINTING (OPPOSITE) OF LUIGI OF

CLOWN MADE OUT OF VEGETABLES & FRUITS

* NEED WIDER SHOT FOR PAINTING



COLORFUL LOCOMOTIVE PAJAMAS



DISGUSTINGLY NEATLY ARRANGED FRUIT BASKET WITH KRINKLY CELOPHANE WRAPPING

CROSS PROCESS

3 WALLED



- POSTERS HANGING ON WALLS (COMPUTER PRINTOUTS)
- GET AS MANY SHOES AS POSSIBLE & LINE WALLS ON SHELVES (HANG FROM STRINGS) (POSSIBLY BUILD ON OPENING SHOT TO REVEAL MORE & MORE SHOES GRADUALLY?)

CLAUSTROPHOBIC

I WOULD LIKE TO COMP IN A GIANT FLOCK OF BIRDS (NOT OMINOUS, BUT JUST SOMETHING TO ENCOURAGE EXCITEMENT OF "CUP O' TEA")



2

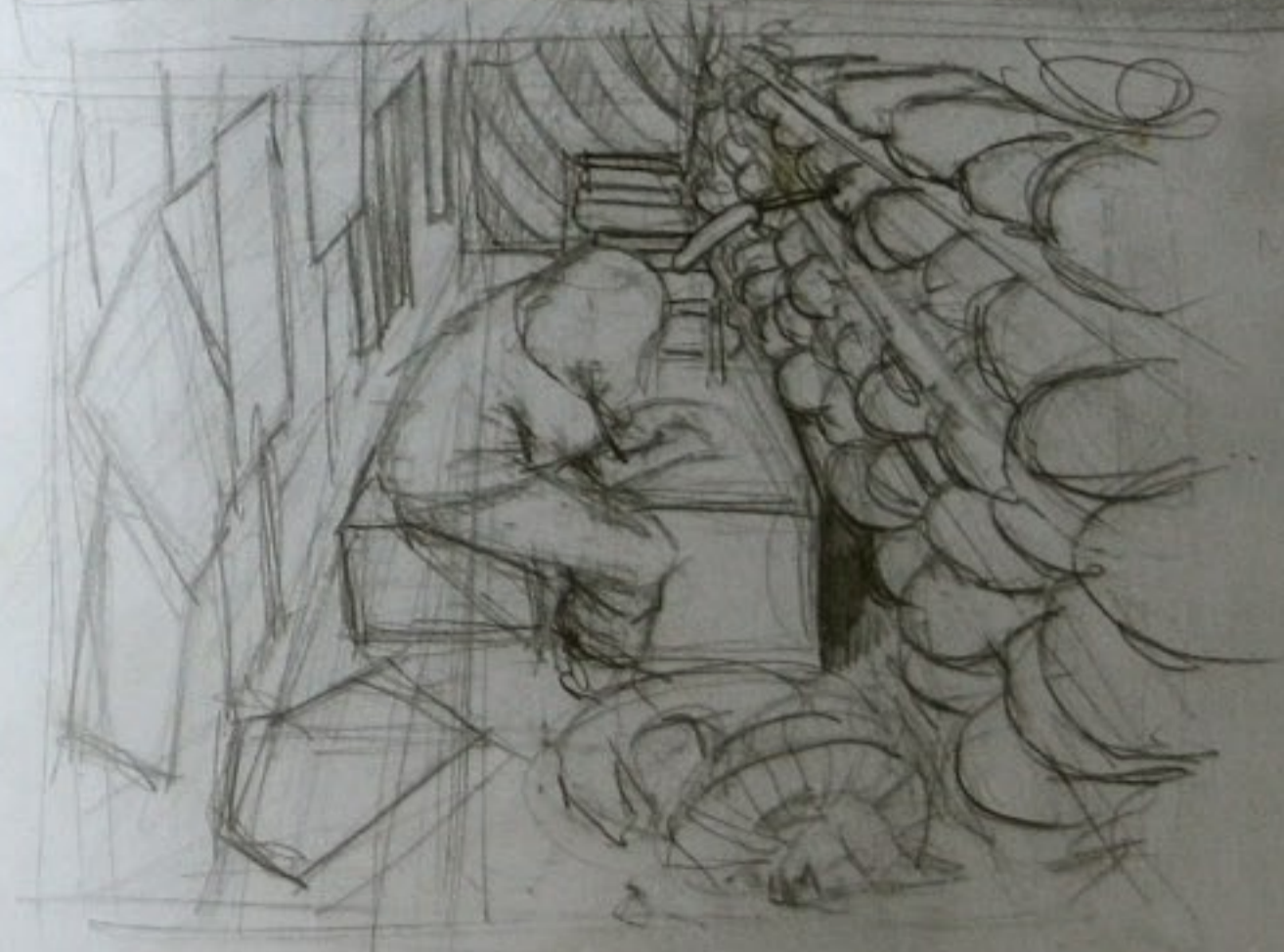

314
5614



RED | YELLOW | WHITE

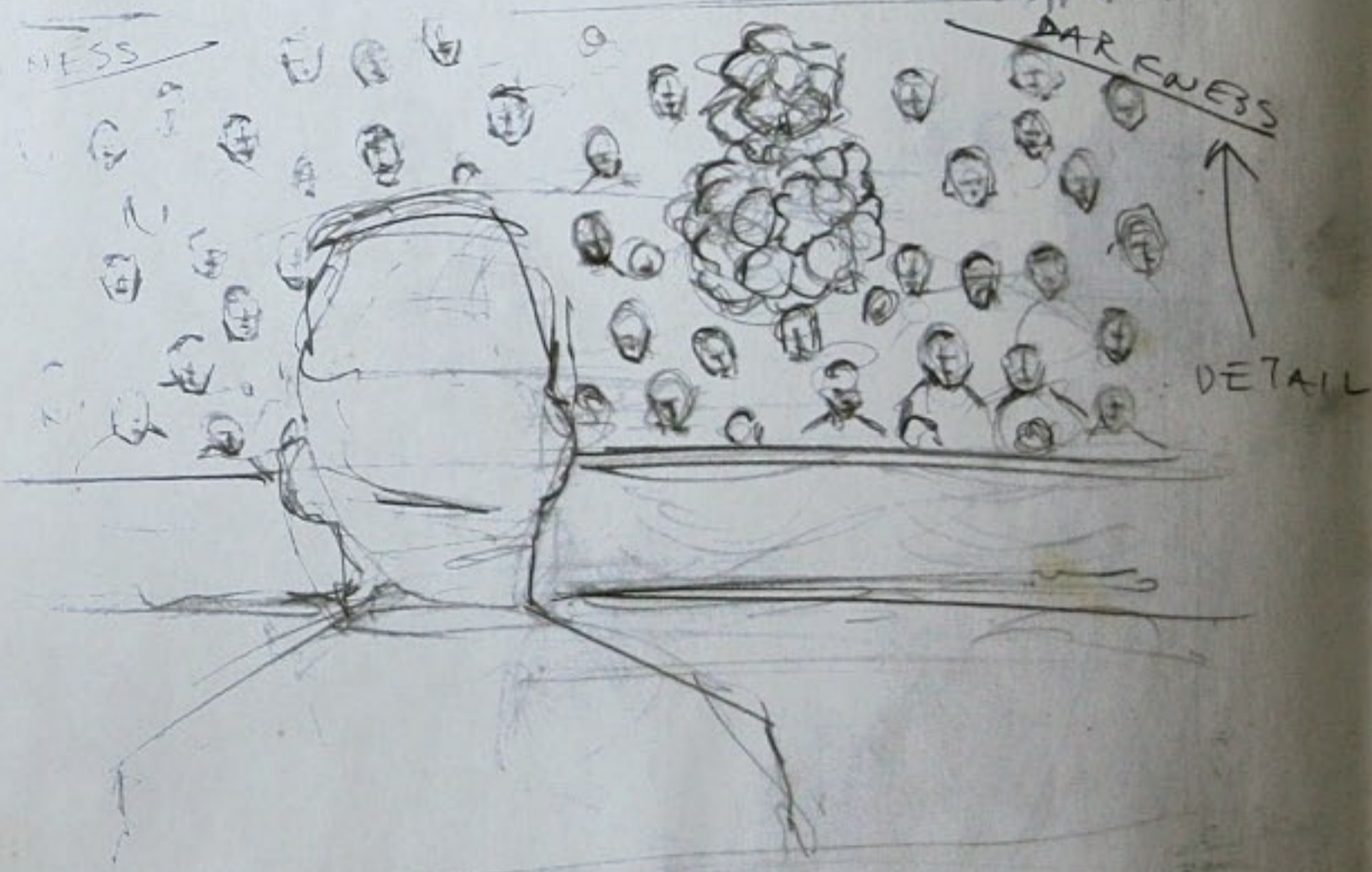
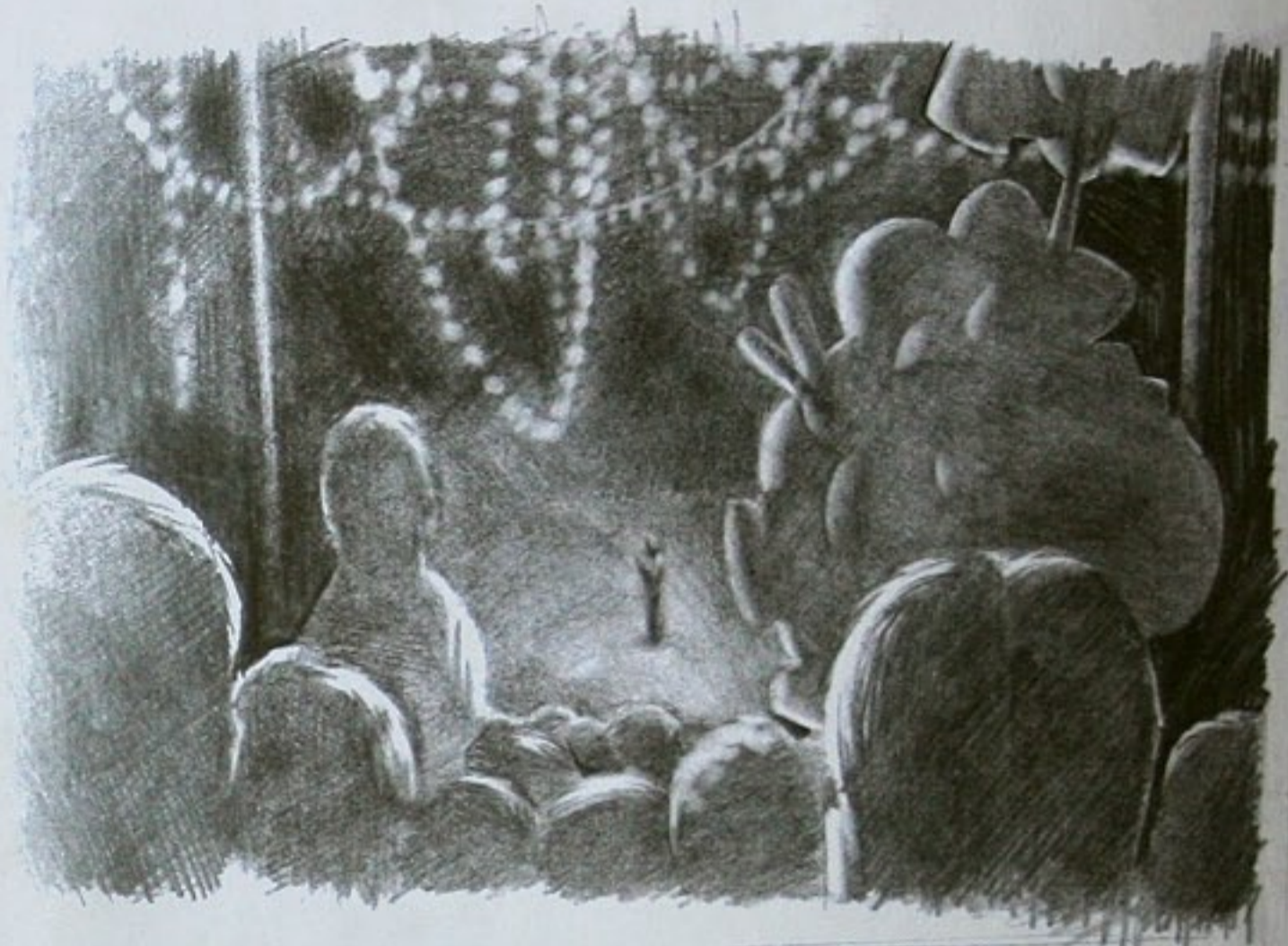

ANTONIO
213 963 0722

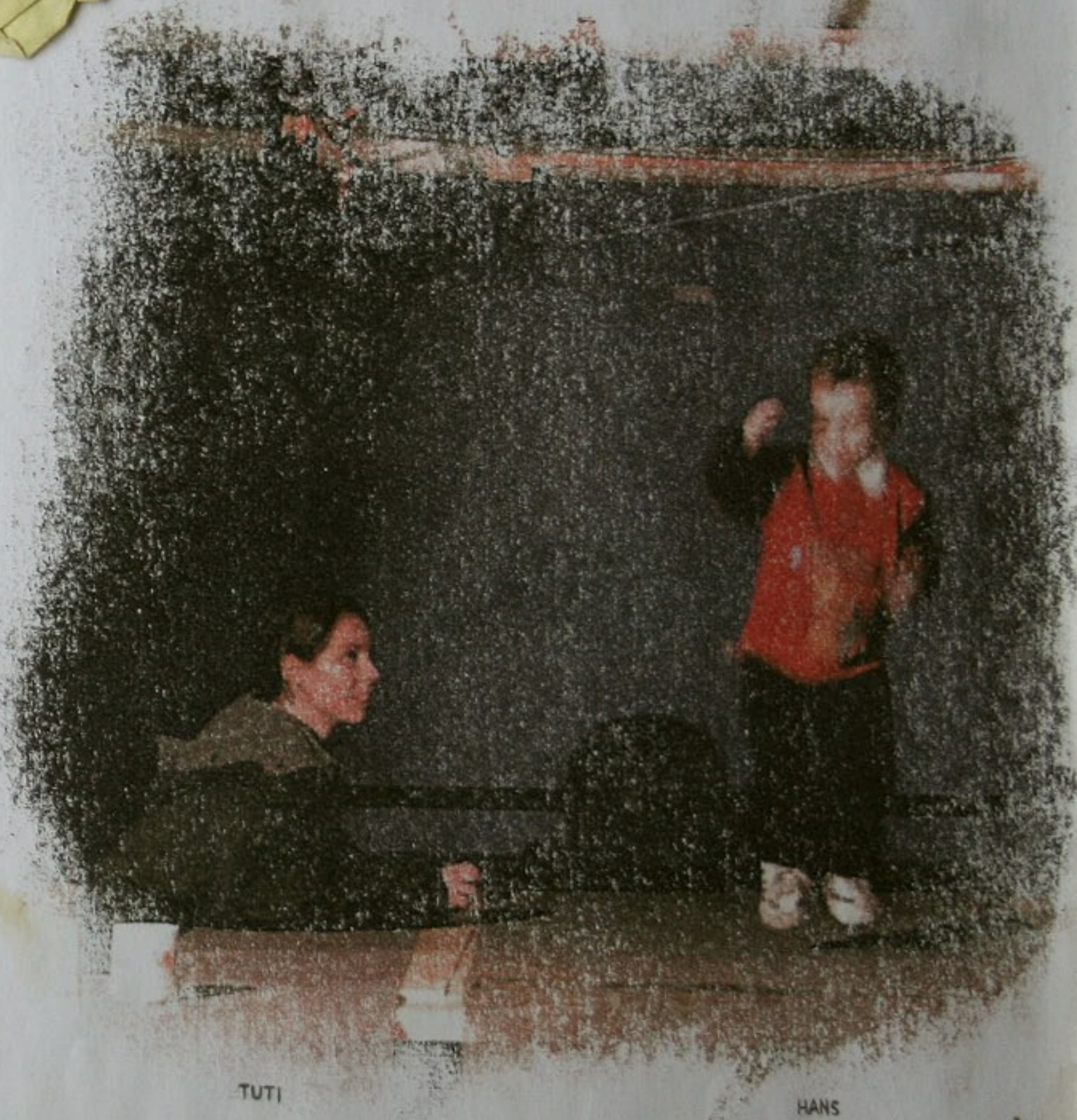

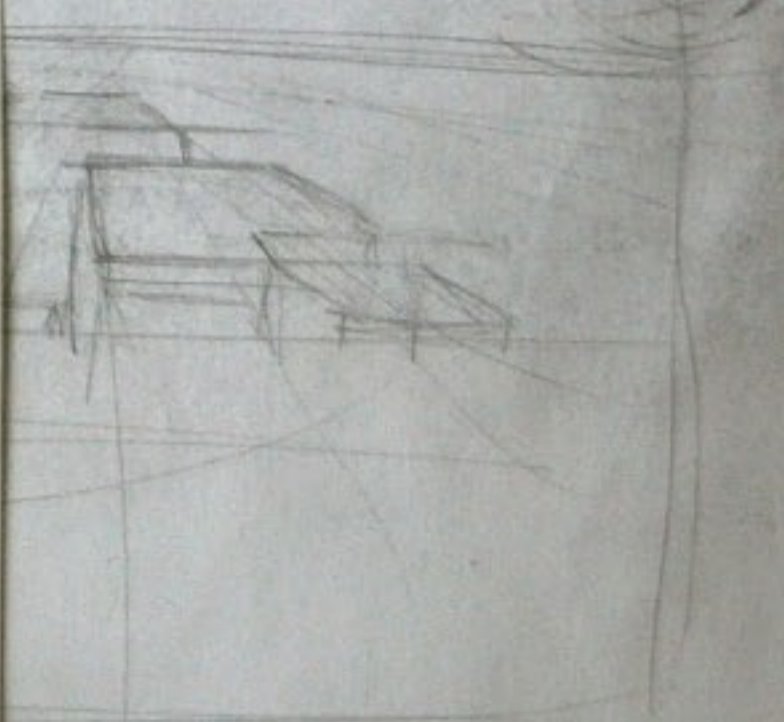

CALL L-KI ABOUT JELLY



4.99 to 24.99 exceptional price
Pure & Natural French-milled soaps.
Beautiful gift boxes in several colors and fragrances. Cosmetics Dept.



FRANKENBERG

ARMATURE WIRE 3/4 1/8 1/16
EPOXY PUTTY
SCULPEE 2

FIG 8FOXY
1 800 HOT HOGS



DREAMHOST.COM

KIMBERLY
800 965 7093
440 FAX 269 781 2
444 ELMINGTON AVE #114
37025

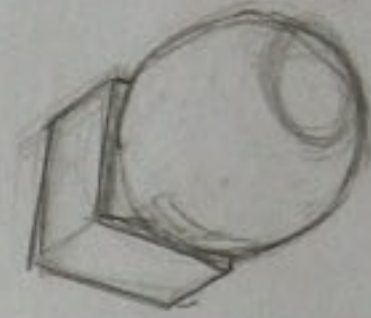

901 367 0911

SEE YOU LATER WIDE!

DAN@WORK
310 311 2800
X2303

"ARE THOSE ANIMALS
REAL?"



192.246.40.37:

279603

JAMES
3611849

WITH UNDERSTOOD
PEOPLE...

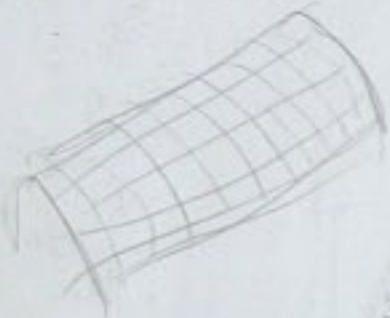

HOW SHOULD WE CONVINC
PHILIP WAS AN AMBITIOUS
BY SHOWING HIS WORK

THE AUDIENCE THAT
ARCHITECT EXCEPT

IF WE SHOW THE MODEL, WE NEED
TO SHOW AT LEAST A MATTE OF
THE COMPLETED APARTMENT
BUILDING.

CAMERA MOVES THROUGH
MINIATURE & SIMILAR
MOVES THROUGH CA
OR MATTE MINIATURE
"REAL" ARCHITECTURE.



- ① "TO BE A PART OF SOMETHING GREATER THAN OURSELVES"
DID HE BELIEVE IN GOD? HE DID HALF-HEARTEDLY &
WAS ALSO REBELLIOUS (ARCHITECTURE EVEN QUESTIONED
RELIGIOUS MEANS & VOCABULARY). MORE OF A
"WILL" WARSHIP IN HIS OWN WAY? ATTITUDE GIVES
BIRTH TO PANTHEISM & EVENTUALLY DEISM; ARCHITECTURE
BREAKS UP A CLOCK WINDING DOWN.
- ② BELIEVE IN COMMON NATURE OF ARCHITECTURE & ENCOURAGED
ALL AGES TO APPRECIATE DETAILS, NATURE, LIGHT & COMMUNITY.

NEW ORLEANS
HYATT?

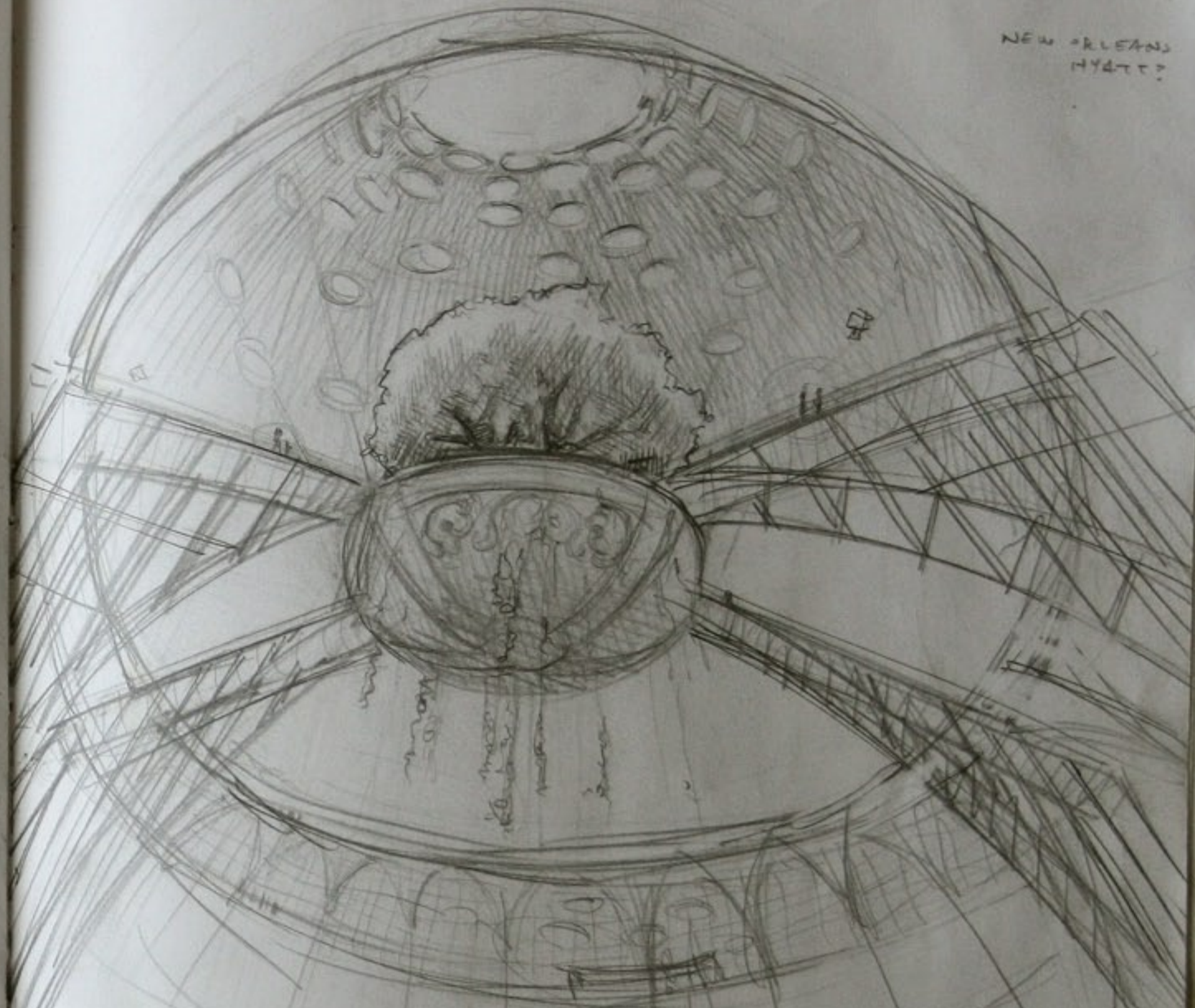

- ③ AGENDA IS TO ENCOURAGE
THINKING ABOUT THE
UNSEEN MYSTERY ABOVE
& BELOW IN HIS OWN
UNIVERSALIST TERMS.
TO MUCH FREE THOUGHT
& UNRESTRAINED
IDEAS & EXPERIMENTING
- ④ WHAT MOTIVATED PHILIP TO BUILD & DESIGN?
- ⑤ WHAT IS HIS AGENDA? IS THIS HIS DOWNFALL OR IS IT JUST
AGNES' ACCIDENT?
- ⑥ WHO DOESN'T HE LIKE?
- ⑦ IS HE ELITIST?
- ⑧ IS IT A BIG HOTEL?
- ⑨ DOES HE EFFECT JUST THE ARCHITECTURE WORLD OR
THE OUTSIDE WORLD AS WELL?
- ⑩ DID HE COMPLETE HIS VISION?
- ⑪ PRO-OR ANTI-MACHINE ERA

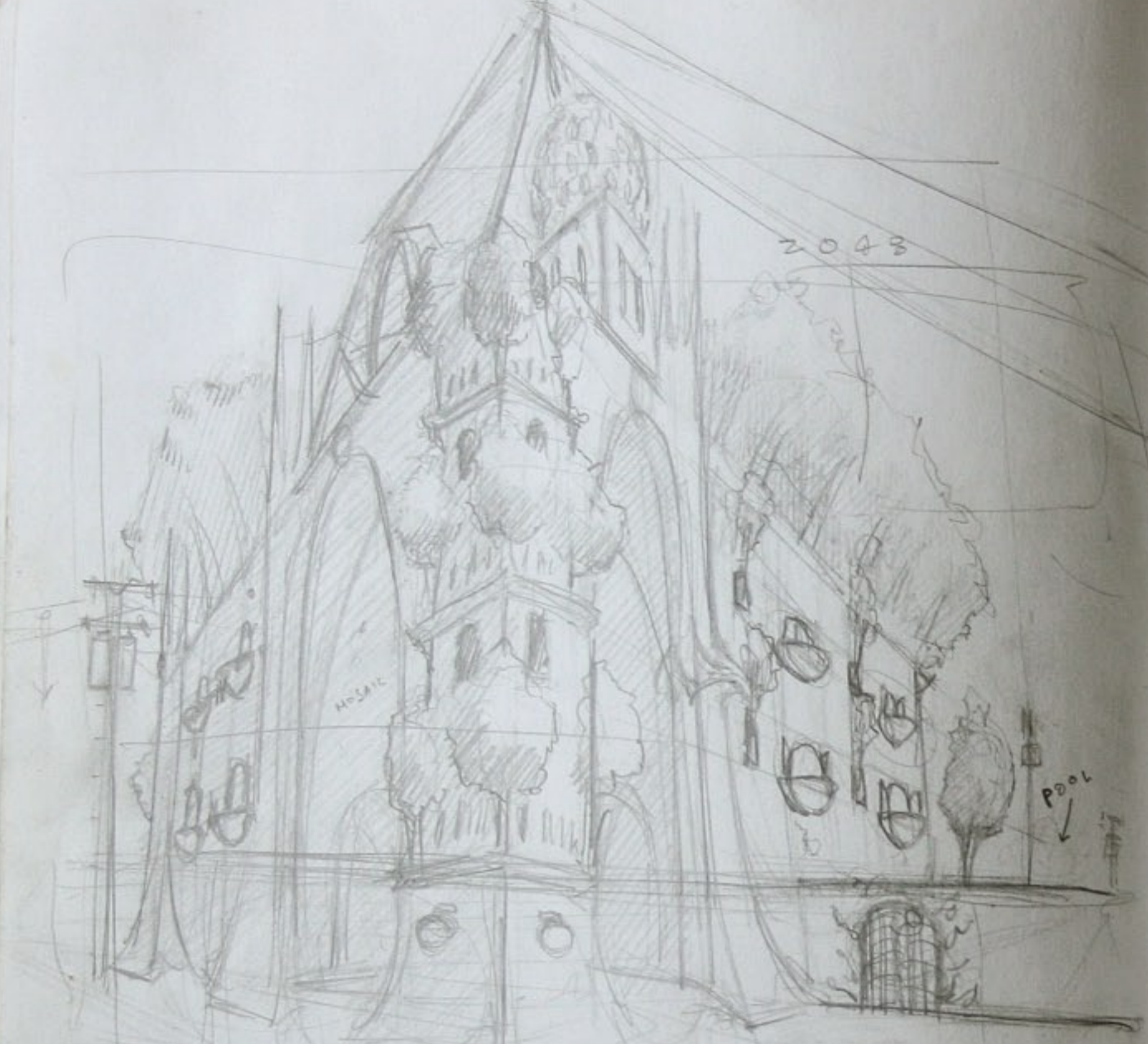

2048

HOSPITAL

POOL

Transition to Round

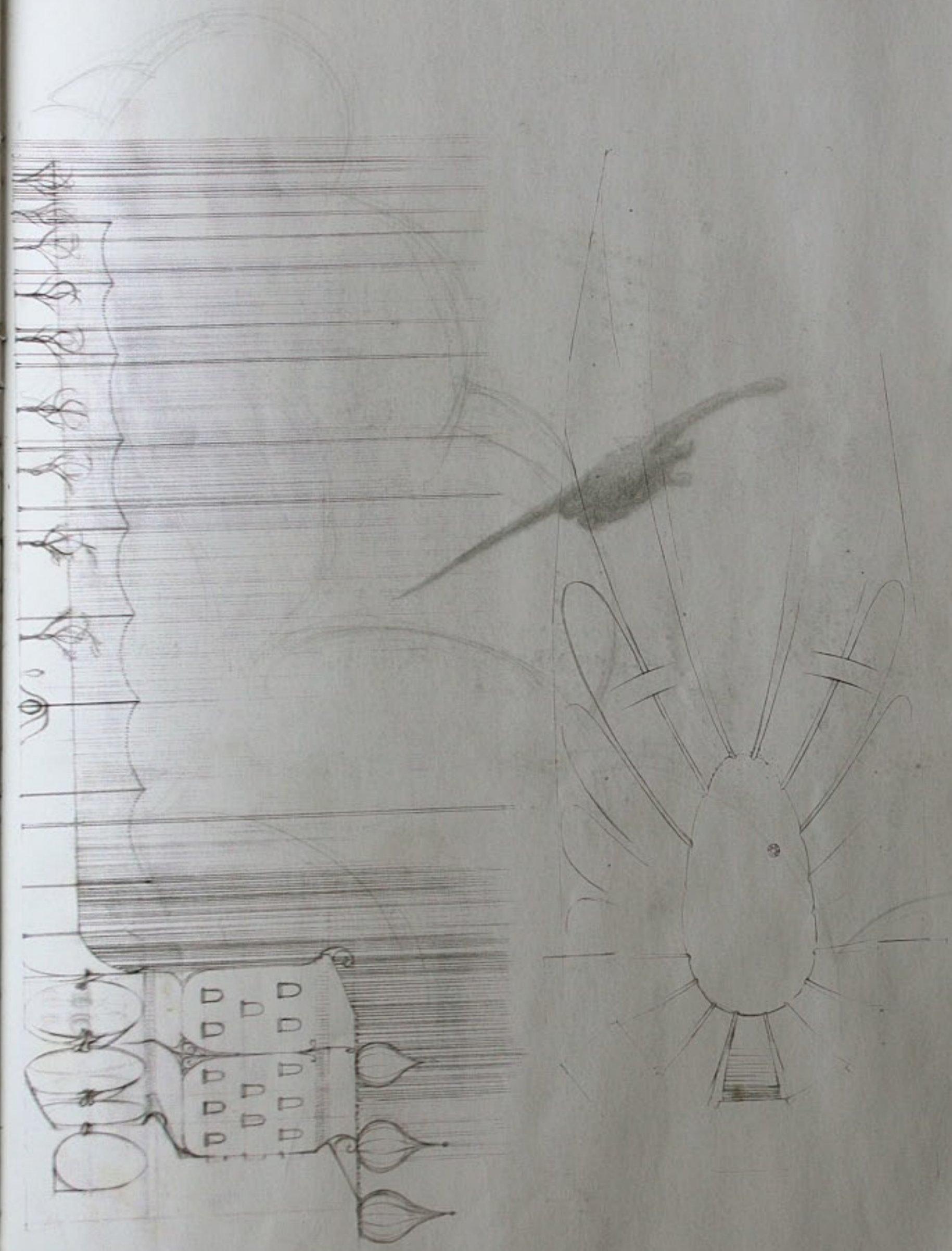
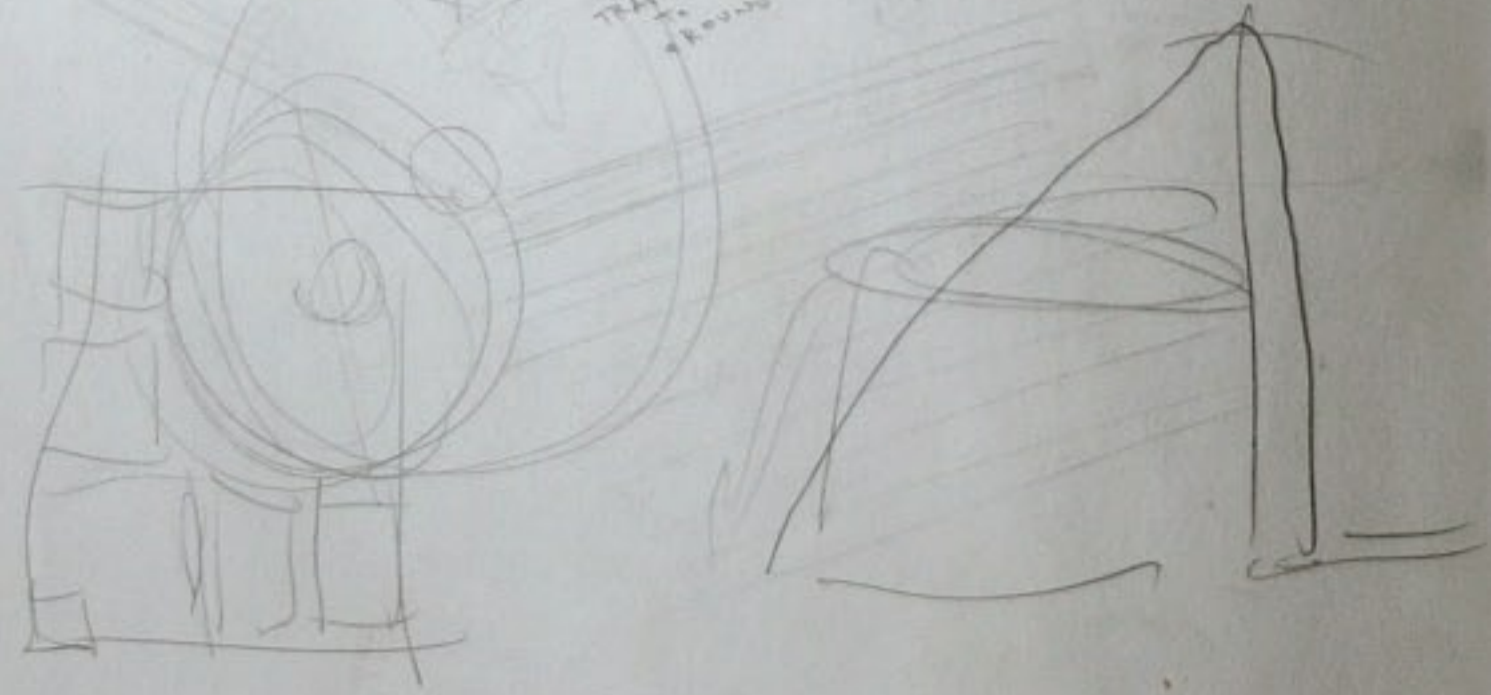

TEXTURE STAMP

KENDRICK
300 8200
665 3132

ALICE
WILL BE
THERE TIL
5:30

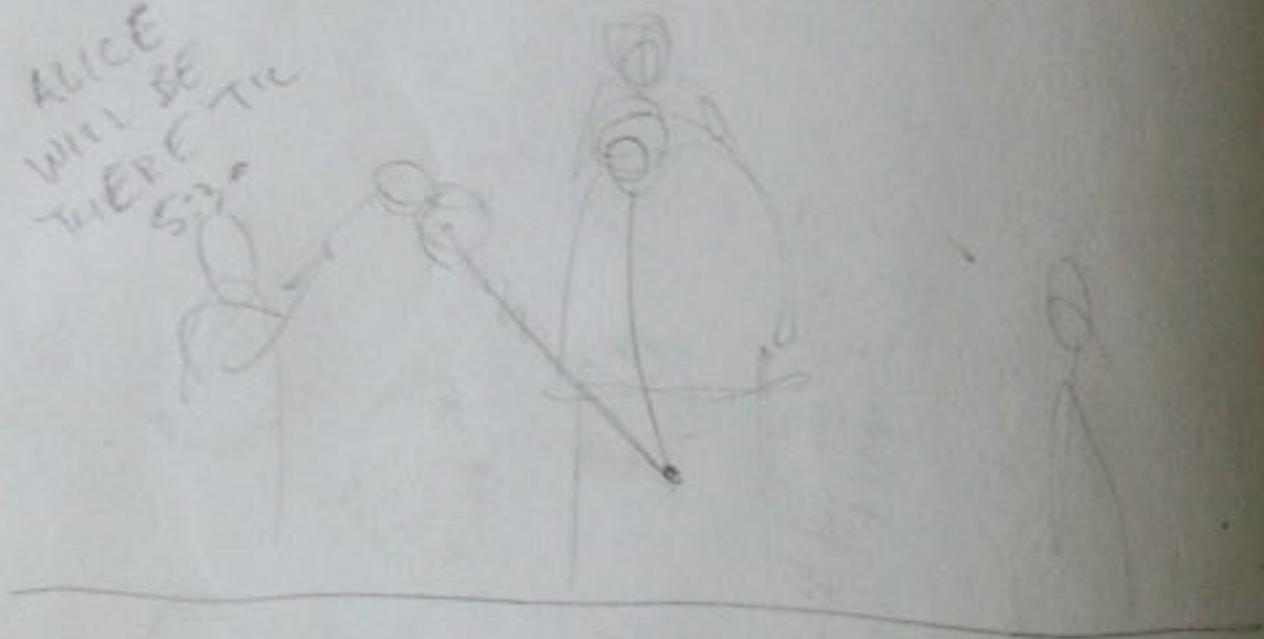

0000 890 5128

MICHAEL WILSON
673 2272

DAVE
832 2905

JAMES
818 361 1849

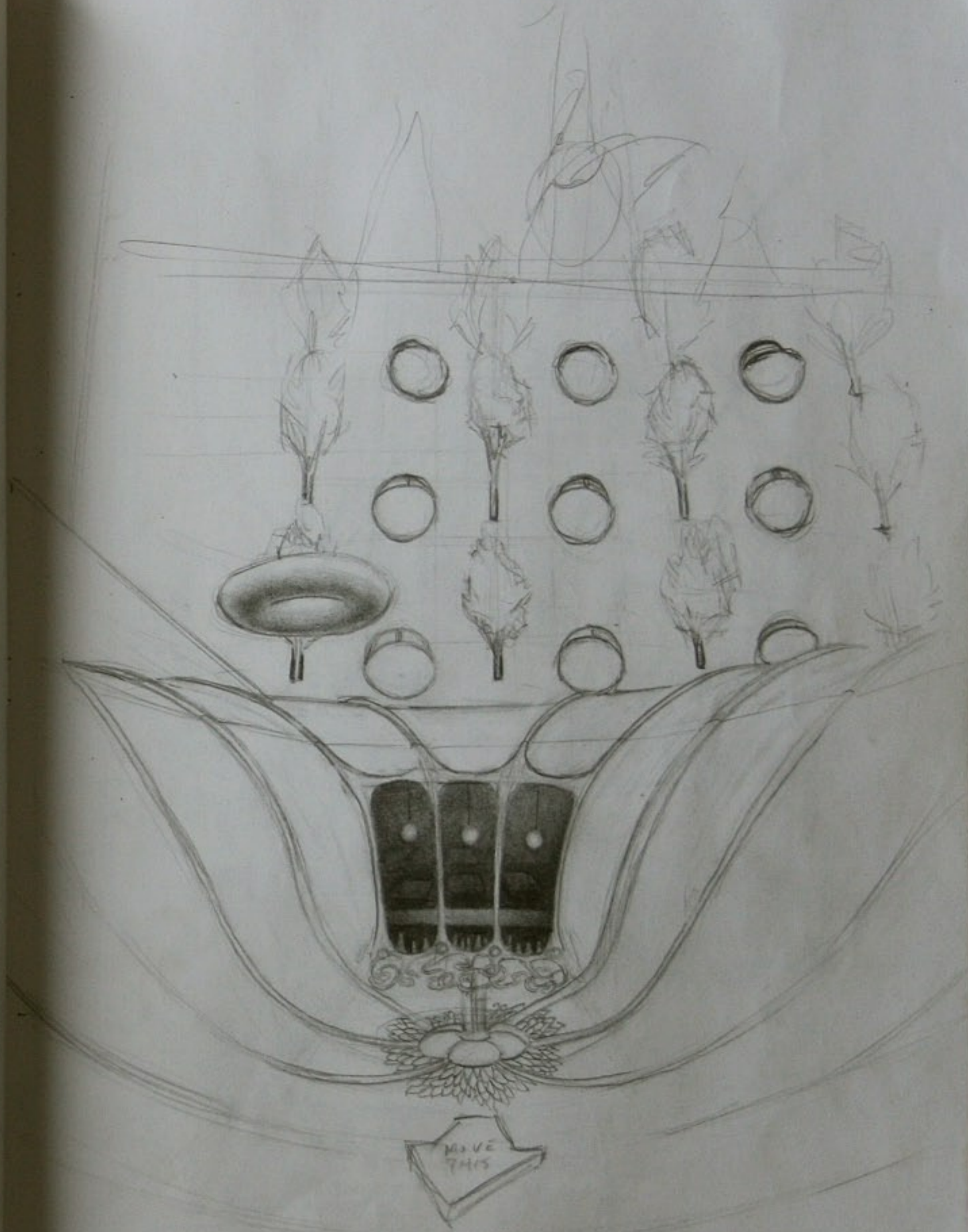



"DUCK-CRSTRICHES"

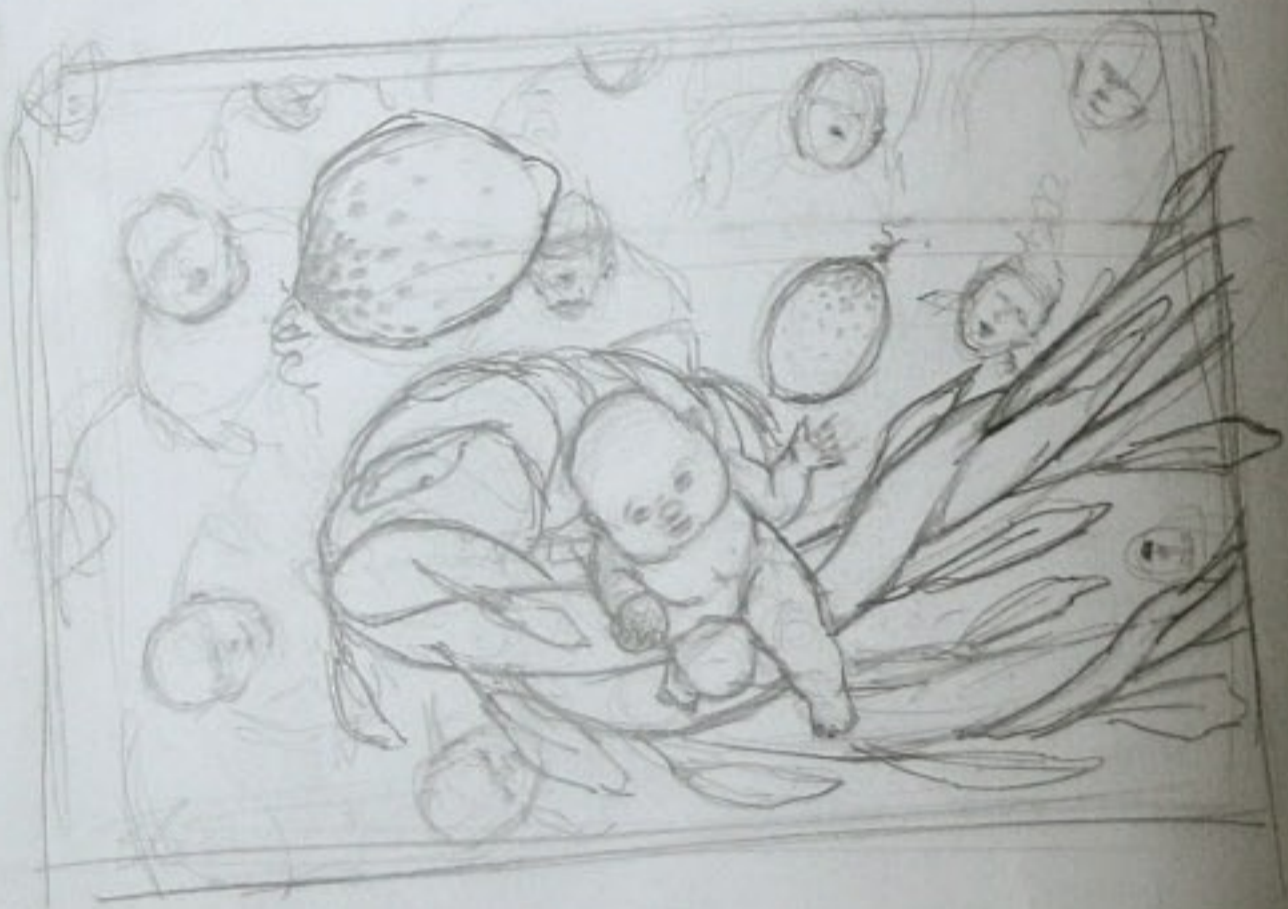

TIM
834 3144
419 6563 -CEL

THE CROWD COULD BE THE CHESS
SET CHARACTERS OR A "WHO'S WHO"
OF PHILIP'S CIRCLE OF FRIENDS

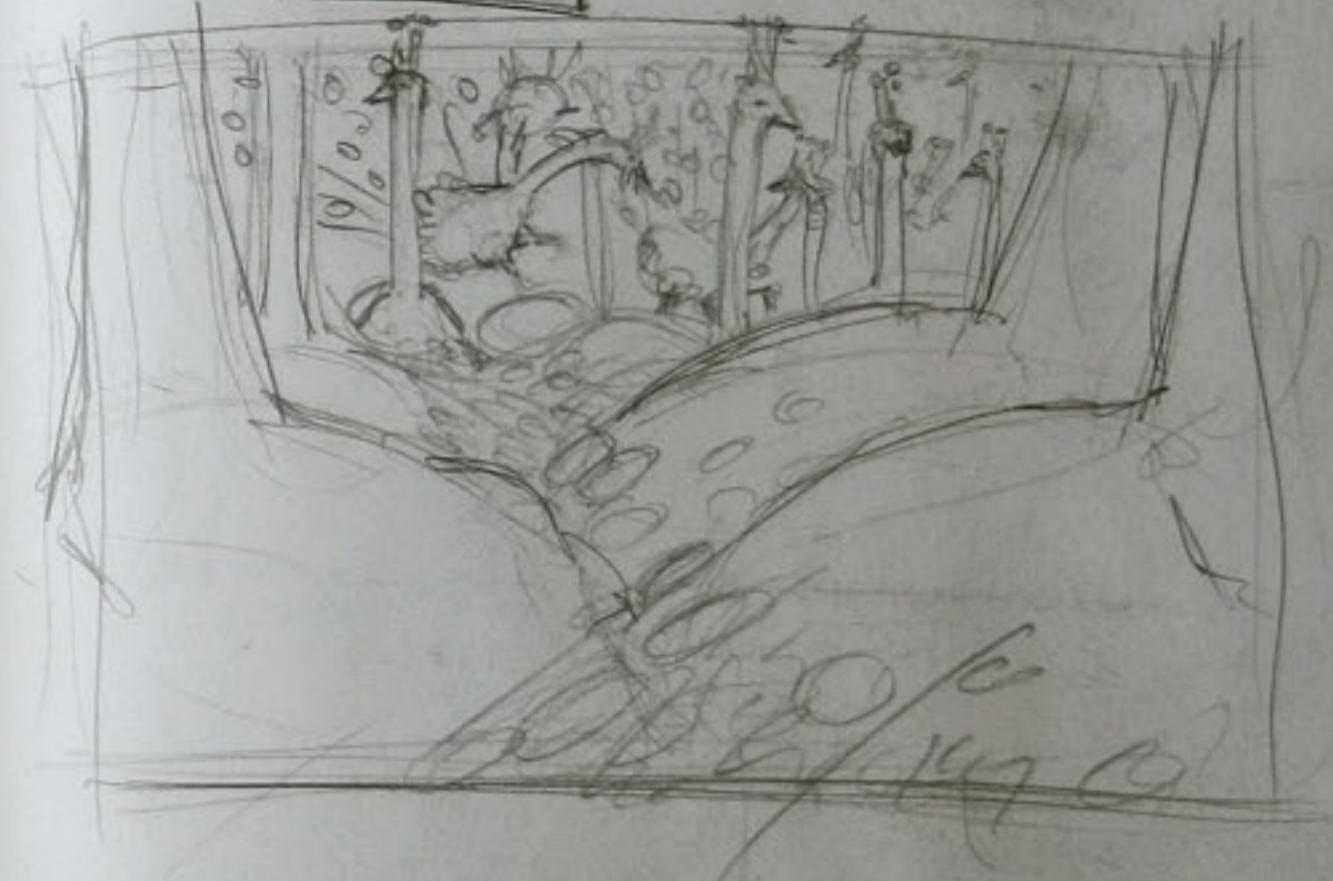



LOPEZ
213 9530 P
252

310 558 3168
10319 VENICE
MOTOR



PUKET

WOOKY



SS 3 EEX
E 120 MM

4242 ST.

RUTLAND
 CHATSWORTH
 20845 PRARIE ST
 (DESOTO)
 818 718 7696

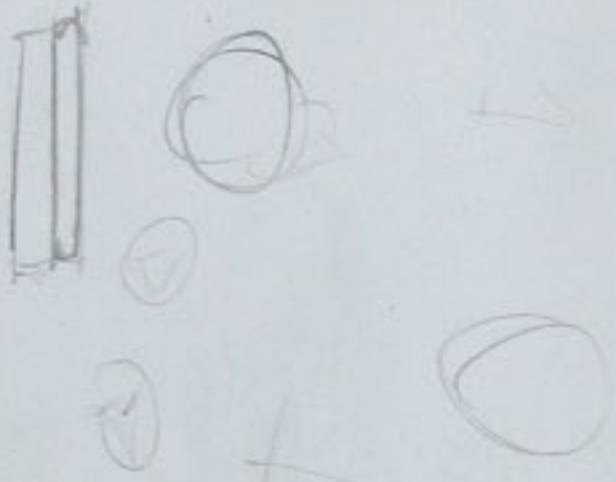

H-MED 79017066758

MASTER
 166924400

DSL
 (562) 598 5394



- MOTION CONTROL KIC
- 4 CT SYSTEMS (RAMATED)
- FIREWIRE CAPABLE
- FILE RECORDER (W/DRIVER CHAPTER)
- HARD DRIVE SPACE (800 GB FIREWIRE)
- VACUUM PRESSURE TABLE
- MILL & LATHE
- CATALOGS & ACCOUNTS

HILLSBORO
 VILLAGE
 SYLVAN PARK
 GREEN HILLS
 BRENTWOOD
 BELLEVUE

2048 x 1556
 1828 x 1332

220 FROM LEFT

1828 x 1050 (1:61)

MACW
 51446318

PAPER MART
 800 745 8800
 CUST.
 #302576

PHONE 239 5315
 WESTWOOD 6069

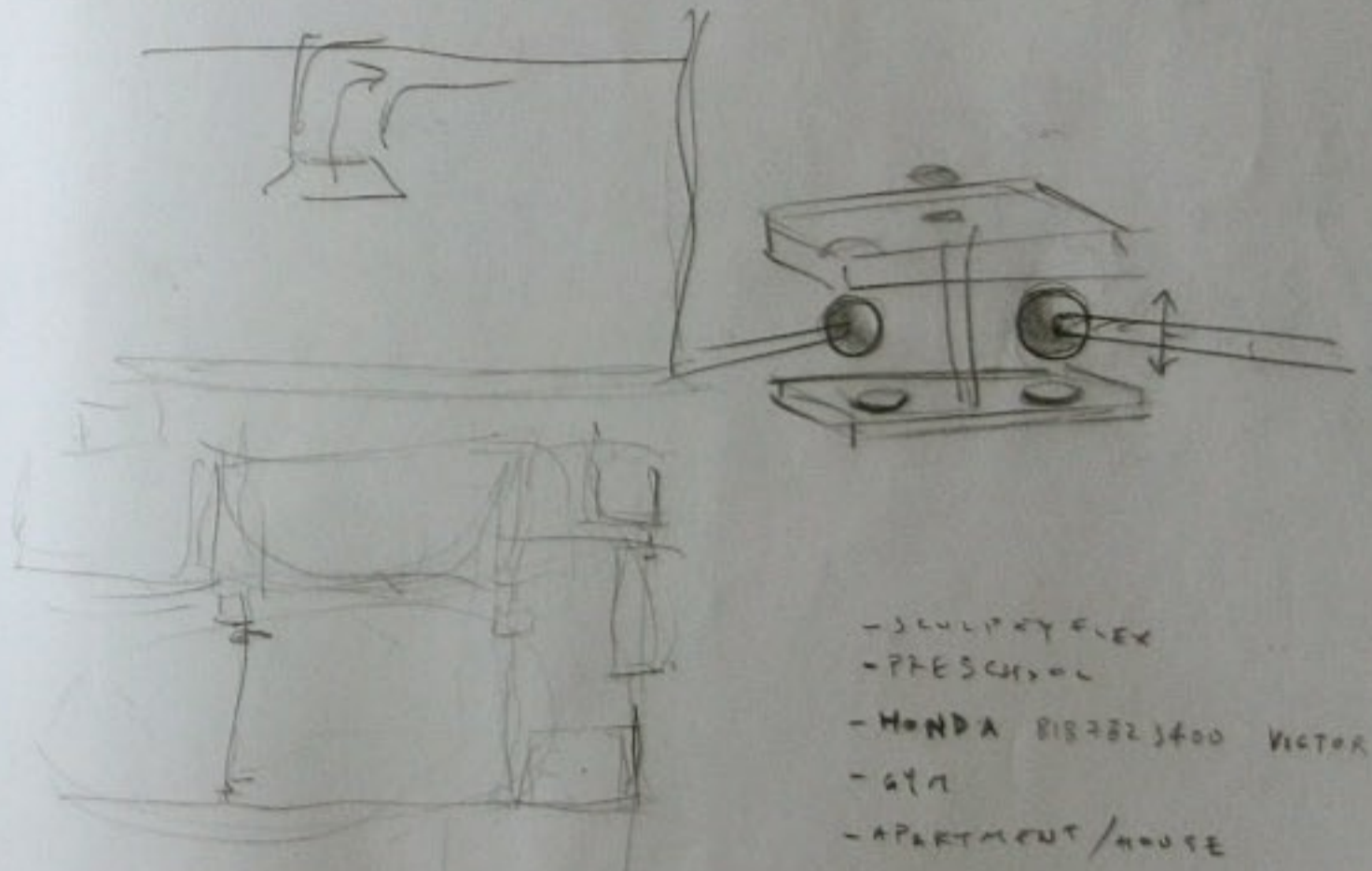
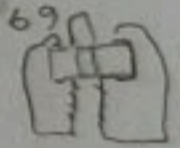

- SCULPTURE
- PFECHER
- HONDA B187823400 VICTOR
- GYM
- APARTMENT/HOUSE

82F000F10PF

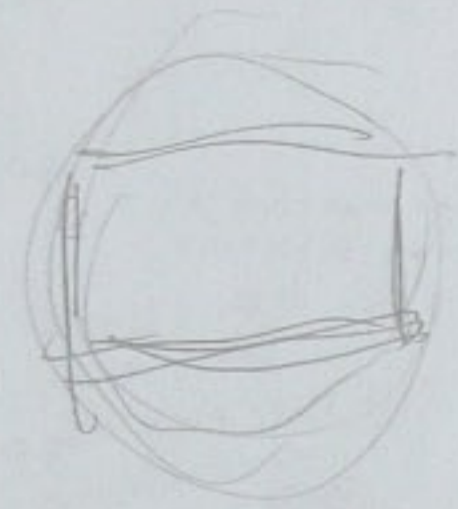

60MM
2128
#8757
90394
3/4 CB LENS
LOU-1

CAPMAN 0610

800 300 2800
NICK 70

Samy's Camera

CHRISTY JEWELL
Pro Department Assistant Manager

323. 938-2420 • fax: 323. 937-2919
200 So. La Brea Avenue • Los Angeles, CA 90036
www.samys.com • E-Mail: samys@samys.com

0610

SHUTTER BUG KEH
BOUN CRAWFORD
CRAWFORD PRINTING

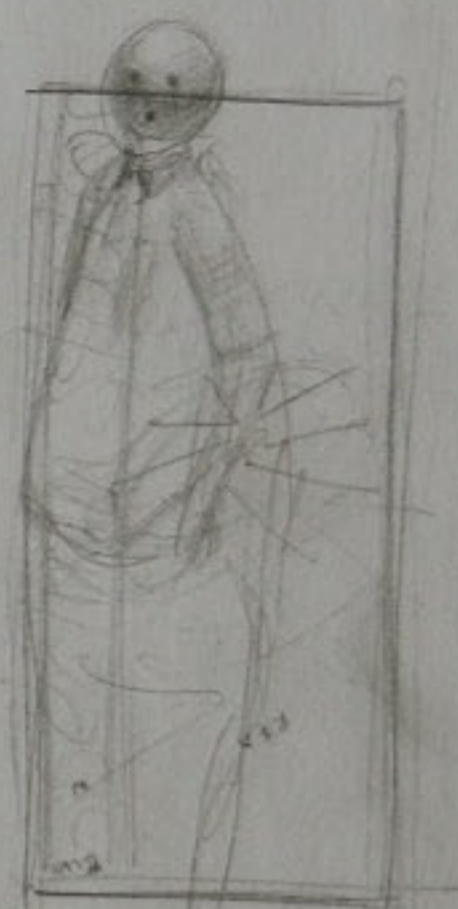
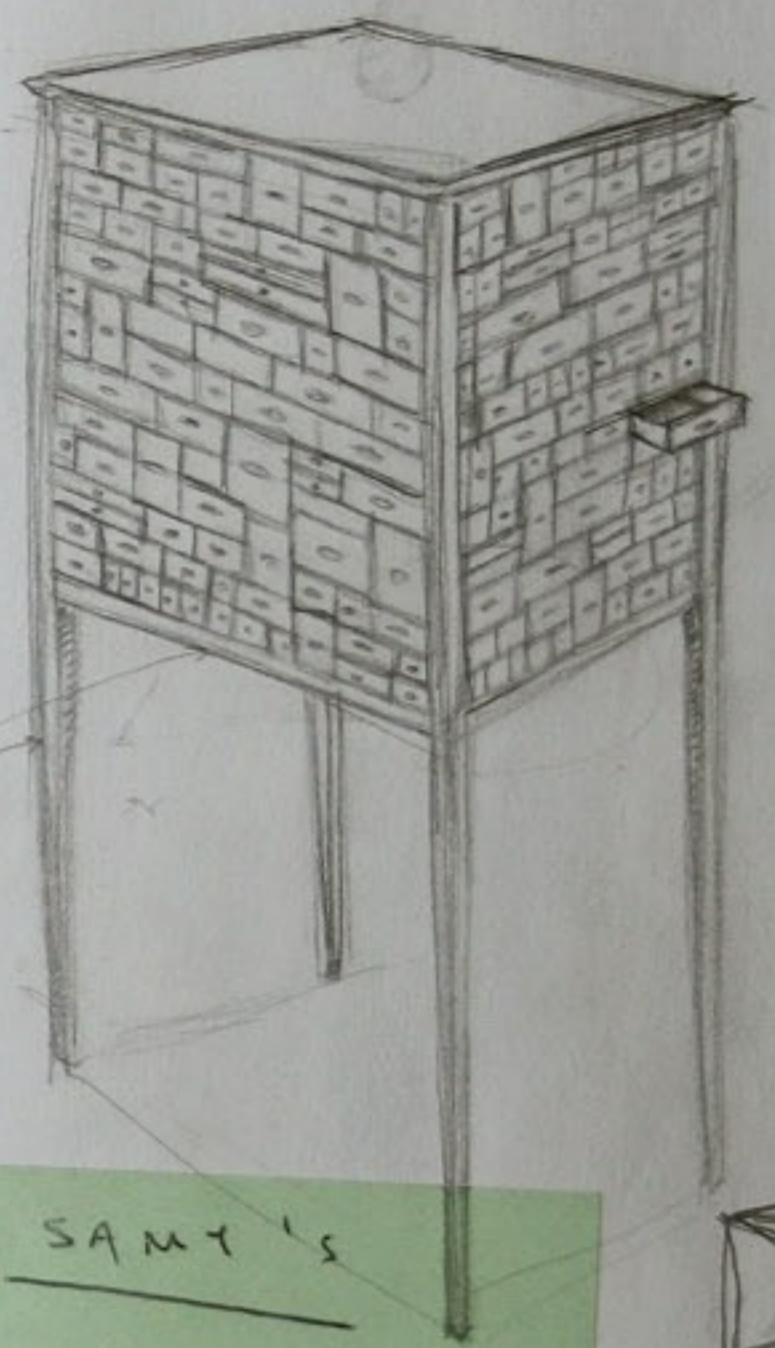

SAMY'S
323 938 2420

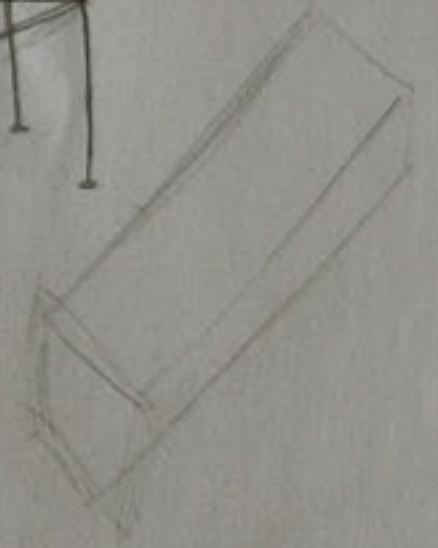
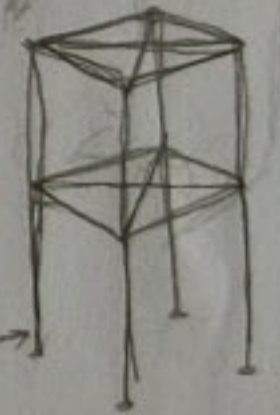

**Una Nota De Precaucion
De Matty Mattel Para
Los Padres De Familia:**



NO DEJES QUE NIÑOS JUEGUEN CON, O TOQUEN
BOLSAS DE PLASTICO; SE PUEDEN AHOGAR O SOFOCAR.

Supervision parental es la clave a la seguridad de sus niños.

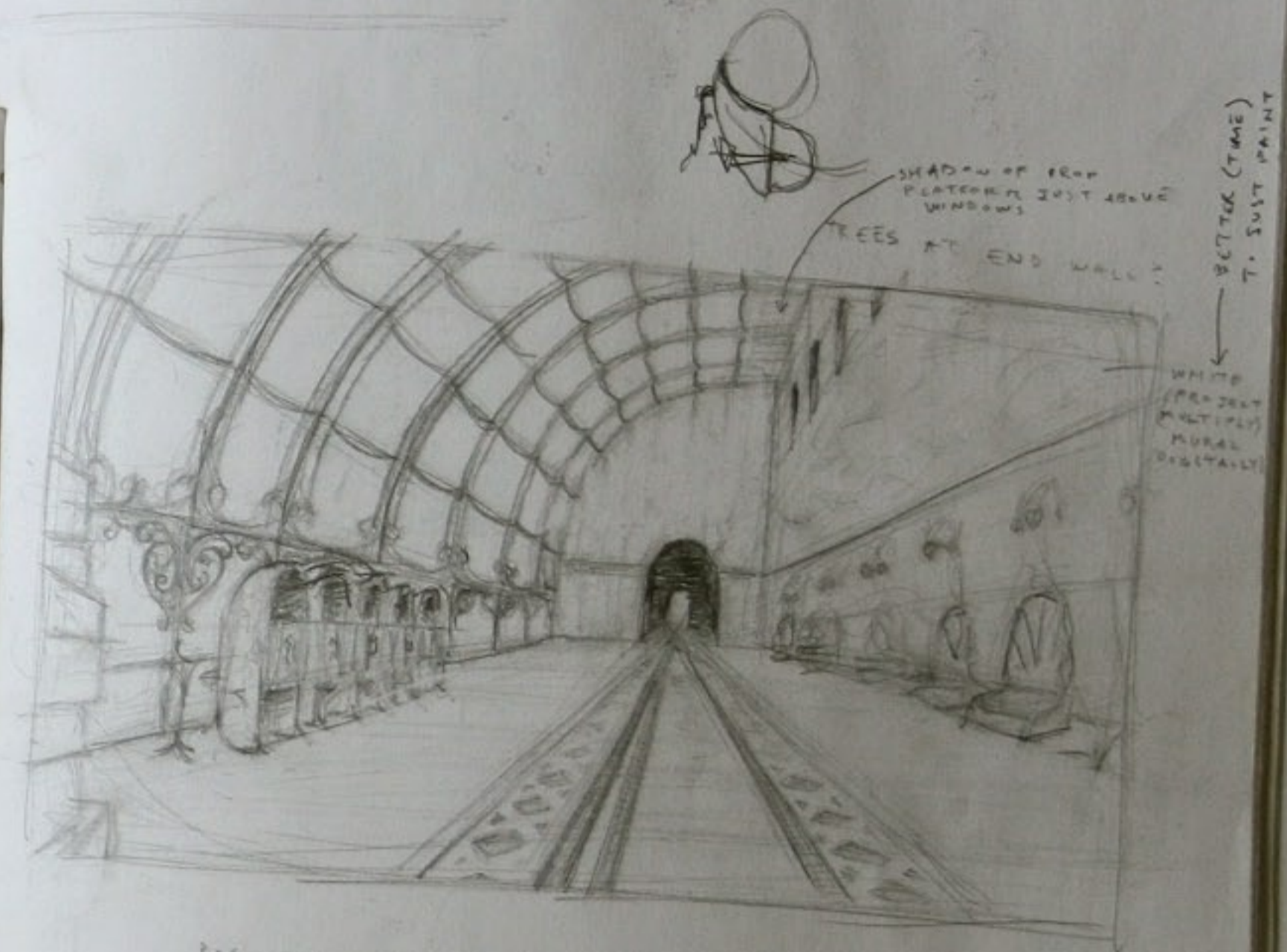

POSSIBLE THEMES FOR MURAL:
- A VIEW ABOVE THE CLOUDS, WITH EIGHT LEVEL CITY PLANS
- DANCING-STYLE FLYING MACHINES FLYING AROUND
- FLYING AMONG PEACOCKS

SHADOW OF IRON
PLATFORM JUST ABOVE
WINDOWS
TREES AT END WALL
WHITE
(PREDENT
MULTIPLY)
MURAL
DETAILS
BUTTER (TIME)
T. JUST PAINT



WE WANT YOUR CHILDREN.



PIN ON TREE
FOSTER KLIEN

64

FILM
-PR-PRODUCTION
STILLS
NEWS
DATES
AUDIO
VISUAL
VIDEO
PICTURES
BIB
11-2-71-43

MUSIC
-SIXPENCE
-CHEVELER
-WATERBURY
-LA SYMPHONY
-BURLAB'S
-BEMUS

COMING
INTERLUDES
-SPACED OUT



SIXPENCE
NONE THE
RICHER

GRADATES



ABOUT
SQUINT
MUSIC
FILM
SIXPENCE

MIRK 7-6
DINNER 630-800
PLAYERS 8-10



THE PRODUCERS

JAY, THE INDUSTRIOUS MEETING-MINUTE-TAKER



DON'T
REMINDE
ME
THAT I
SUCK



CELECO
JOHN COUZZI
909 481 0148
4648
XTRM E MX

- "BREAKIN' THE LAW WITH CHEVELLE"
SQUINT WILL COVER YOUR SPEEDING TICKETS WITH CHEVELLE
- SQUINT GREETING CARDS FOR ALL THE WRONG OCCASION
- PRES-CAM (VIDEO LOOPS OF STEVE "WORKING" AT HIS DESK)
(LIGHTING THINGS ON FIRE, DOING FUJI, CHEWING OUT EMPLOYEES, BLOWING BUBBLES, PICKING NOSE, EATING)
- MAD LIBS



373 9400
RASKIN
BROOKS KATZMAN 901 1080
SOUTH CHARLOTTE

- STEVE TAYLOR
- DAVE PALMER
- STEPHEN FRENDERGAST
- LINDSAY FELLOWS
- EAT SHARTZENGRUBER
- JOHN BUTLER
- ED BUNKER
- TIFFANY LANG
- TIM NAYTER
- MARK NASH
- ED BUNKER
- LEA FULTON
- JONATHAN RICHTER
- SARAH RICHMOND



FAT



SS
and
LUT
CPUNG
TON
D
LEX
8
H
L
DN
LL

VERNICE
321
3148

JIM
FREE
383
3111
626
EWING

SOUTH
WOOD
CIRCLE
4904



PAUL
383 6600
125 BLACKBURN AVE
1100 2+1

343 BARNES WOOD CIRCLE
170 ALELA WOOD 4904

SALE 225,000
312 5279
BENTON & GRANTLAND

440 (WOOD)
24

Don Barnes
303-6472
Duplex

ERA
109 LAUDERDALE
292 3552
ANNETTE WINTERS
352 4721

422
PRARIE
ROAD

DSL IN NASH
288 321 2375

800 753-0223
873 8846

CEL
615
429
9540

PHONE
615
356
2453
BILE

INTERMEDIA
802 250 9349

MARK
DEUTCHMAN

5:30
5513 FAIRHAVEN DR
429 6801
RANJALI
LRA
WOODMAN
292
3552

2:15
406 GLENHARRT
366 6032
WOODS
JEFF
MARY \$995

RCK
242
6869
5100 ADWAY &
8TH



643
734
0665

TUES @ NOON
CORINNE
615 297 7549
173 TUSC-LO

BARRETT
976 MURPHREESBORO RD

440E → 24E CARRT →
R MURPH.
KAREN FONG
4700 LOS FELIZ BLVD #14
LA, CA 90027
OSBERT FLAHER: KENDEI CK
615 3008200

402 8TH AVE S.
\$700



BELLEVUE
256 2757
WHL

AMERICAN
FLIC BOOKS
ACTION MICROPS
HAPPY MEAL TOYS
GREETING CARDS
PING PONG BALLS
TATTOOS
SUNBRELLECTIVE



500 440 → 65N
VALINDA BURKS
292-8050 OFFICE
834 6249 HOME
830 5368 CELL

BILL SWARTZ
1440 → 146E
PKT →
PIFE
AVE
SOUTH
HILL
2008
8TH
3385



4-1820

- WASHER, DRYER & FRIDGE OUT
- RETAIR & REPAINT ALL BATHROOMS
- REPAIR CRACKS IN MASTER BDRM
- PAPER IN UPSTAIRS BEDROOM COMING OFF
- REPAPER KITCHEN CABINETS
- FIX VERTICAL BLINDS IN ENTRY ROOM
- PINING ROOM LIGHT BROKEN
- FIX HOLES WHERE TOWEL RACK IS FALLING
- SMOKE DETECTORS HANGING DOWN
- FIX HOLES IN DOWNSTAIRS BEDROOM
- FAUCET LEAKING IN LOWER BATHROOM
- SOME BATHROOM TOWEL RACKS MISSING DOWELS
- MASTER BEDROOM LIGHT OUT
- VERTICAL BLIND MISSING HANDLE (UPSTAIRS BEDROOM)
- ALLERGY CLEAN CARPETS?
- TOUCH UP BASEBOARDS
- HALL LIGHT UPSTAIRS BROKEN (MAYBE BREAKER?)
- KILL WASPS NEST IN DOWNSTAIRS DEN

QUESTIONS
CAN HE PAINT

2
4
3
3
62
21



AMY
(615) 385-7017



JAMES RENFREW @ SCOTT & DEBBIE
WELLMAN
1250 EAST A ST
OAKDALE, CA 95361
(209) 842-3203

- Call online about cat
- Tang + Tom's milk
- Beaching place
- Samon (Purinton)
- Post office (Shop it today?)
- Charlotte Russe
- IKFA

ASK HER IF HER MOM EXHIBITS
THE SAME SELF-DESTRUCTIVE
BEHAVIOR?

GREEN HILLS GRILLE
2209 ABBOT MARTIN
610 292 1366



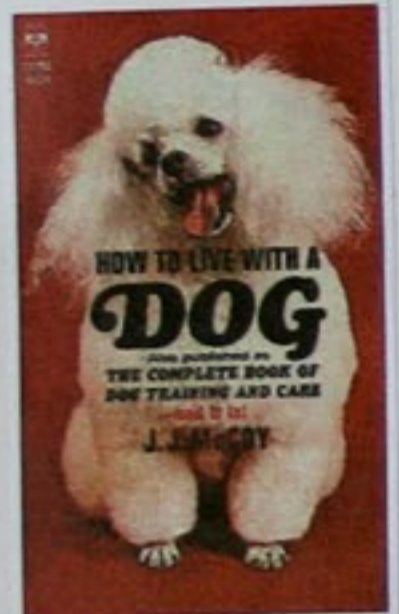
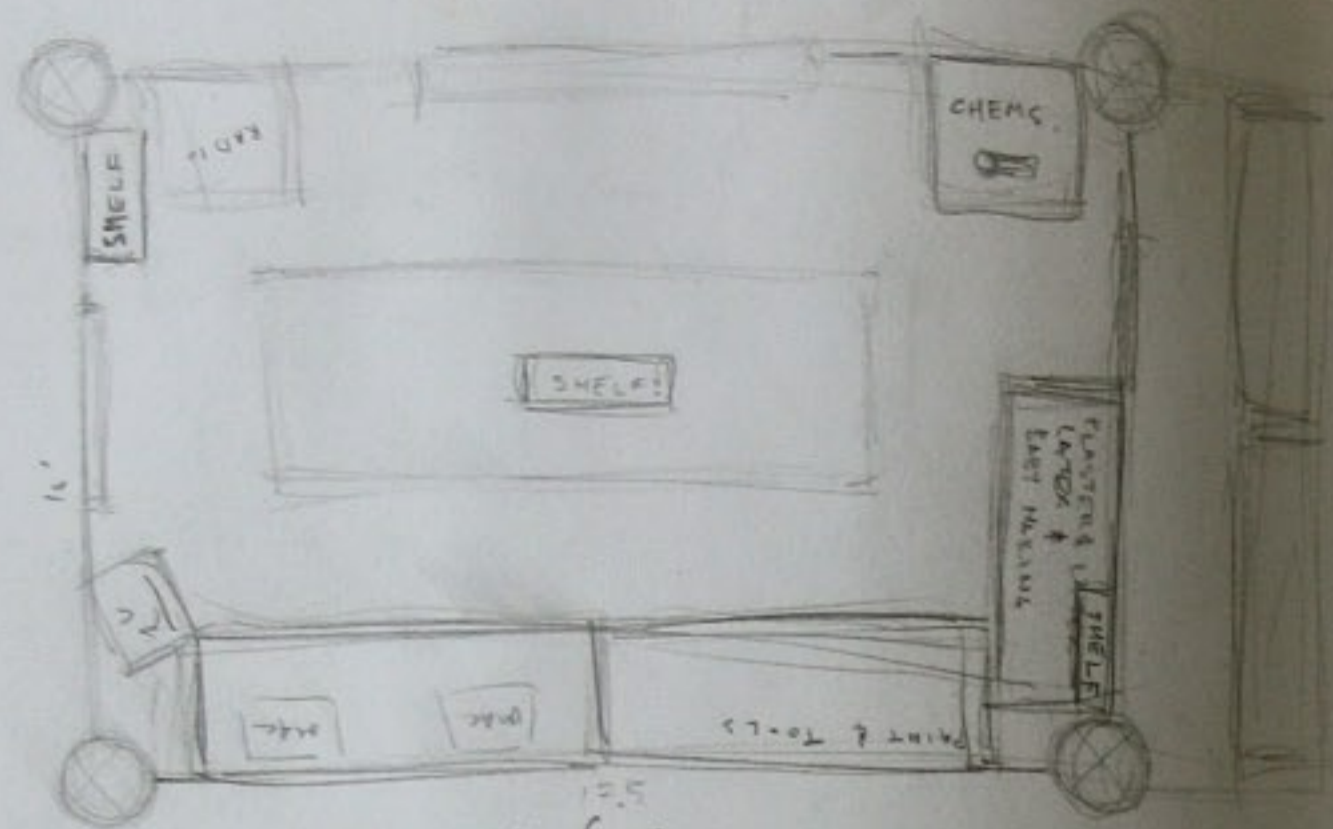

www.ozipa.com

THA VISIBLE CHOIRBOY

RICK
363854225
X4489

colorbook.com
STUDIO BAD.COM
THEPUMP.COM

\$180
227 7170
SARAH

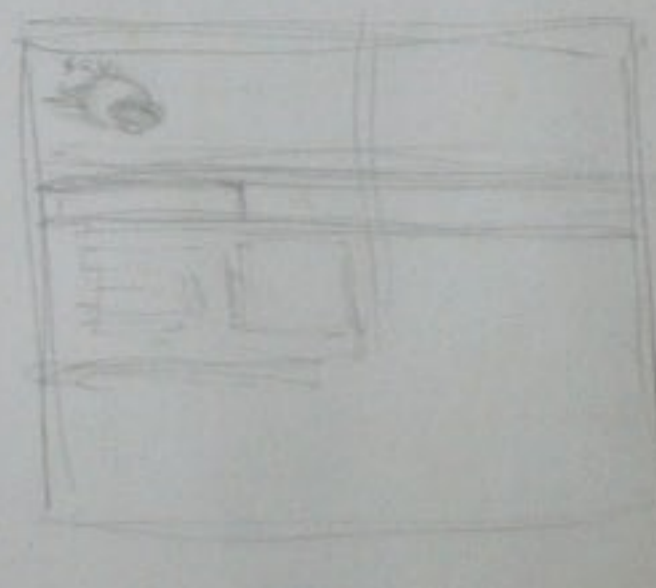

BACKGROUND
PLASTER MOLS
PLASTER & LATEX
DOG STUFF & PEOPLE STUFF
PRINTS
MILL & TOOLS
PREMELS
TOOLBOX
CHEMICALS
TABLE SAW
BABY MAKING STUFF
MOSAIC TOOL

INAR M MICRO
CRITICAL MASS
615 320
9400
615 256
5700
-SQUINT STUDIO SIGN FOR DOOR
-TOOL FOR MOUNTING FLOOR

AIT2
4049.95
LAMPLAND 2425263
WWW.EZSYSTEMS.COM

SARAH
20549
SDX - 5500C/BM

329
ATTO EXPRESS
1716 691 1999

POSTAL
213 487 0663

3714665
P3856422
FILMG4
FILMG4
P3856493
ATTN: ACCOUNTING
772 370 8721
CASTEL
X56377

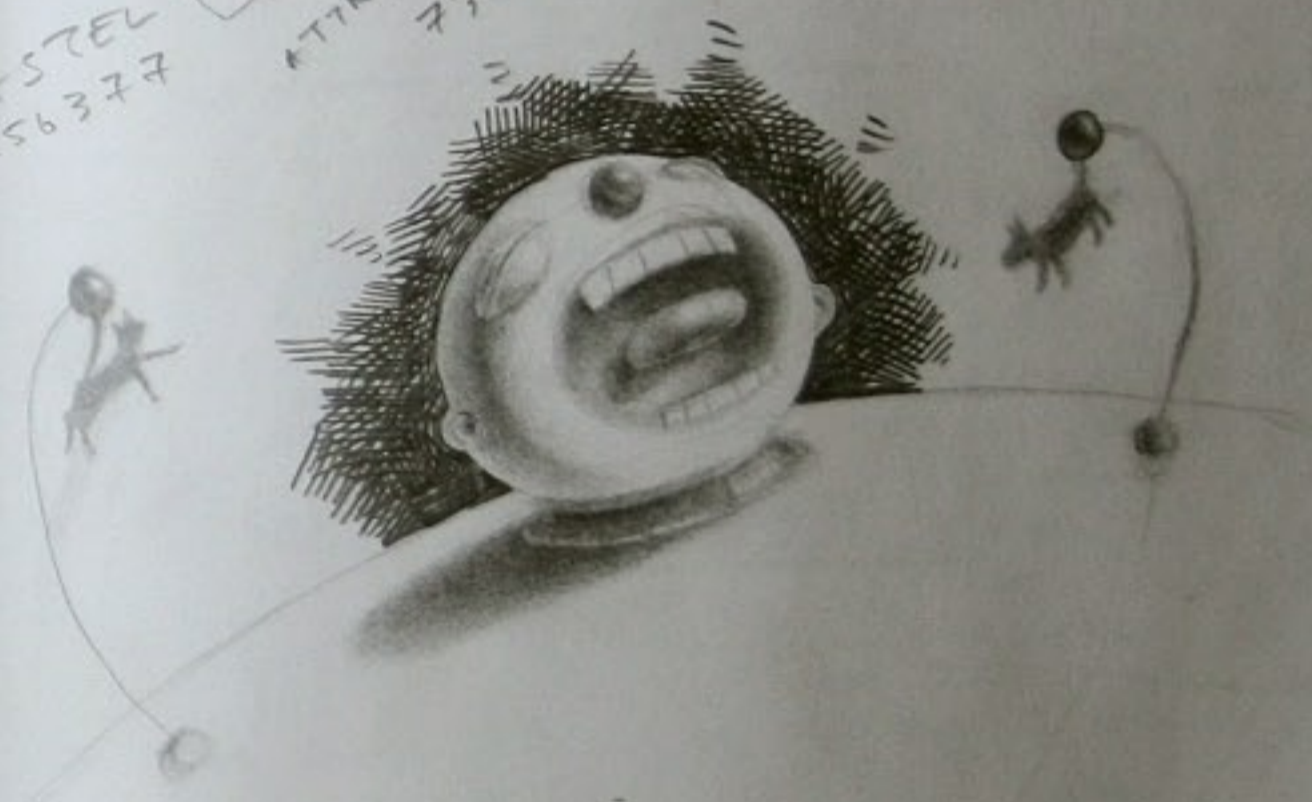



POOP SMOOCH ON CAT

FLYING CAR



BULK REGISTER

LEIGH LEADING A GROUP OF SCHOOL CHILDREN THROUGH RECENTLY FINISHED CORRIDOR

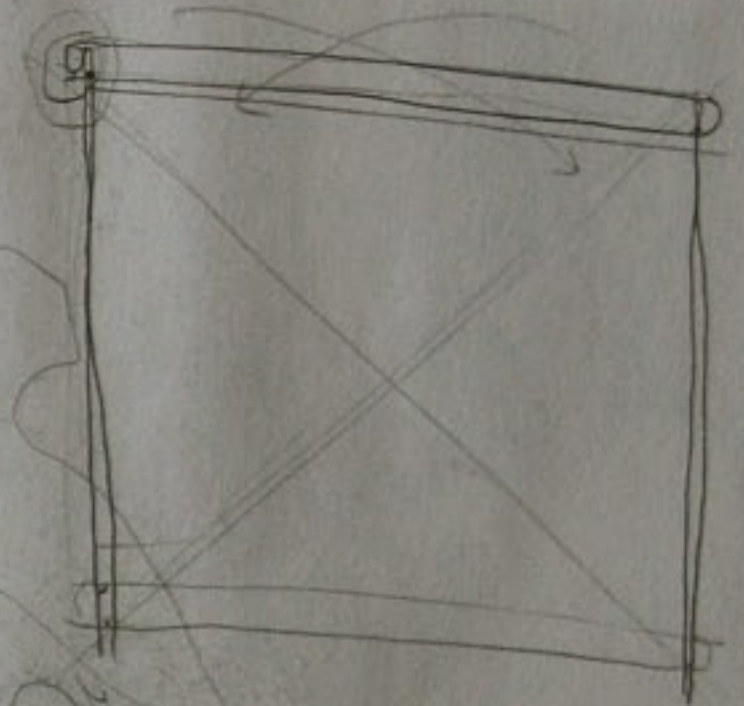

HEY - LO MONKEE



SCALE
SHORT
HANDS



H O R S E Y

$$\begin{array}{r} 265 \\ 24 \\ \hline 260 \\ 130 \\ \hline 315,60 \\ \times 60 \\ \hline 936,00 \end{array}$$



BLVIE



$$\begin{array}{r} 30 \\ 24 \\ \hline 220 \\ \times 60 \\ \hline \end{array}$$

D R A G O N



August 7th/8th
Mon. Tuesday

8pm
@ Kings Cross
After Hours
Theater



26 45 21

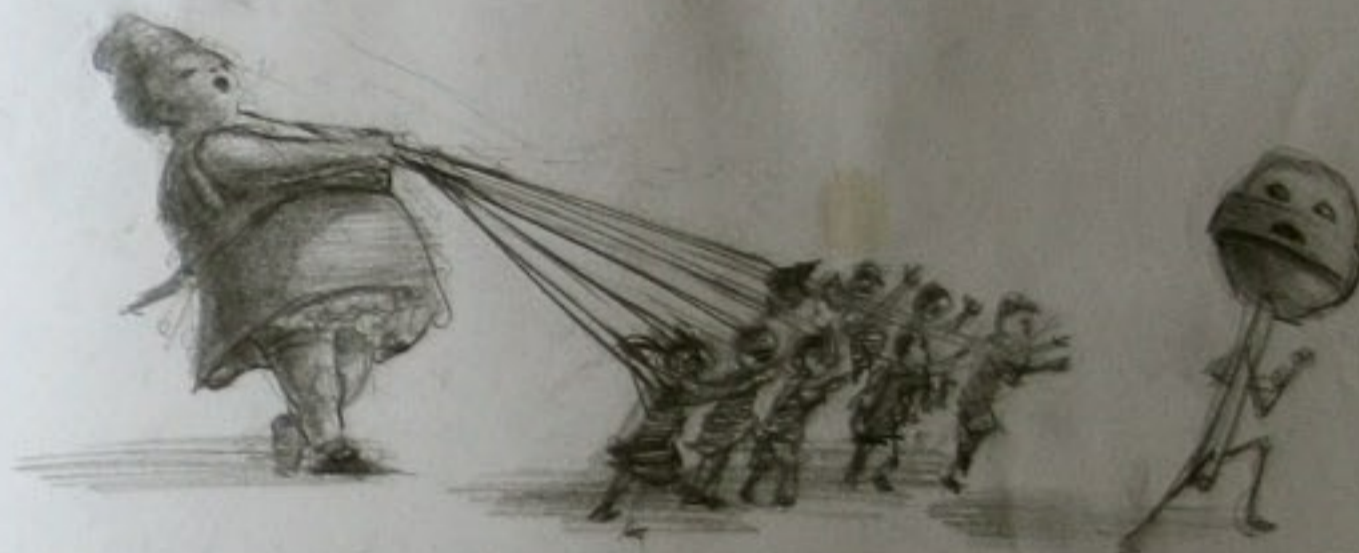

WINKY THE GRAPE-FLAVOURED SUCKERBOY

LAS
102 WET



P+B 137-cc.com

MILK
ID OFFICE
SHOTS
SONY TITANIUM
LAPTOP
V410
PDR-110



Are you copying me again?

YEAH!

DAN SANDERS - ALLERGIST

DR. FREE
800 797 4834

PRIME GOALS
ASK QUESTIONS TO...
SPONTANEITY
DEFIANCE
FOLLOWING (STRUCTURE)
TALKING TO KIDS
CURIOSITY
ACCEPTING UNDERSTANDING
EXPLAINING REASONS FOR BEHAVIOR

APPLIED BEHAVIOR ANALYSIS

TEACH
HANDS
SELF HELP "I" &
SOCIAL "TOU"
COMMUNICATION



PERFECT SKIN MARK

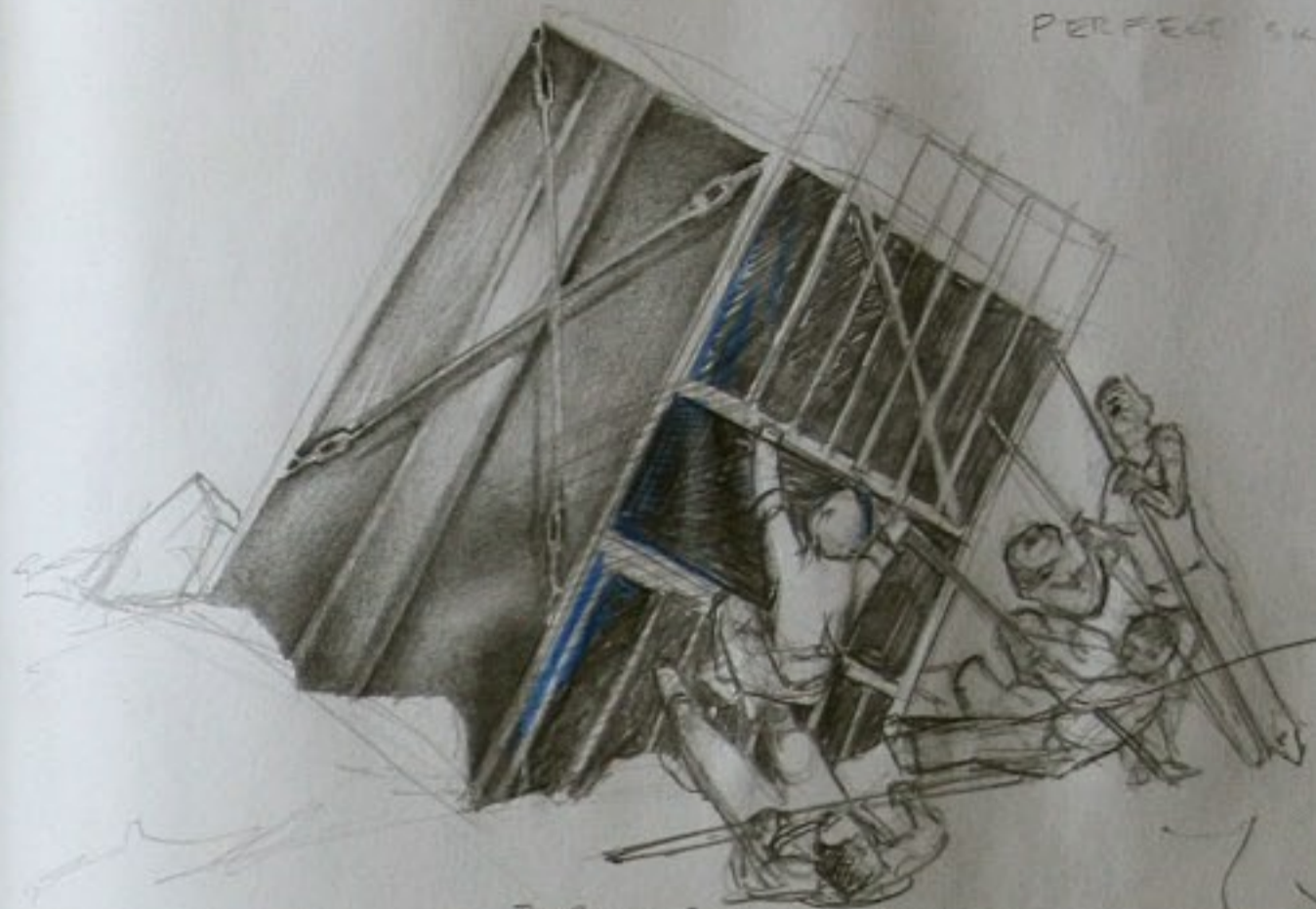

THERMAL FORMING MACHINE

- TRAIN STATION WINDOWS
- TRAIN
- ARCHITECTURAL DETAILS

- LIGHTING GRID
- THERMAL FORM TABLE
- MOTION CONTROL UNIT

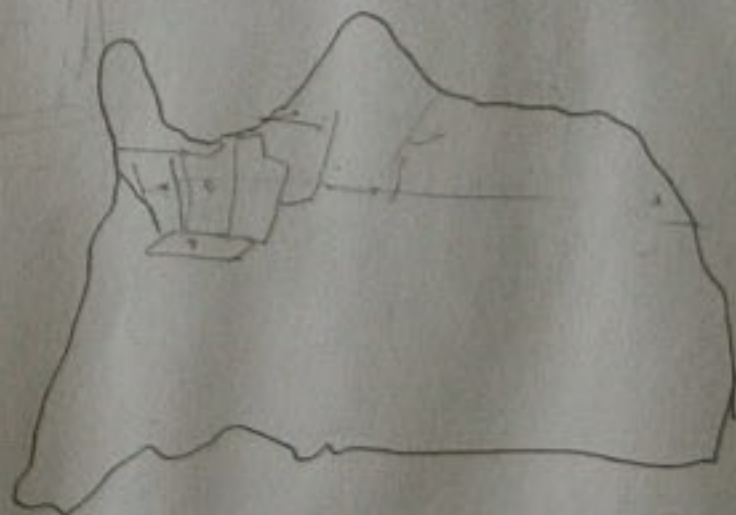

- Glue for treatment (preferably non-toxic)
- 2 door stops (round)
- tape
- kumogata
- extra drop cloth
- kumogata

- ATTITUDE
- BEHAVIOR
- COURTESY
- DISCIPLINE
- ENOYMENT
- FAITH
- GRATITUDE

SCALES!

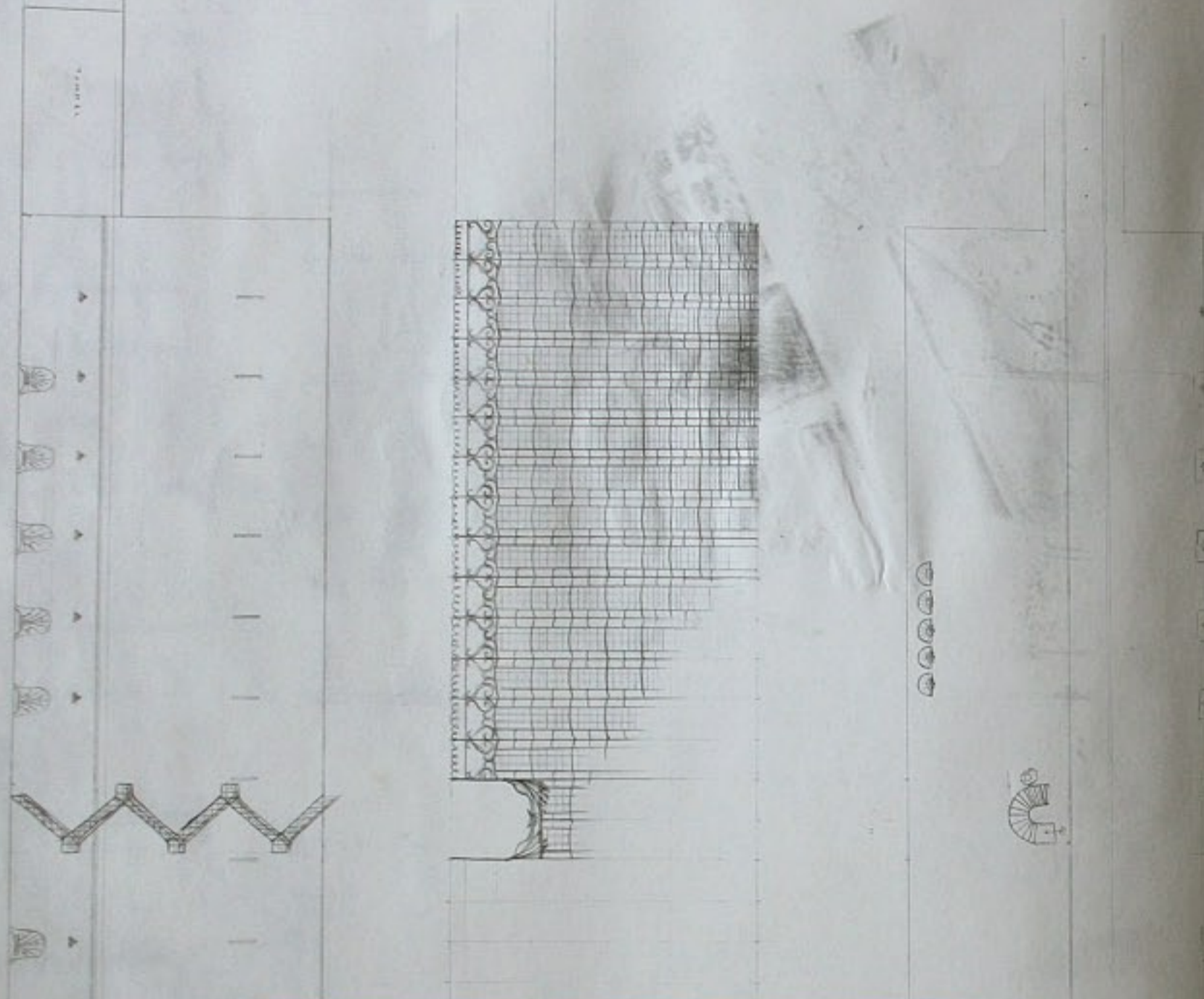

L.A. SYMPHONY

A: BROKEN TAPE DECKS

B: WHAT YOU SAY? (FEATURING FAT LIP)

■ CD ■ LP ■ CASS 12" SINGLE ■ OTHER



squint
www.microckers.com
www.squinterland.com

SHE HAD ARMEFULS OF LITTLE LIMBS FOR HAPPY CHILDEN EVERYWHERE.



NEW YORK - TRANSLOCITY

1800K / PARIS

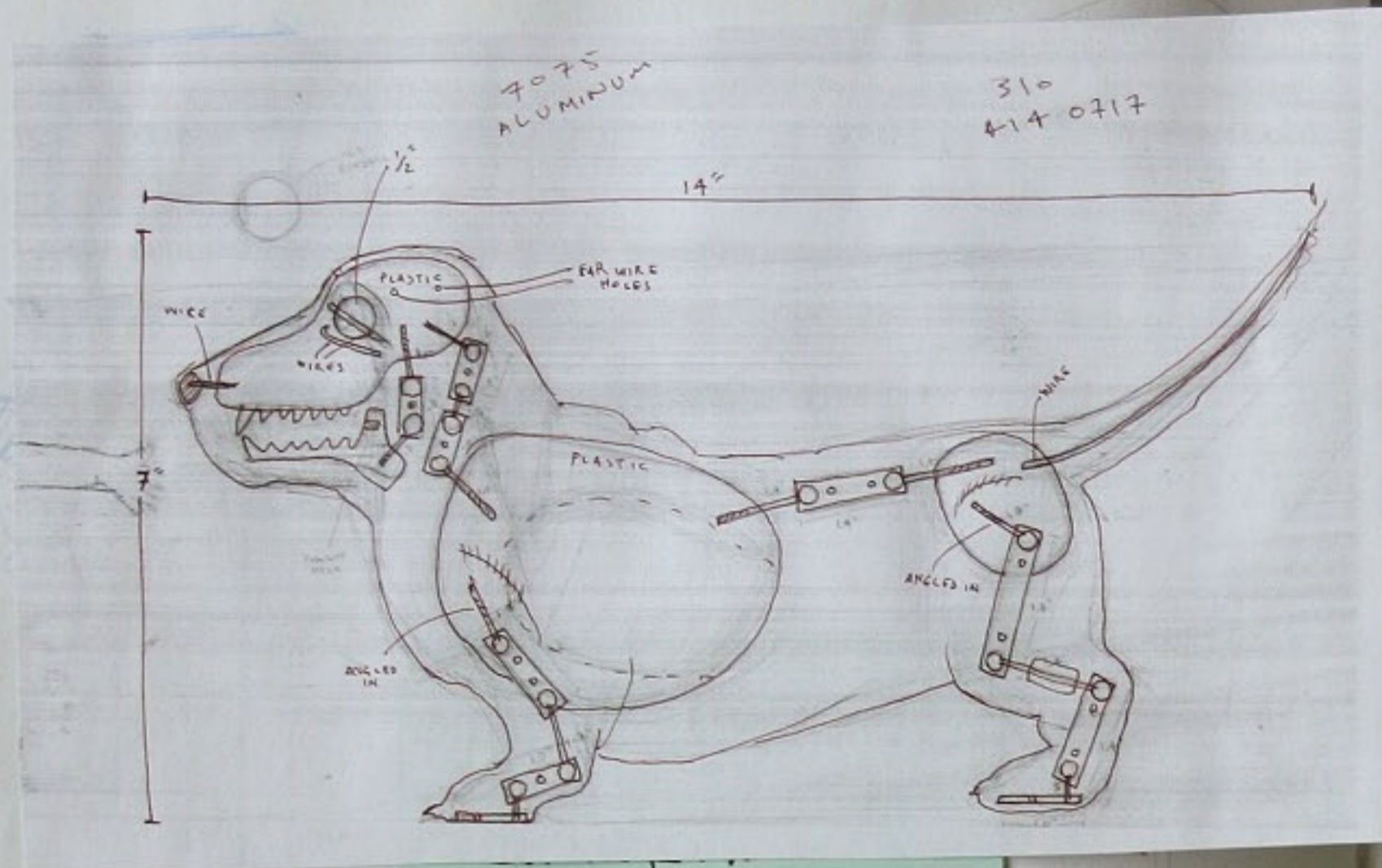

819 762 1384

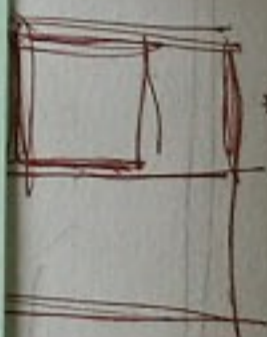

BLOWN-OUT WHITES
TEALS

REDS & ORANGISH-BROWNS



IN-DOOR
OUT-HATCH
REST-BED
ACTING-RUG-TIRES WIND
INPUT-TELEVISION
OUTPUT-

160
200
300
1000

WING WORLD
THE 2400

INK TOM I



PORCELAIN HEADS AS CONTINUITY

HE ASKED FOR A DOG



I GAVE HIM THIS

POOR KID

The bulgers
Hungarian Women's Choir

- INDUSTRY MUSIC VIEWS
- TASKS
- LINKS

PRIORITY DEADLINES FOR PROJECTS

- CALENDAR
- TASKS
 - OUT OF TOWN
 - BAND LOCATION
 - ED'S PROGRAMS WITH STORES
 - JAY'S PRESS PAGE
 - JOHN'S INFO
 - RADIO OVERVIEW

$$\begin{array}{r} 45 \\ \times 4 \\ \hline 180 \end{array}$$

| | |
|------|-------|
| SOMP | SARAH |
| | |
| | |
| | |
| | |
| | |
| | |
| | |
| | |
| | |

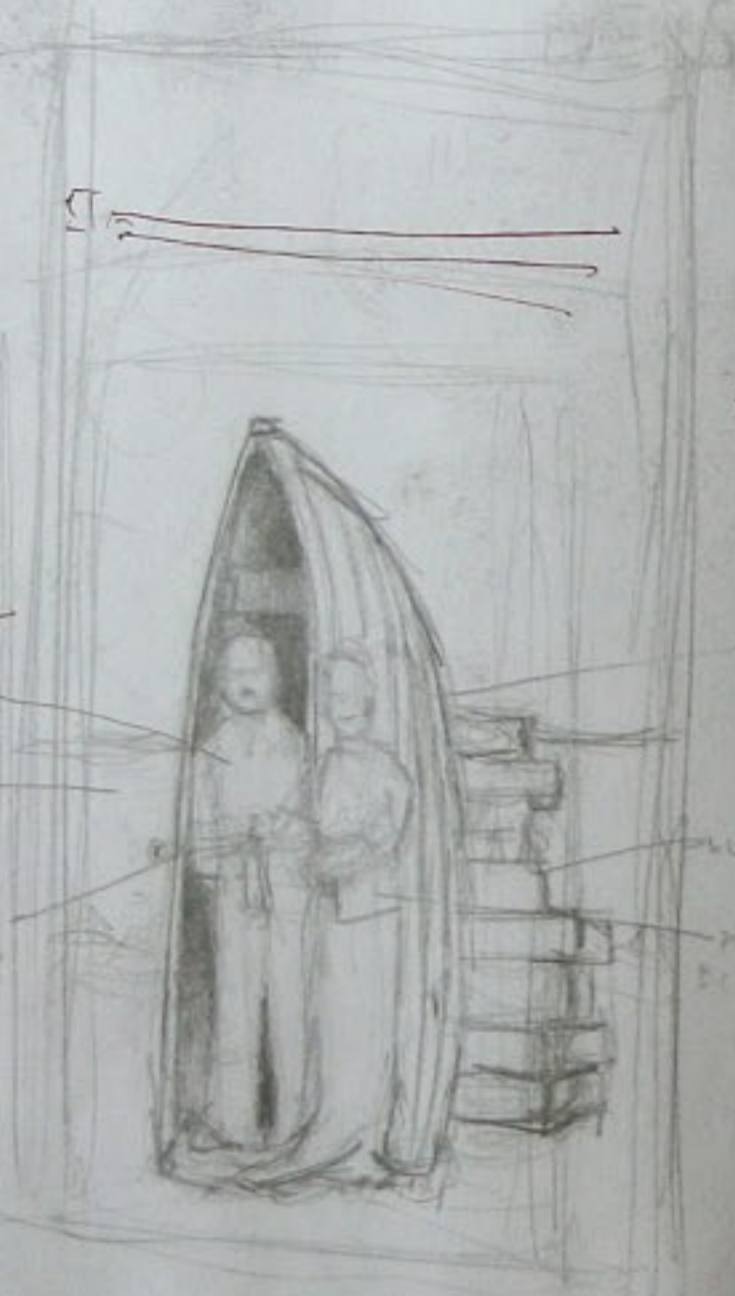

- WASP
- BLUE BLANKET
- LOGGERS
- PINK BLANKETS

SOUTHWEST IRLAND.

LEP 130 12:30

-LIFEBOAT

MON @ MARK @ SCHOOL LITER
 TUES @ KARI 5-7
 WED @ BETH 4-7
 THU @ KARI 1-3
 FRI @ BETH 3-5

- 3 AGGRESSIVE
- 6 COMPLAINT
- 3 WITHDRAWN

NEW YORK - TRAVEL LOGICITY

BOOK / ...

INSTRUCTIONS
 - TALK TO ...
 - LAB ...
 - ...
 - ...
 - TEST RECOMMENDS



HERE IS VARIABLE
SOME GET

SEVENTH PETROL
 RAYAN
 297 6663
 1611 S.
 OBSERVATORY

-ONE CHARACTER'S HOME IS THOUSANDS OF TIMES MORE EXCITING THAN THE SET (SOME DAY WE WILL SEE)

3,6,9

AGGRESSIVE
3

BO SCHE



PORCELAIN HEADS

SPEAKS SWAHILI 6



SPEAKS RUSSIAN 9

WORDS & LANGUAGE BY EVERYTHING ELSE IN SET IS IN ENGLISH (SUBTITLES, TOO)

TYPE III

VANDALIZES TEXTBOOKS
 DEMANDS REACTION





Handwritten notes and sketches on the left page. At the bottom, the word "HANDS" is written in large, red, outlined letters. Above it, there are various scribbles, including a smiley face and some brown and blue washes.

$\frac{1.4}{x} = \frac{3.2}{100}$ 77.2% 128.57%



ABONO
T = ESTIERCOL
FRIENDS AMIGO
CLOTHES = ABRIGO

"THE VIOLIN SHOP"
-MOUSE IN FOR COMFORT



SELF HELP

COGNITION

SOCIALIZATION



LOREA SAUFORD

PROGRAMMING DECISIONS

GEN REC

NEED TO BE
@ IEP MEETING

NORM
TENNEWBAUM - ARC ADVOCATE

321-5699

LOOK UP ROLE OF SOCIALIZATION
IN PRESCHOOL

251
DUNCAN

BUY SOAP FOR SCHOOL



DR. WALLACE
R.I.P.

AMERICANS DRIVE
MARTHA VAUGHT
RURAL AVE

IRON
SURROUNDING
FEATHERS

MARGARET
HORSEWELL

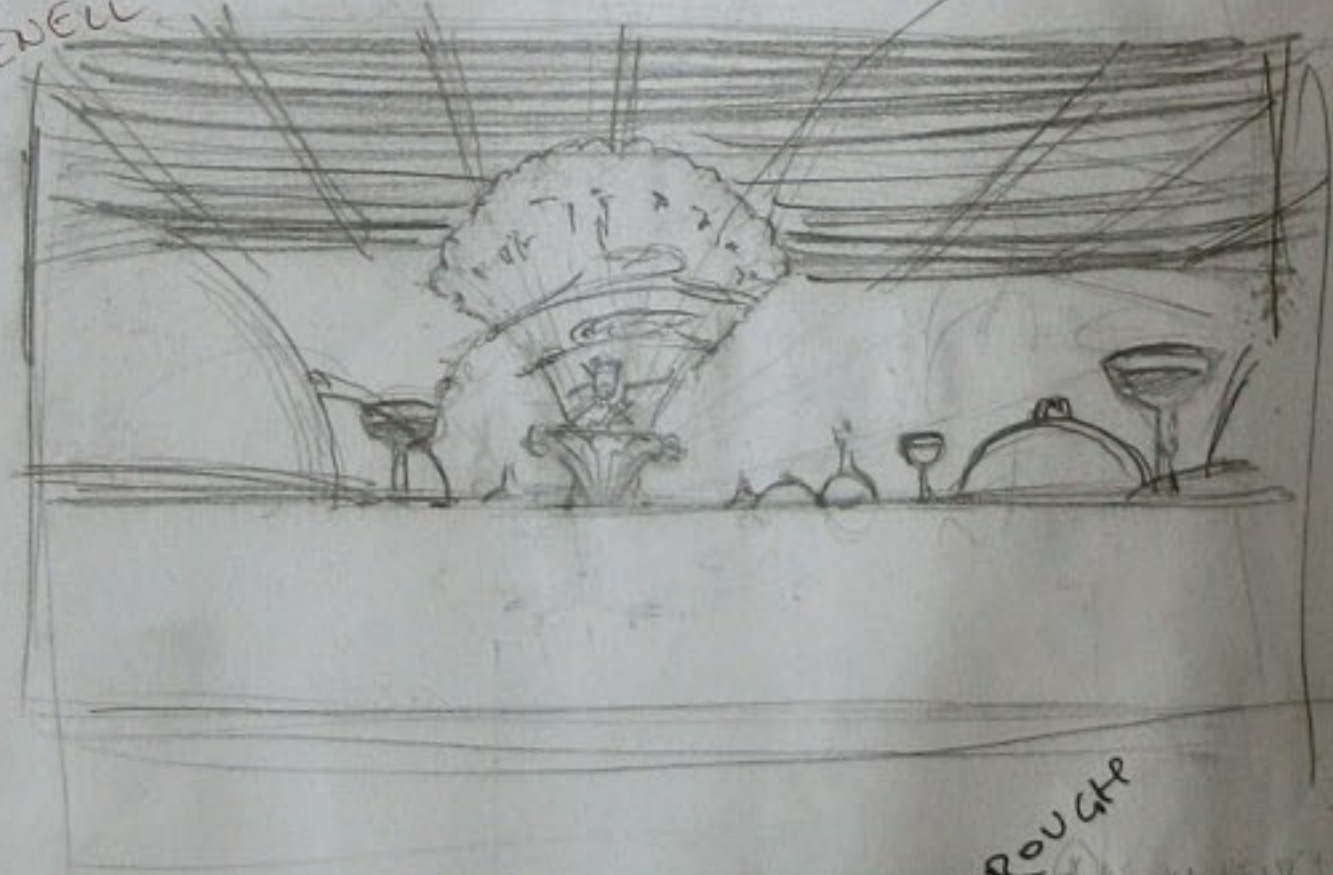

THOMAS ROUGH

AS IN HEIST JAMES
AS IN COMPLETE

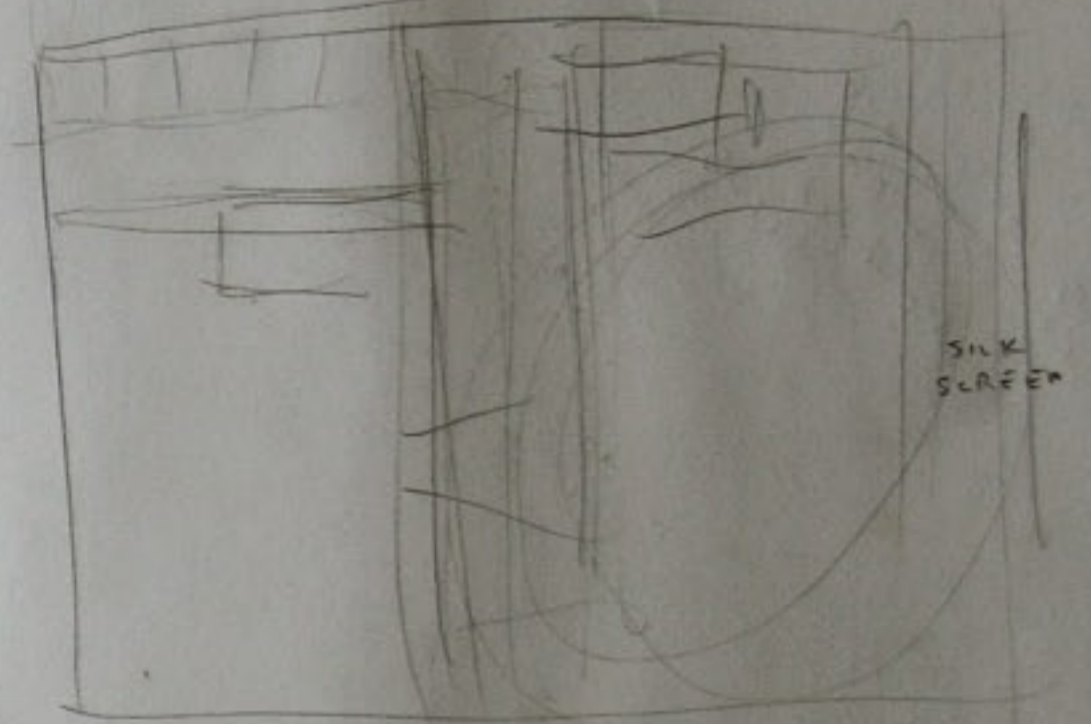

SCARY PICTURES
OF HUMANS INTERACTING w/ PEACOCKS



251

KENTON
NELSON
99 SOUTH
FRYMOND TUE
PASADENA, CA
91105

To Juan
New Orleans
(504) 283-2236
Pasadena
(John Rodgers)



SUCKS
A LOT

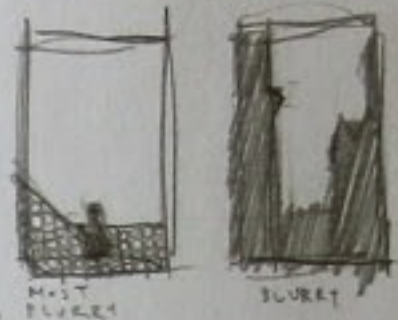

BACKGROUND
SHOTS



11/7/11

528(N) → TURNPIKE(N) → 75



7 COOK FOR BREAKFAST & LUNCHES
8 BE @ WORK

9 }
10 }
11 } PRODUCTION
12 }

VIOLIN @ LUNCH

1 }
2 }
3 } WORKER PREP
4 }
5 }
6 }

7 BE HOME / FIX DINDIN
8 EAT & CLEAN UP
9 BATH & BED
10 }
11 } PAINT & BED
12 }
1 }



- SINGLE CD DESIGN
- ASK SARAH STUFF
- BEHIND THE SCENES FOR DVD
- LIVE SHOWS AS WELL
- COST OF FLIPBOOKS
- VALUE WEB & PFR
- FRONT PG & NEWS & JOURNAL

ONLINE
ROR SHACK
FULL SCRIPT

BEFORE THEY GET
PICTURES, TAKE
POLL.

R+N WALLAS
(714) 985 1347

BOWLING ALLEY

7000 HQ

-MERGE LOAD
OF LIGHTS

GO TO TOP PART
CEMETERY IN
EQUAD-R

2000
BLAIR

CORBIS



BAD DIDN'T FOLLOW THE DREAM.



DEC
4-2003

EXPLOSIONS
FIGHTS

- CALM BEFORE STORM
- CHASE
- FALLING & HITTING THINGS ON WAY DOWN
- STRUGGLING BETWEEN LIKE FORCES (EQUALED)
- TENSION BUILDS
- THE REJECTED IS REJECTED
- THE HERO FALLS (EASILY)
- THE WEAK WINS
- THE WORST THING HAPPENS

SOMETHING BIGGER THAN ANYTHING SHOULD
BE ALLOWED TO BE

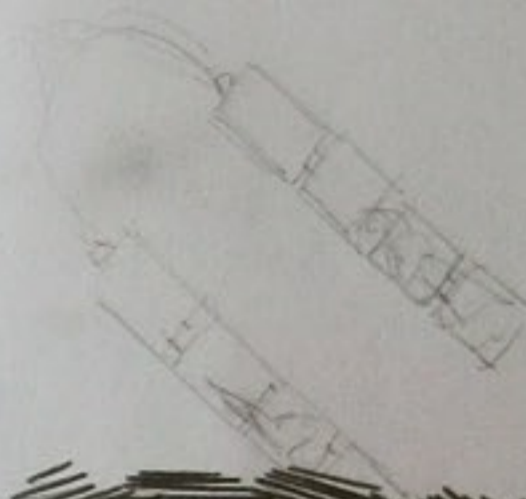
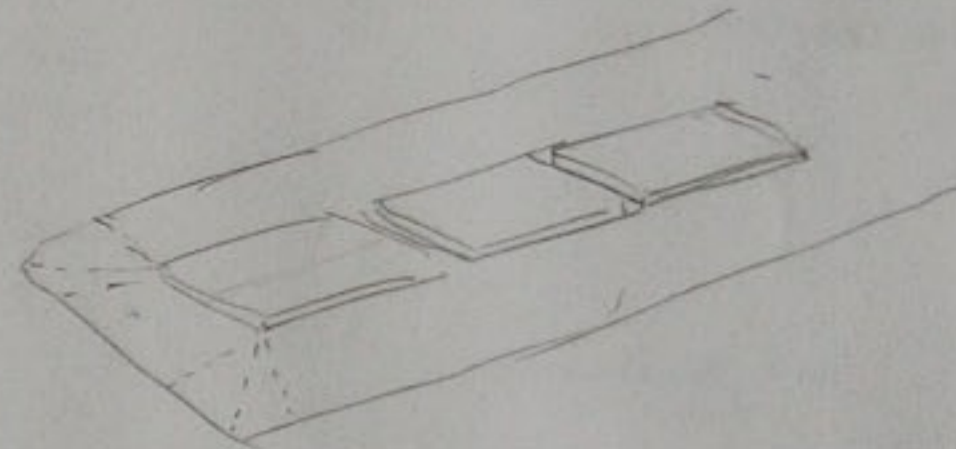

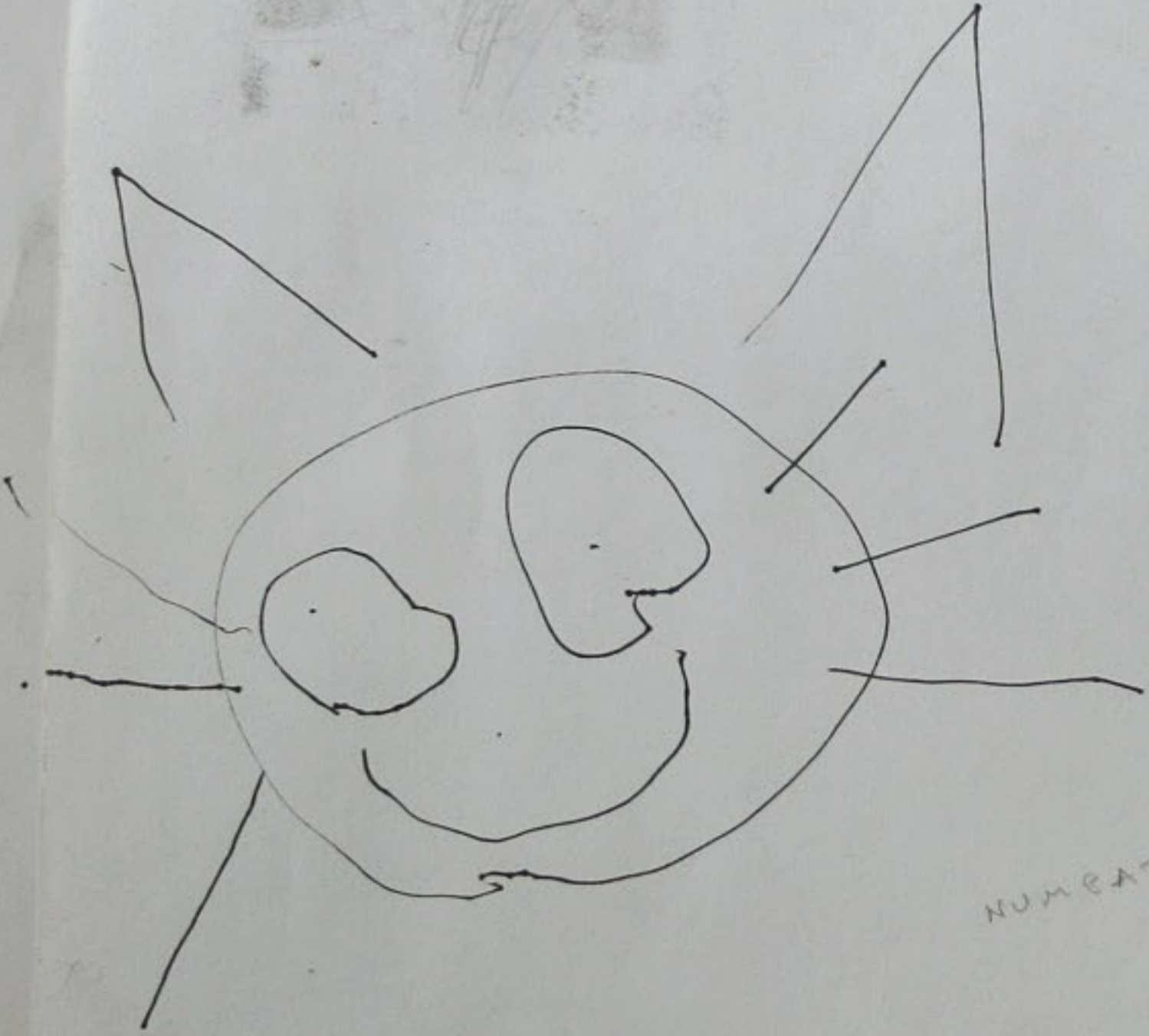
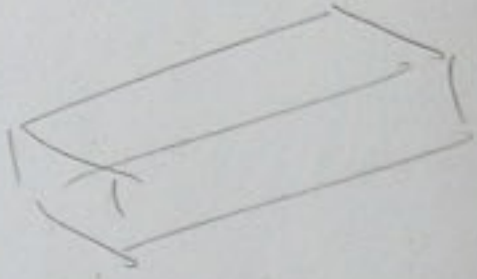
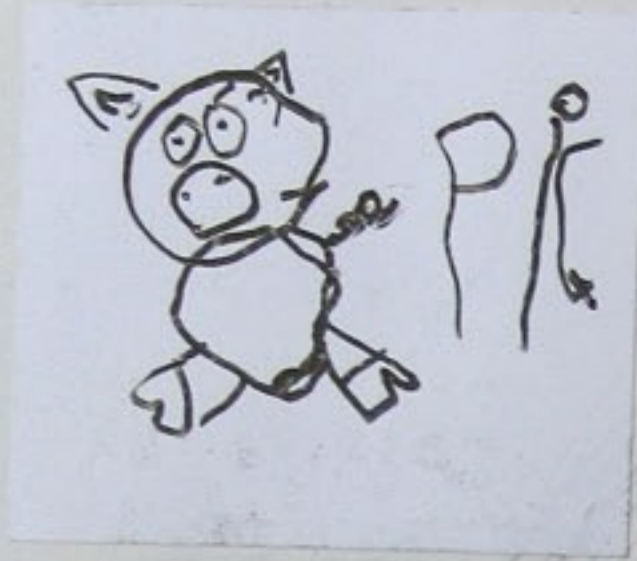

NUMBAT

NOTE FROM DOCTOR
FIRESTATION FOR STILLER POR HOUSE
VIDEO CAMERA FIX

COLORING W/ HANS
REFRIDGERATOR BOX
SHOW HIM VIDEO OF SELF

540 D1 ^{3001H} → 480 D1

AVI
-MUSIC CREDITS BLACK
-BAND SQUISH CIRCLES
MAKE LOOPS 30 SECS



HAPPY EASTER BUNNY!

FRIDAY 11th
3:35pm screen 3
STRANGER
A Burning Man Film
www.delinquentfilms.com

ER NIETFIELD
-8395
@MINDSPRING.COM
7990

752

6401 -MACHINE OIL (LUBA)
-CALL MACHINE SUPPLY
-CALL MACHINE SA-P
-EDGE FINDER
B27A
DUFORD BROS.
JIM HOOPER
REMOVE BACKLASH

SOLENDON

DUWALL ON 4TH
LYNN

MSC
800 645 7270

WDR KINSH
616 372 3270
TEFFFL-JR

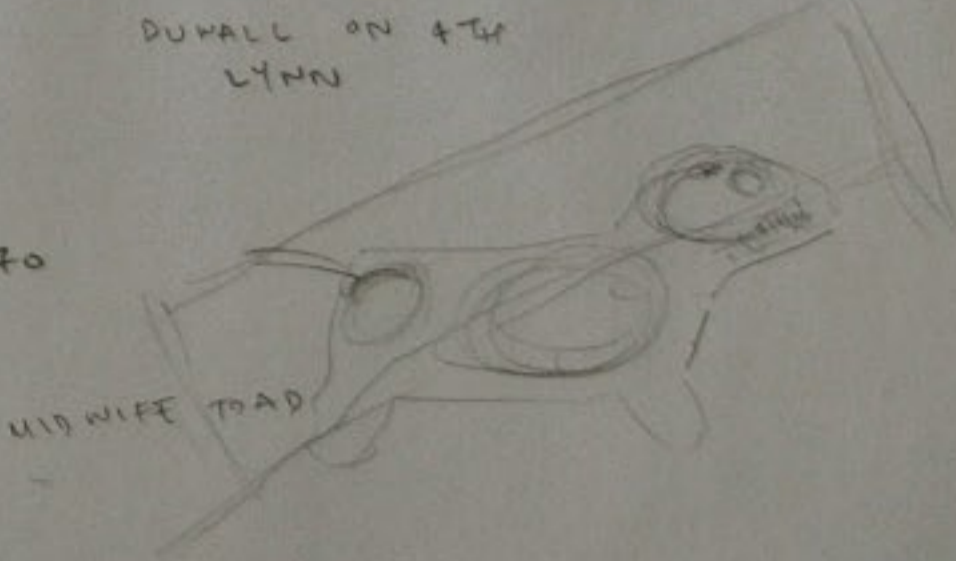

MIDWIFE TOAD

WOODS HEAD
EEL AIRBORNE
CRAB HATE

I ON BOAT
IT WHEN NO HOME ON EARTH → BOAT CRASHES
BOAT SINKS IN POOL → BABY GOES UNDER
MOTHER PLEADS W/FATHER TO JUMP & SAVE (SPLASH WATER)
FATHER INSTEAD DIVES IN
FATHER PLEADS WITH SON TO SWIM TO SURFACE
SON AGREES BUT FATHER IS OUT OF AIR
FATHER SAYS BOTH BY JUMPING FROM DIVING BOARD & SPLASHING WATER OUT OF POOL



HANS!

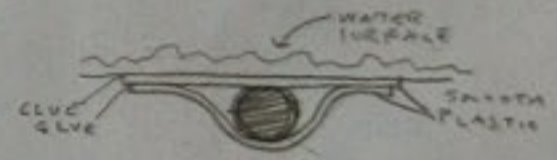

-790-6664
Perry 595-7482
FAX 591-6813

KURT ANDREIS
261-4112
CRACA



DR. 7 1470 2

THURSDAY
DOUG
11:30

WEE
SANDY IN
TODS

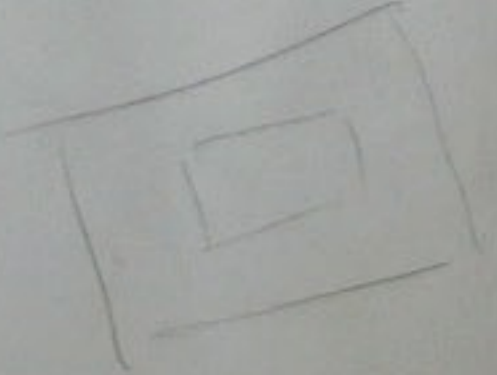
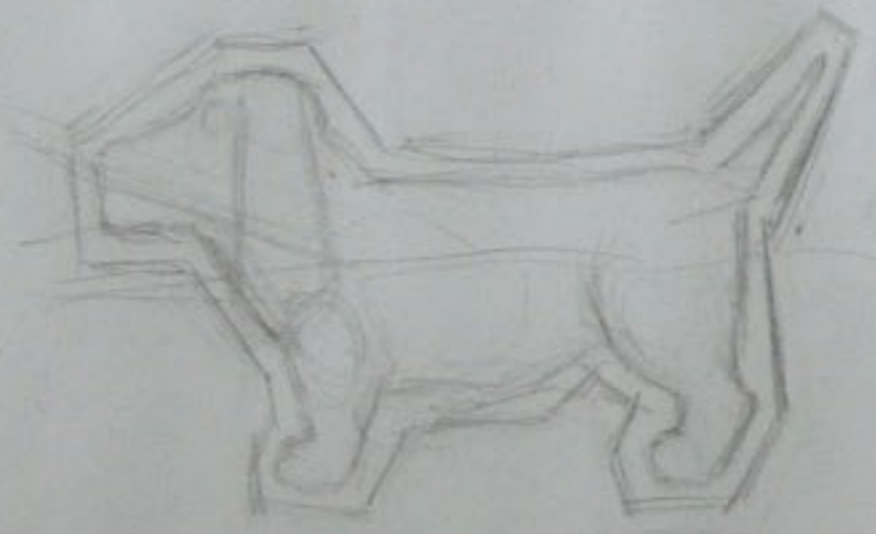

SHINY HANS



HA HA



APPY

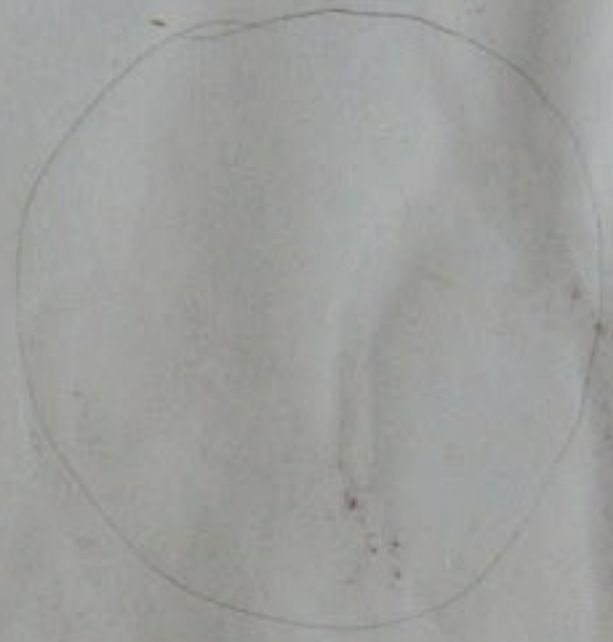

GO...
ORIGINALLY FROM 200133-200133-200133-200133-200133
PLANTIA TEL: 805200 FAX: 593-4-807366 Durban
Aui



411E



THURSDAY

No IMPULSE CONTROL

- LO-RID
- BARE
- SEA
- SEA
- RABBIT
- PANDA
- MAHUA

SEP 19A

ANIMAL FROM MAURU
MEXICAL ARCHITECTURE



PAUSE
JUNE 2

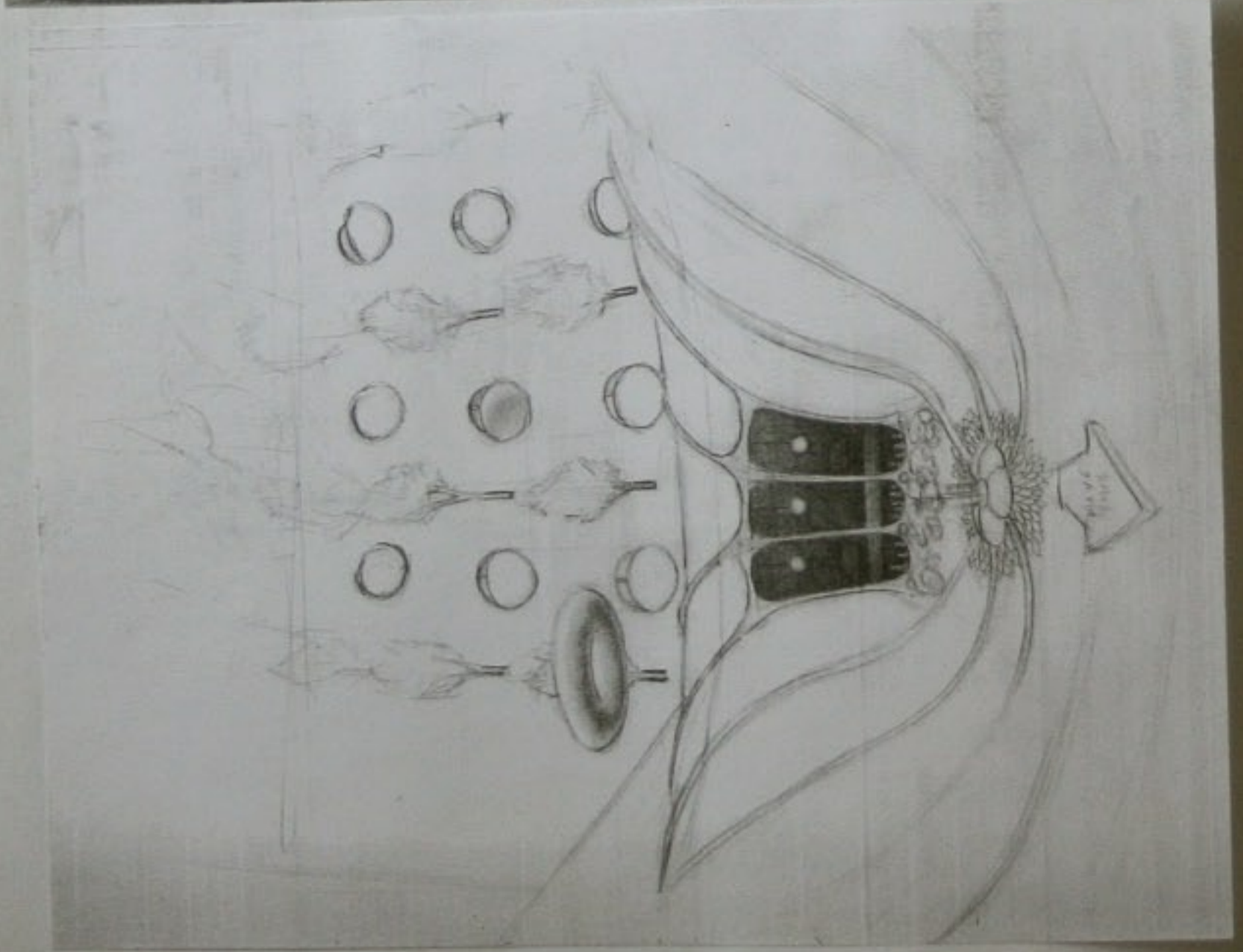
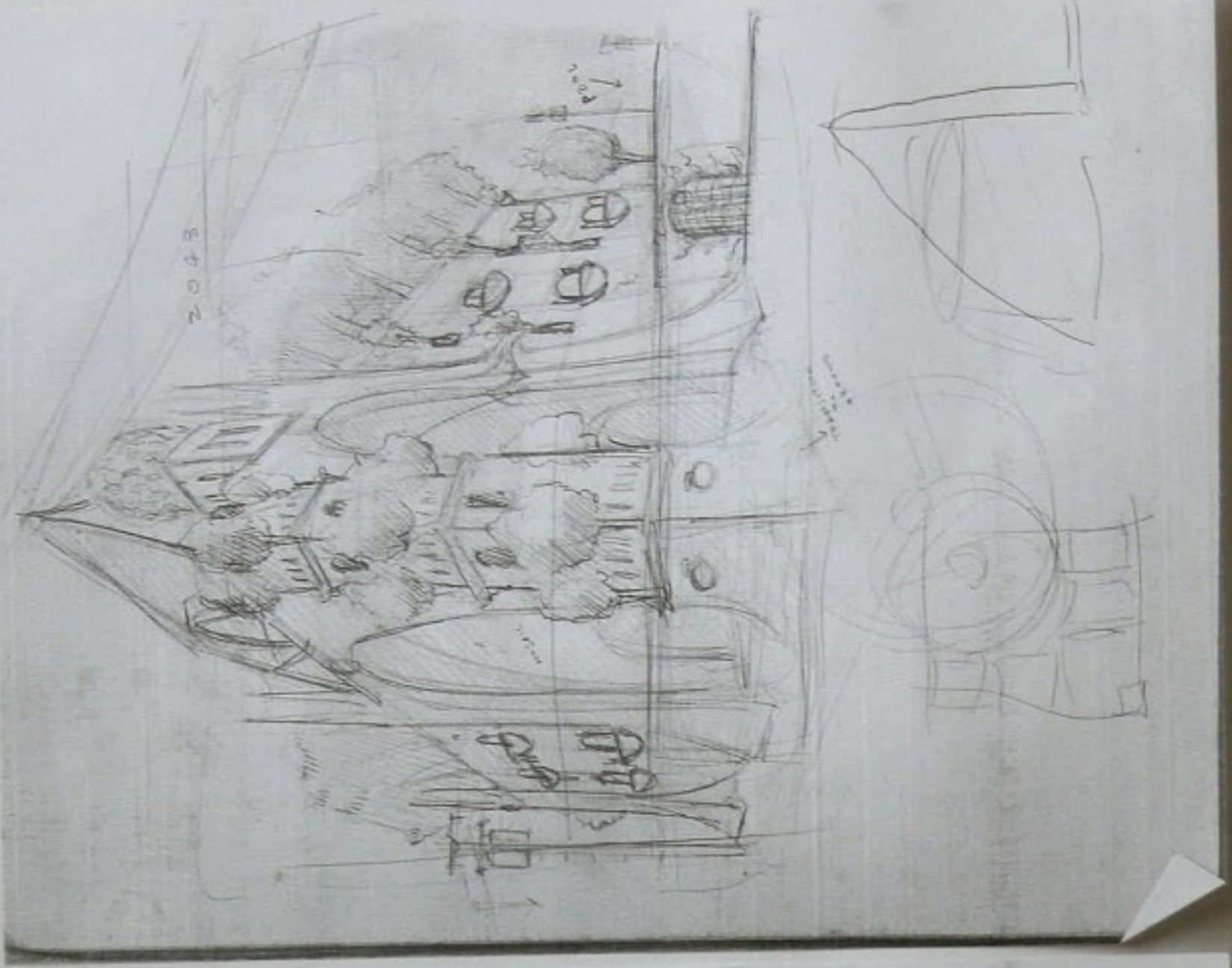



JULIA GREEN
ST. BERNARDS
ENOS WORTH
(WEST END)

SWIMNAC.COM
FTP: SWIMNAC.COM
USER: SWIMNAC
PASS: RELAY

METRO
PRESCHALL
860 7559

BETH
3-5

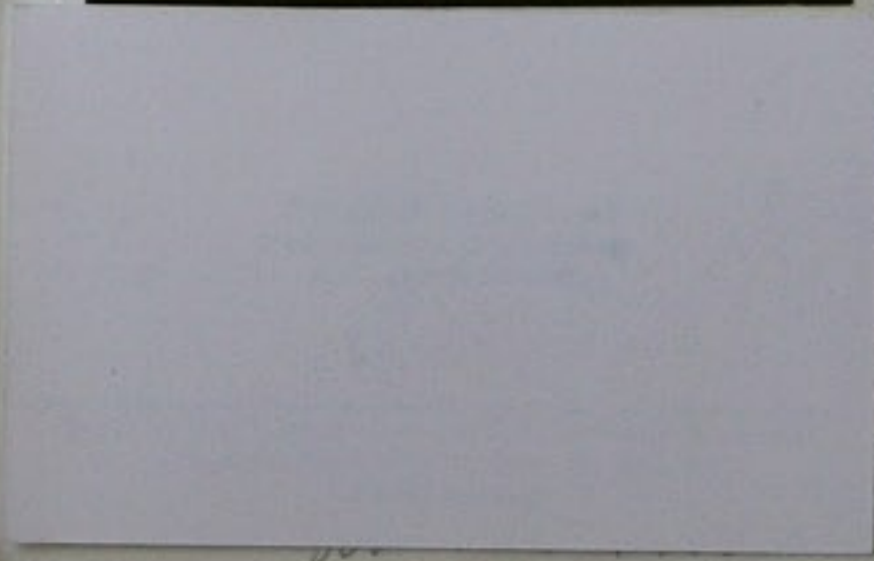

TUES
22
1:00

FUN
940505

050 2700

REPORT
(TIMES
(WEST))

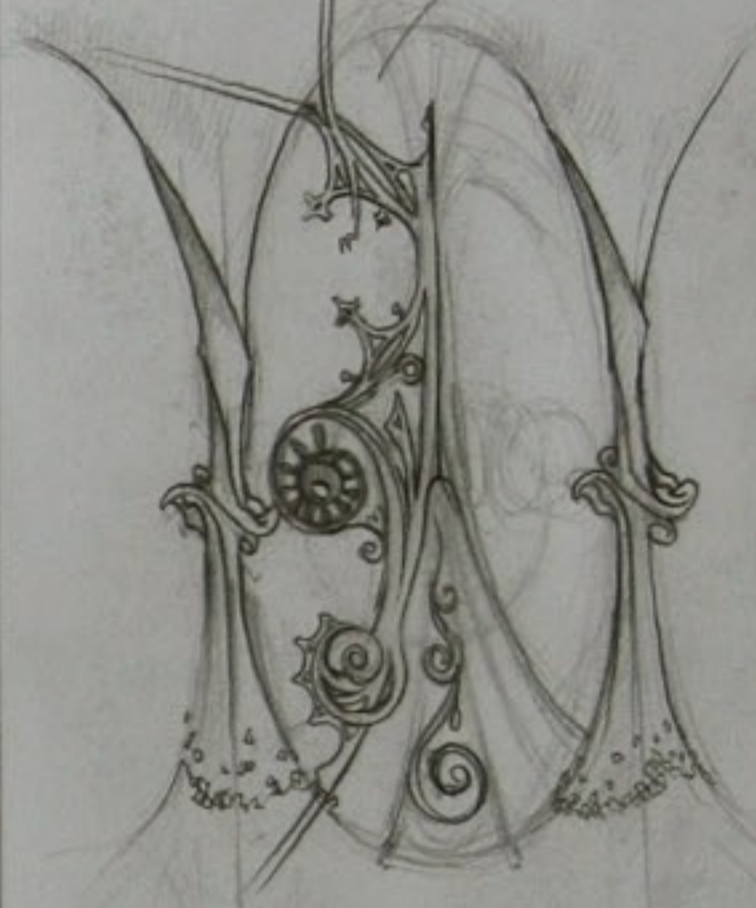

DO NOT CONSIDER ←
400



DUANE
KENT
03500

9711 WY-MING
9-+

31-849 7 2 72

GERMANY
AFRICA
INDIA
HOLLAND
FRANCE
CHINA
RUSSIA
MEXICO

OBVD

WR EX PMS

SUCH A PRETTY BIRD

LITTLE SHOT

ADAM'S
APPLE

PEACE
PLENTY
VICTORY
MIRTH
HONOR
WIT
SENTIMENT
WHISKY
MORALE
CHOCOLATE

MISLETOE





NOTE: USE TRACER

655 →
96
AWY 96

CROSS RR
① @ LIGHT
330
423 S. MARK LN ST.
ADM. BLDG.

969.69506



JUN 80 TRON



BRIAN
71756

1513
LYNDEN
3527711

500
8647

COST OUT

CLOUD TRUMP
GREEN TO BLUE
CITY - FRONT COVER
BEPEME FLAG
BIGGER "WORLD LIKE..."
V LOWER CASE
CK R X -TOP

COME X 20 SEC 4:00
ADD

LEAFAMERICA.COM

BF I Q U H
↑
STUA
LKE
PULLING
OUT

\$325
NO V 157
80 MONTHS
5

NO



VACANT LOT
FLOWERS

SIDEWALK

APARTMENT EXT.

APT

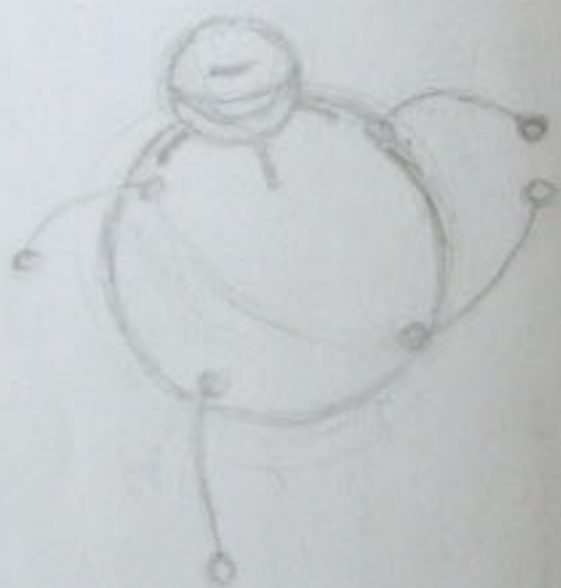

- 1) CROSS (ADDED COST 10.00)
- 2) LOT (GREAT LOT)
- 3) SHOWS OUT FLOWERS
- 4) SHOWS OUT BIRDS, RABBITS, SQUIRREL
- 5) RABBIT WHISTLES (LIVES IN TE)
- 6) ARRIVES AT APT
- 7) CLIMBS STAIRS
- 8) PICKS UP & ENTER
- 9) FORCES GET OUT (HE THROWS ON DOOR & LEAVES)
- 10) GOES TO KITCHEN, WEARS APRON, TAKES OUT CANS
- 11) CHAIRMAN COMES OUT & MAKES MEAN SHE EATS
- 12) BLUTE BOYS WEIRD CUM @ TOWN SHOP
- 13) WM. BACKS GIRL INTO BED
- 14) ~~FRMS~~ FRMS WHIPS ON GIRLS FEET
- 15) WHIPS SPIN & SHE MOVES AROUND ROOM
- 16) TIES SWEETS TO WAIST & LOWERS FEEL WINDOW
- 17) LEAVES APT, SEE BLUTE & BOYS DOOR
- 18) BLUTE SHOWS WM & ALL THAT'S LEFT IS HAT
- 19) GIRL DROPS TO GRASS

KRISTY HEJAN
157 2411

10 3
100 10
100 5
52
280

COME WHAT MAY

MICHAEL@
FIDELITYCENTRAL.COM

TRY NON-DETEM

R+B
WOOLSET
534 0220

FRONTIER
300
\$1.35

1 DAY
2 DAYS
\$2.25 LABEL
\$675 FOR 200 CDS

MICHAEL
SPURGER
FIDELITY
OFFSET

244-9200

916

TWIN ELMs
140 →

COURT MAIL 20TH
MICHELLE

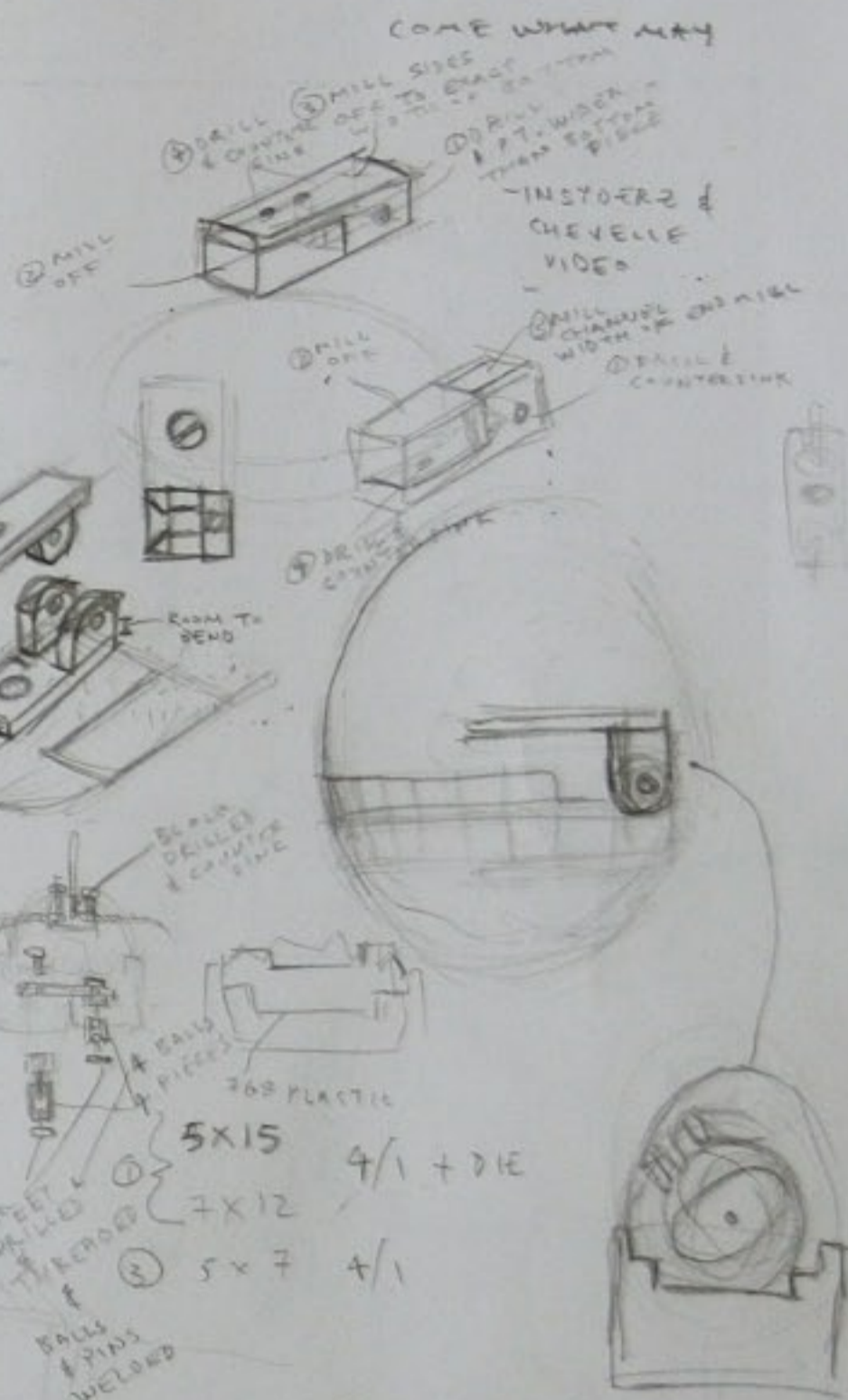

5X15 4/1 + DIE
7X12
5X7 +/1



923.07

A
FRI

MAN'S BED AT
CENTER OF
CITY - IN
CITY
WAY THROUGH

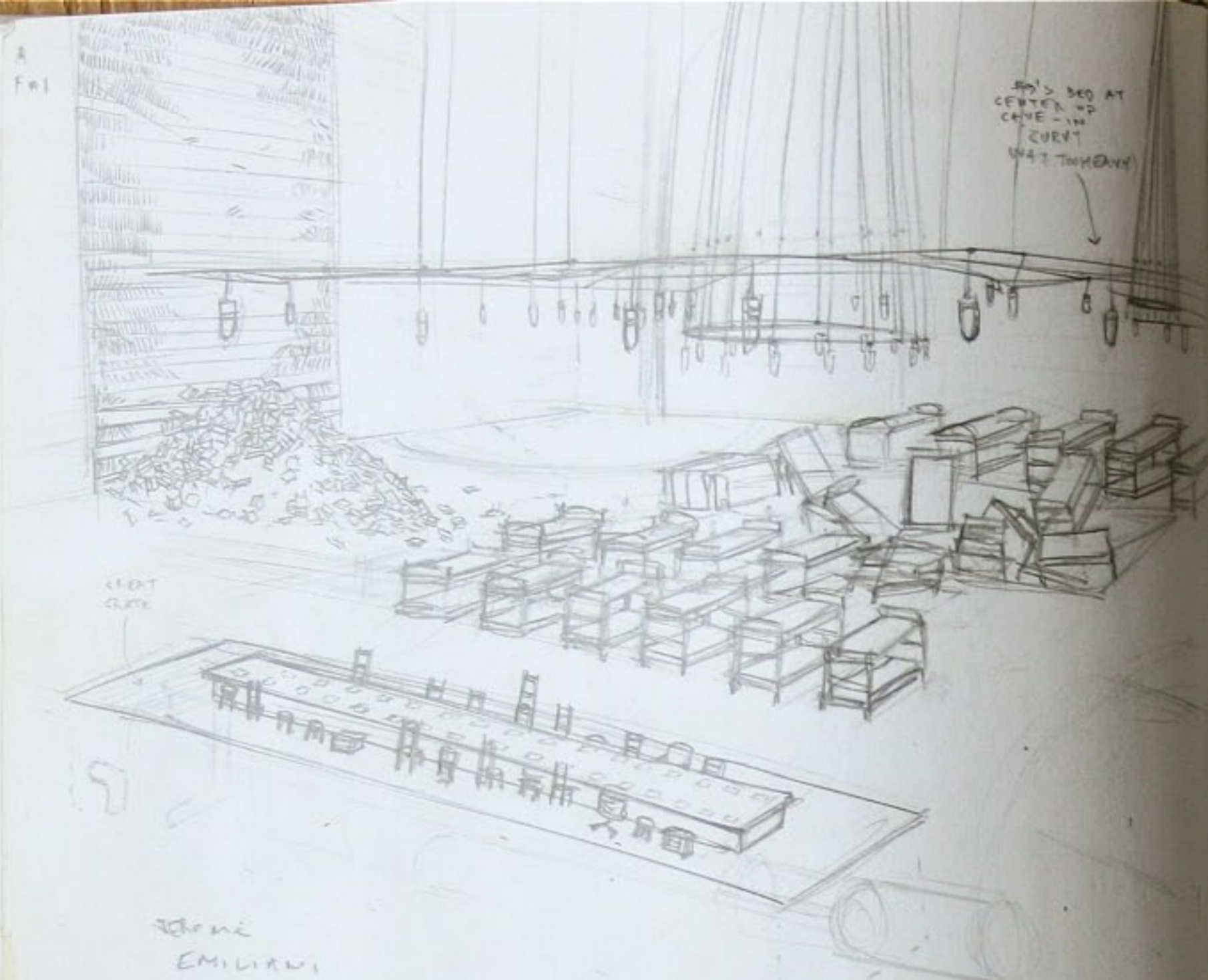

EXIT
CLOSE

HOME
EMILIANI

LITTLE BOYS & LITTLE GIRLS ROOM

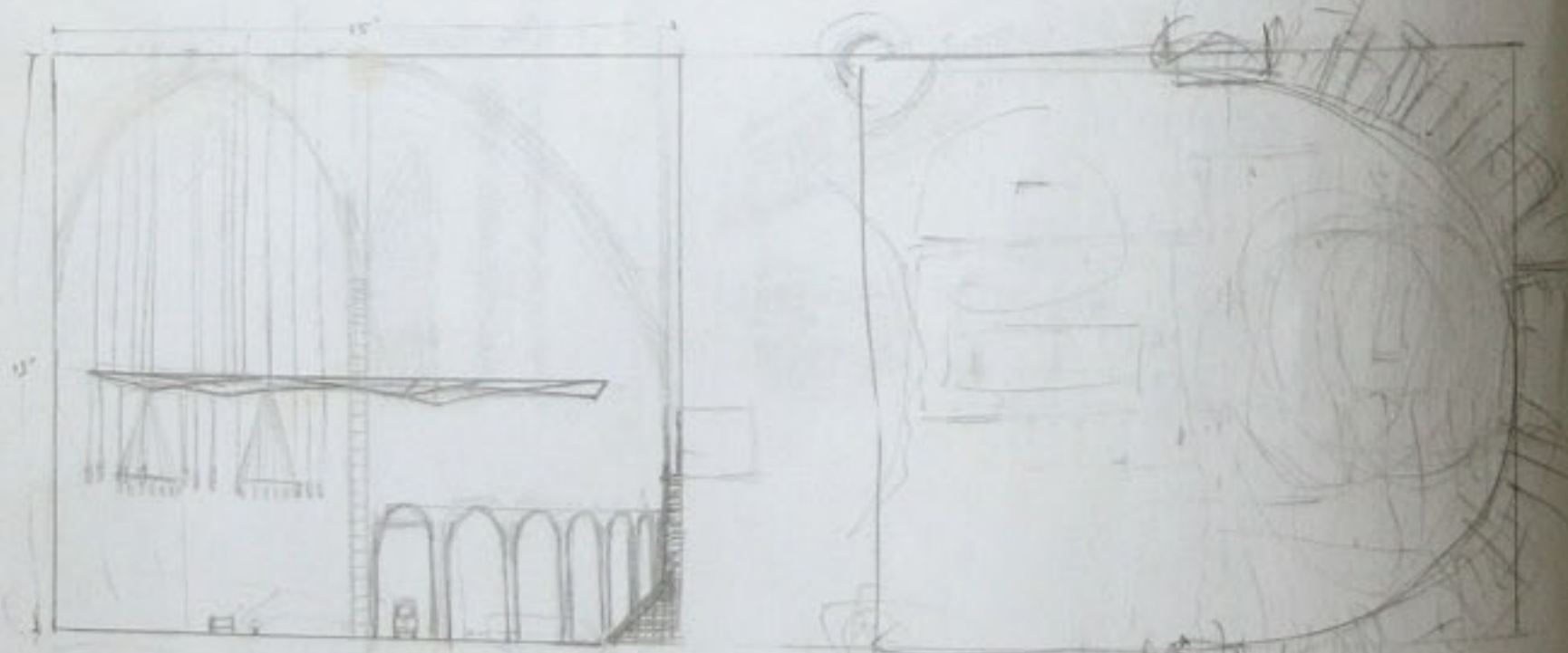

SAUCTUARIES

- A BATHROOM - MISS HAIR
- E LIBRARY - NIGHT
- C POOL WATER CRASH (MECHANIC)
- B TABLE (FOOD) FIRE - CURRY
- P BEDS - HAIR
- F CEILING - ST. TOP
- G PLAY GROUND - BEDDER
- H UNDER FLOOR EARTH - MAPPER
- J CHAPEL WIND - SPIKE

TOWER
D'COMPLEX

- 7-UP
- 14-UP
- 21-UP
- 28-UP - SOCIAL INTEREST

REALITY OF ENVIRONMENT
 - ROTTEN FOOD STUCK IN FOOD MACHINE
 - FOOD MACHINE WORKS SPORADICALLY
 - ALGAE SHELS BY THE POOL
 - WASH CLOTHES IN EITHER BATHROOM OR POOL

BLACKBUSTER



SPARKS
RICE'S OF
DR. B. BEASLEY

HOW MUCH IS THAT DOGGIE IN THE WINDOW

present?
- exit sign over a blocked exit



HORSEBUCKET

SUBWAY 3560460

20 x 1.75

- AD HOUSE
- M-TOWN GRAPHICS
- NASHVILLE SCENE
- PERRY



- | | |
|-------------|-----------------|
| VIDEO | DESIGN |
| - CASH COW | - DECISORS |
| - INTERRE | - PERS. PAIR |
| - CHEVELLE | - SIXTYE SINGLE |
| - LEVIE | - ETHNIC. B-T |
| - OVO (IAS) | - LP CD SINGLE |
| - BANG | |
| - DOL PINTS | |

ILLUSTR
- MARK



3:00
 571 6857
 NICK BARRE
 101 WINNERS CIRCLE

CINDY SWAN
 72307
 SENIE - MR
 316 1367
 AMANDA CASHER
 NATIONAL ASSOC.
 OF SELF-EMPLOYED
 WOMEN
 WWW.NASE.ORG
 1800 232 6273

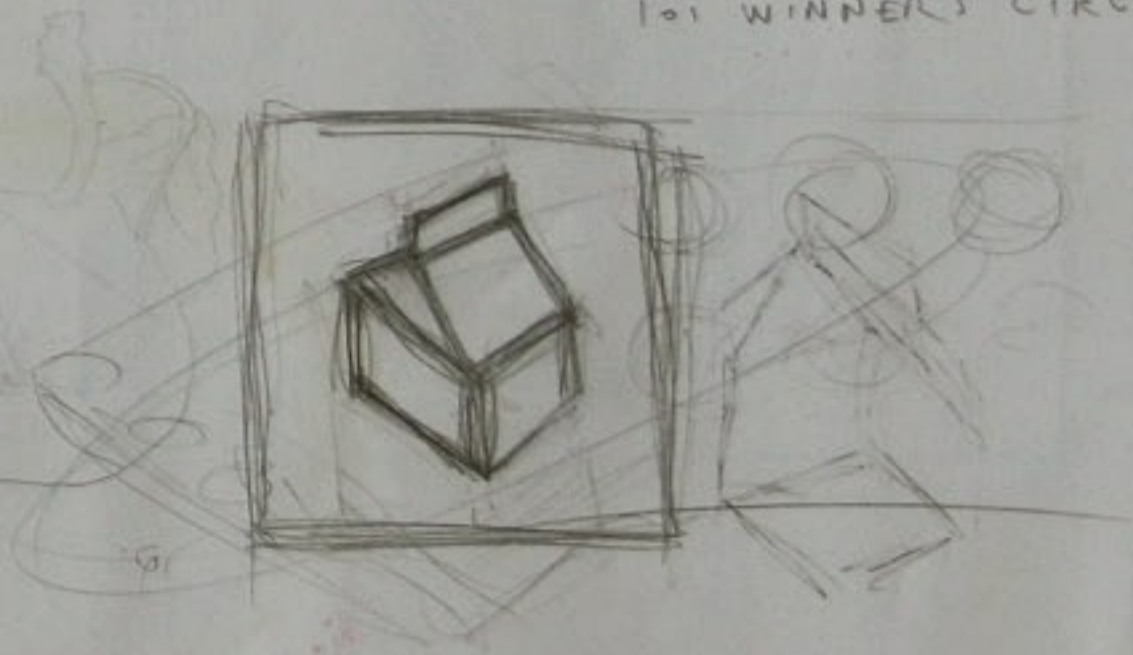

THE ANIMATED PHOTO STILLS BLUR THE

PROVIDE SUBTLE SHARP EDGE

SUBTLED ANIMATED EFFECTS

PHILONS MOVING

LONG
OSTER

- STEVE SMITH
- MITCH MAUN
- MARION GUGLIASSI
- ANGELA BROWN

SUS



ZEEPER & LIRVIN



ZEEPER REMEMBERS HIS MUMMY & DADDY BUT NEVER WHY HE IS LIVED

GRUSCOOTS .ORG

DLVE NILE
2ND
(1973)

IRREBALL BE
COMPLEXITY

BUNTING
THES @ 3 PM

AIR OF SIDES

KRAKI SASH

KNOW FOR MORE HILL CLIMB
-EYES

SIRESSGOTS OF



- NEED CATALOGUE FOR
CLOTHING



ANASTASIS -
DESCENT
INTO HELL

SIMPENCEY
38TH INSTALLED

SOUL JAHZ

ADORE
BURIAL TO CASHMERE

EVERYONE

N
S
D
X
H
S
H
N



GEMWADY
SPIRIT
UNREMEMBERED

JEFF

726
8754
THE LAST
CASTLE

M-N

FRIDAY

WINTERFREST

85.0
89.0
84.0
85.0
87.0

MORPHEUS .COM
DRIVES
MUSICCITY.COM

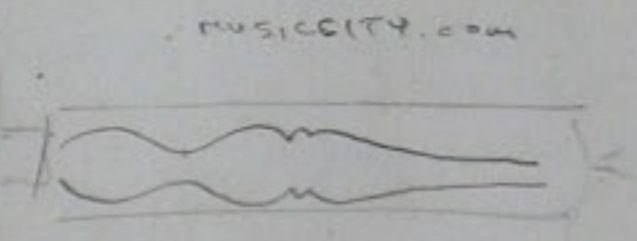

- DUAL ACCOUNT "RICHTER"
- HIDE EMPLOY.
- NEW FRONT PAGE
- NEW ENTRY ID HISTORY
- HIDE FILM SECTION
- HIDE



SKETCHBOOK
AMY B

WIRE DOWEL FINE
PIRE SECTION EXTRA
AMY D B C B C A
MEG C D C B C B
PANELA B A A B A

CALL SOB LEGS
- FILM IS ON WHEEL
- GETTING SOB
TO PAY FOR
FILM COSTS
WHEEL SERVICE
IS FINISHED
- WHAT SOB
SOB NEED TO
BRING FARM
TURT HEADS
IN FOR SKETCH
- WHAT IS NEEDED
TO USE MODEL
HAVERS?

DOWEL - B
FOAM - C
BRISTAL - B
FINE A - B
WIRE - A
OTHER - F

BRICK
B

ENTRANCE BLVD → MALL RT
MALL RT STATION
370 MALL RT STATION RD
SUITE 103

MARLEI DAUGHERTY
W 778 9918
C 307 4665
HISTORY
- NEWNESS
POWER OF MUSIC IMPACT

E MARLEI@DOXOLOGYRECORDS.COM

WED 2-4

ED-GNE.COM

LAUNCH - JAN 1
DEC 15

RELEVANT
RELEVANCE

WWW.ALRT.DE

SEND
LINKS
E-G MEDIA.COM
ECKO.COM

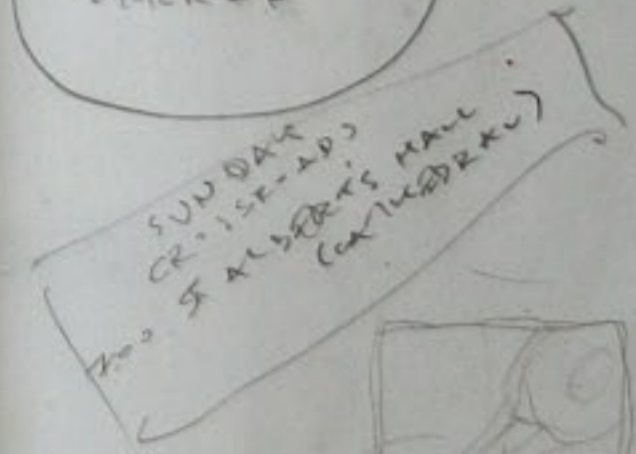
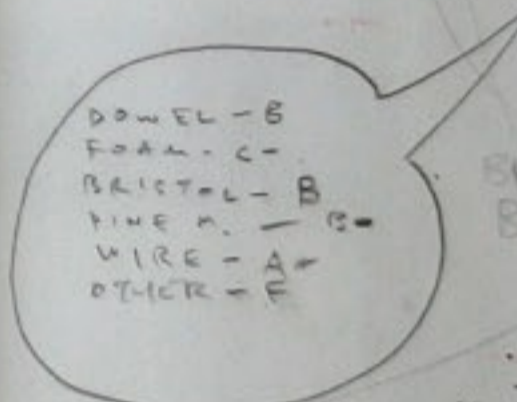

26.66 517
MAY 1994

LINE OF EVOLUTION
BY JONATHAN WELLS

JAN 17
CASTLE ROCK 7PM-9PM

17:30 → 21:00

925.5 492A

WILLIS ALLEN RANBYET

EMMETT MILLER

DELIVERY
CHESLEY
CLAYTON
297 4200

RUFUS

HOUND DOGS

DSANGO
HEINHART
HOT CLUB OF FRANCE

FONT IS BLURRY

MARK

ANIMATED SLACKERS

WAKING LIFE

SAN DIEGO BUSINESSES



DEC 3.

TR 340002
SIMPLE

SINGER OF
LUV LOMBARDO'S
SWEET HEARTS
ON PARADE 377 1252 FAX

ADULT CLEVELAND
TERRY DOUGLAS

BUDDY GREENE
377 1251

TIM
828 2814

ROBERT MICHAEL
THUNDER ROAD



STEVE@STUDIO
794 9782

DILLENS CHRISTMAS FESTIVAL
DEC 8TH @ 3PM
~~AT THE CLUB OF CHRIST~~
THE FACTORY

-ART MATERIALS
MO. RILEY@JUNO.COM

UNIVERSITY OF MICHIGAN
"MIRACLE... "EDDIE"
"CROW"

DECK THE HALLS → RESET @ EACH LINE

RUFUS ("RED HEAD")
GREENGRASS
GREENE BUDDY
COULD BE WORSE
VIN CETTES



CATALOGUE
FOLKWAYS RECORDS ARCHIVE
CENTER FOR FOLK LIFE PROGRAMS &
CULTURAL STUDIES
955 L'ENFANT PLAZA, SW,
SUITE 2600
WASHINGTON, DC 20560
202 237 3262

1000
FINISH
PIC
MERRY CHRISTMAS FROM SQUINT
(LIST ARTIST)
COVER IS SKETCH D-PRINTING

TIM O'BRIEN

"SALES CONFERENCE PREPARATION" -ART



MAKE 'EM SQUINT

"ANYONE HERE WANT TO
TRY MY CABBAGE"
MAGGIE
JONES

NEWS

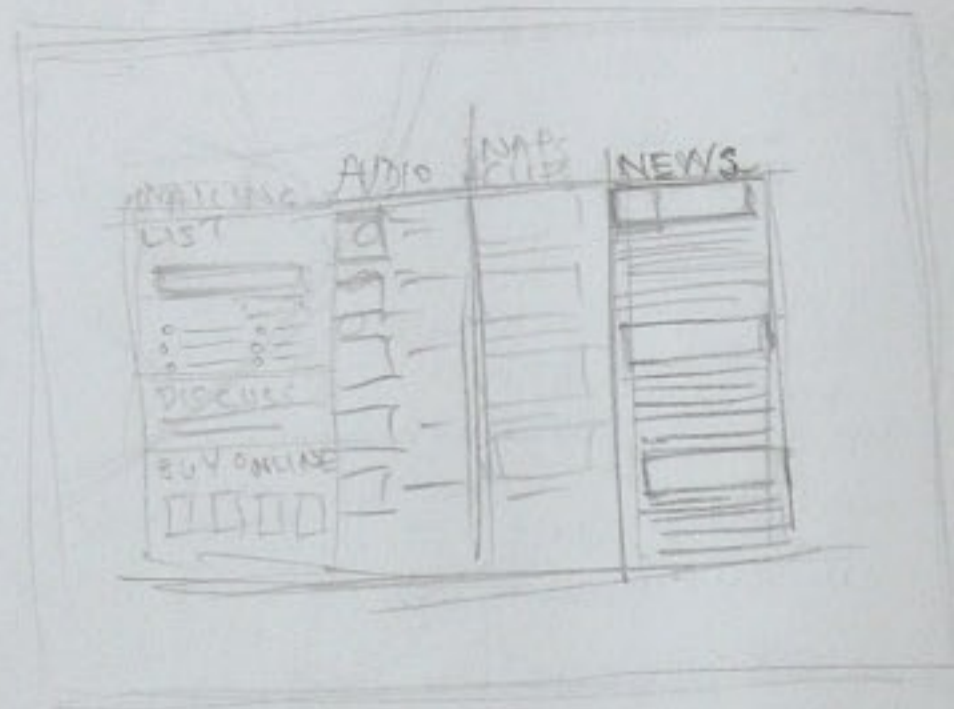

FACE'E M
SQUINT

101,000
381,000

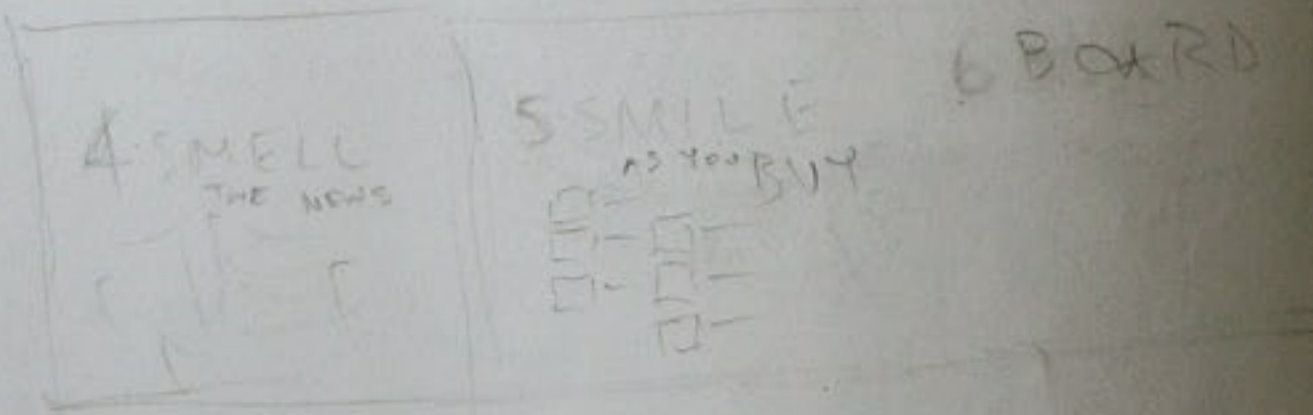

MANU
CHAO
...PE-MIMA
ESTACION...
EXPERANZA

AMERICASPRINTER.COM

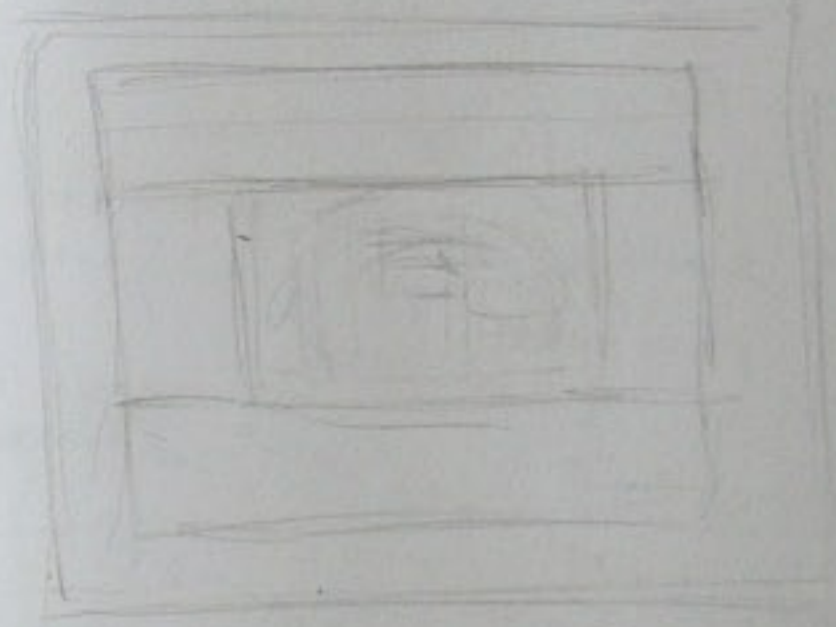

MORE UNDER CONSTRUCTION

NEWS #0 #2

- POTS & PANS
- PUZZLE BOOKS
- DIRECTIONS TO LA JOLLA

*5101

HEADING SOUTH

118

- ③ TAMPA
- ② DEVONSHIRE
- ④ MERVIN
- ① HIAWATHA
- 3RD HOUSE IN ⑤

THOMAS
SULLY
1782-1872
THE TORN MAT

READING



R

No 10

RH TANDY

FORWARD R. GARIS

EYES CLOSER
MOUTH MORE LIKE SKETCH

AKA ABOVE BUDDY
INCOFF-RATE LABEL

30 DIFFERENT EYES

LIVE-PROOF FOREST

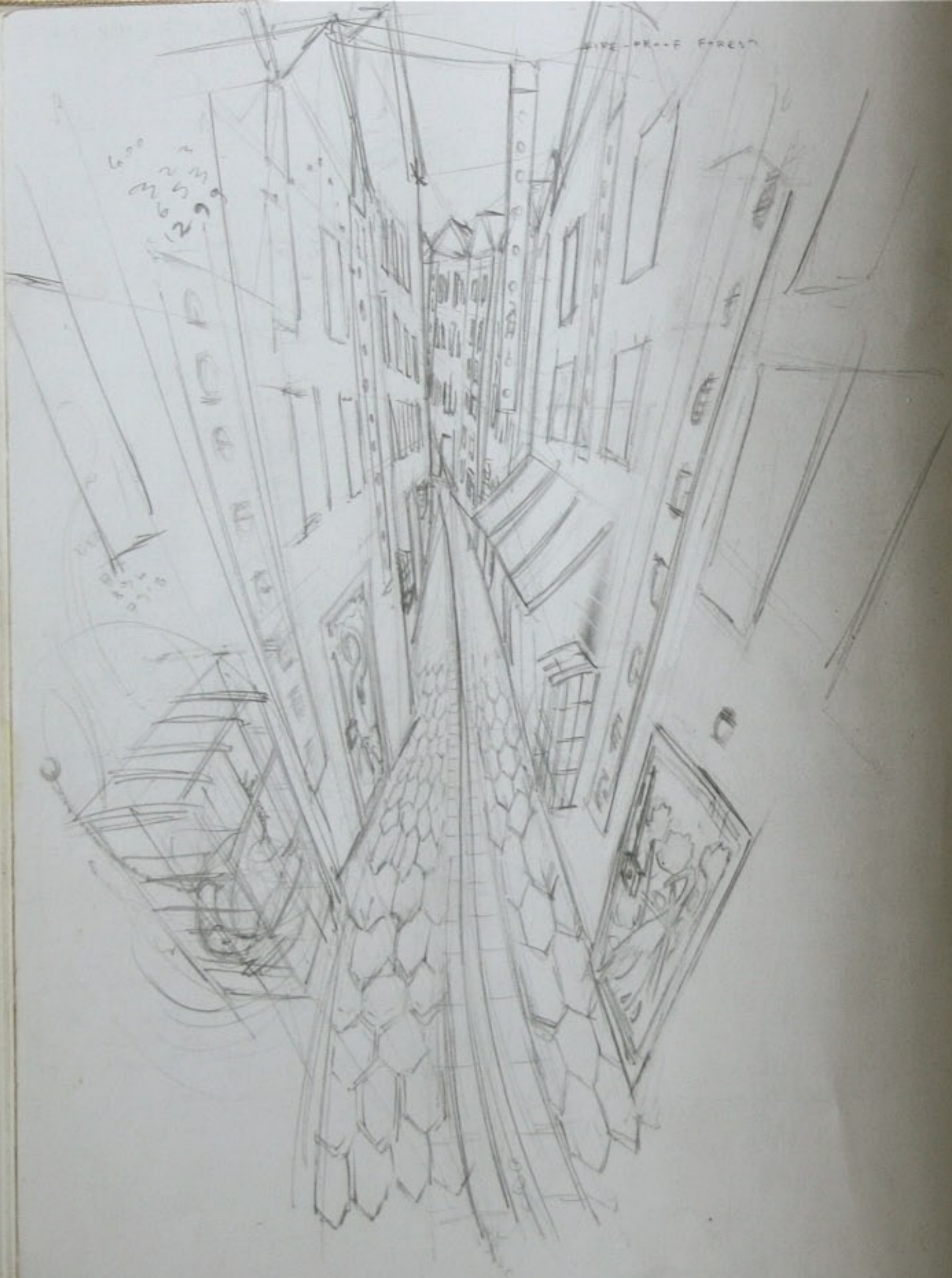

DESIGN REFERENCE
DESIGN VS. REAL LIFE REFERENCE
PROPORTIONS

SOFT TANGIBLE FORMS
SIMPLICITY OF
STRUCTURE
RHYTHMIC VISUAL FORM

SPACE

LAGER
FLATING BRIDGE
TOWER
BRIM 20' x 11' 1/2"

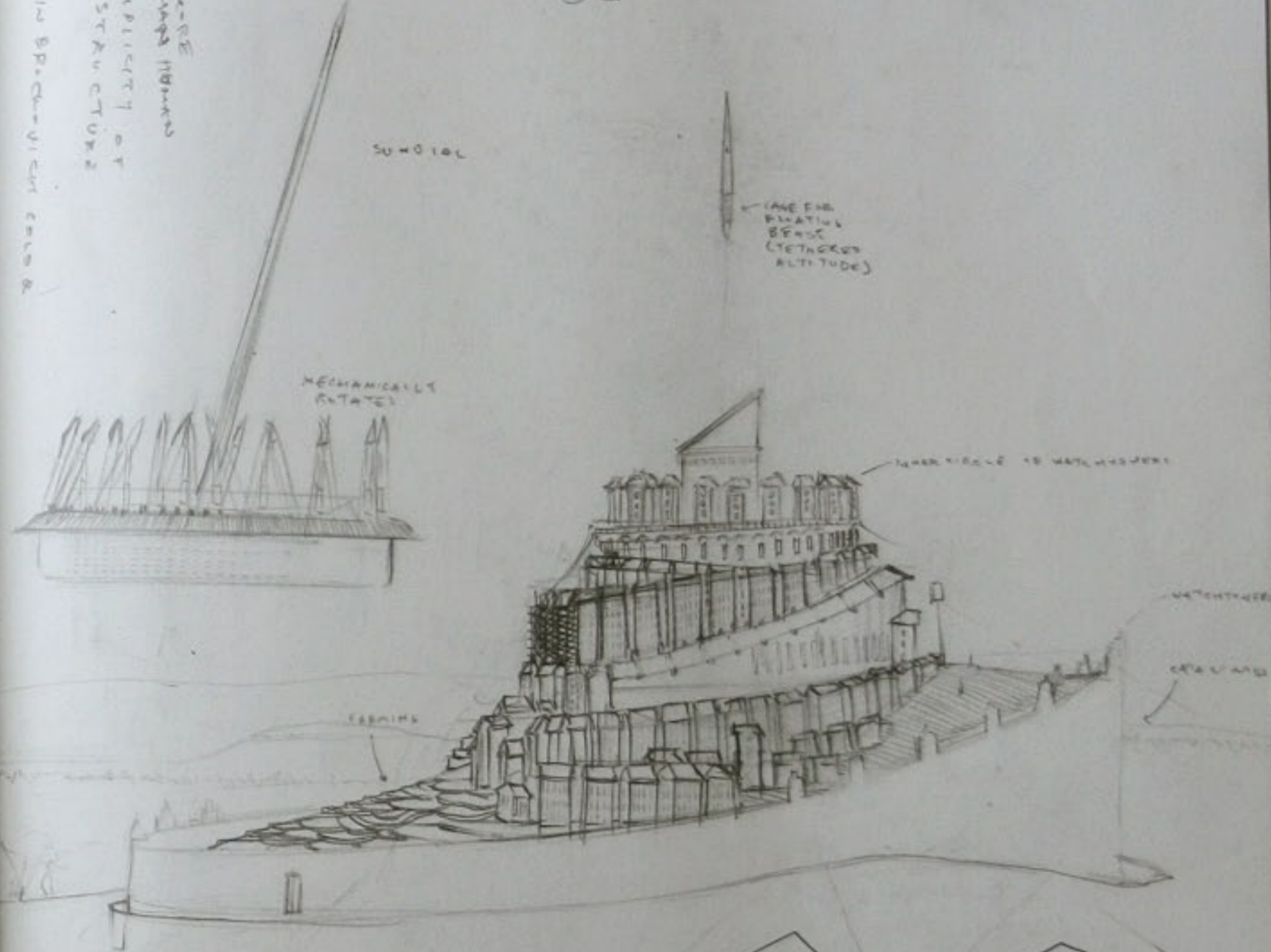

MUSEUM

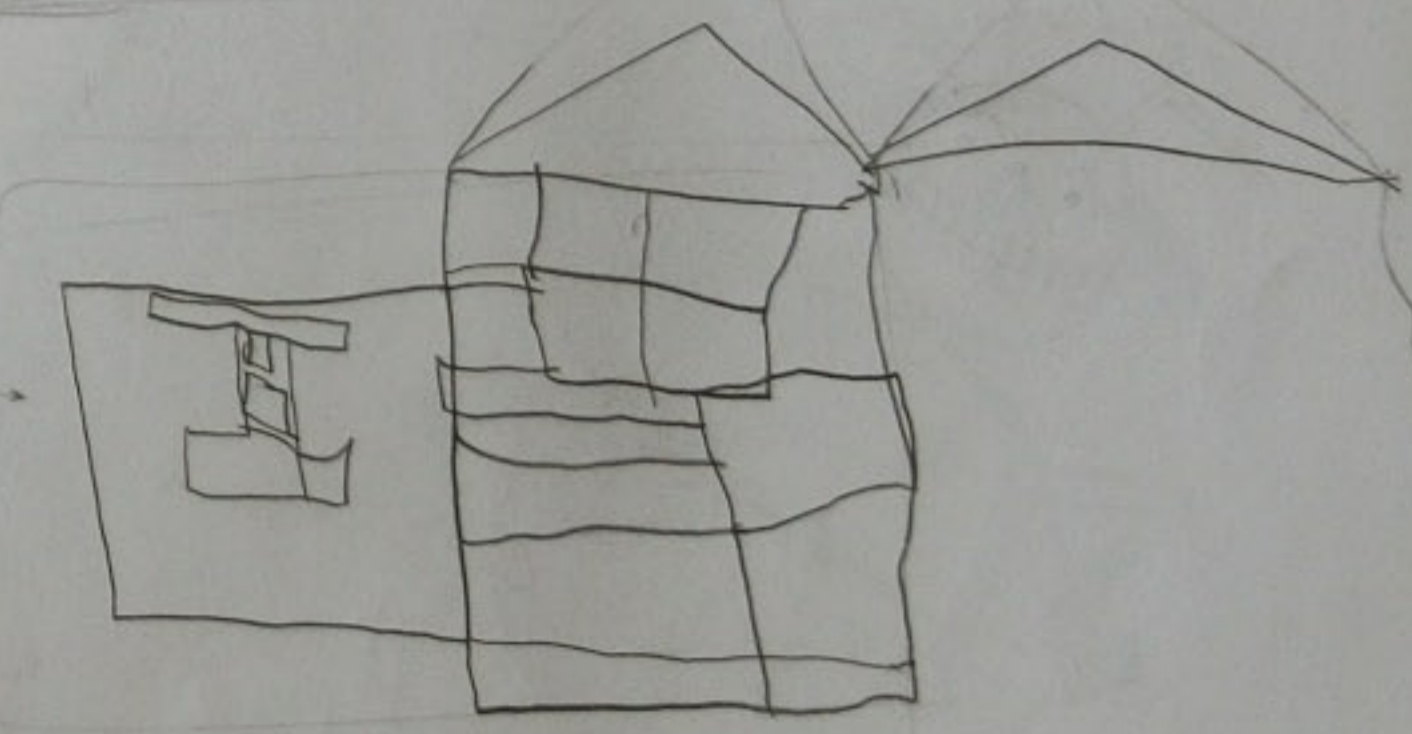

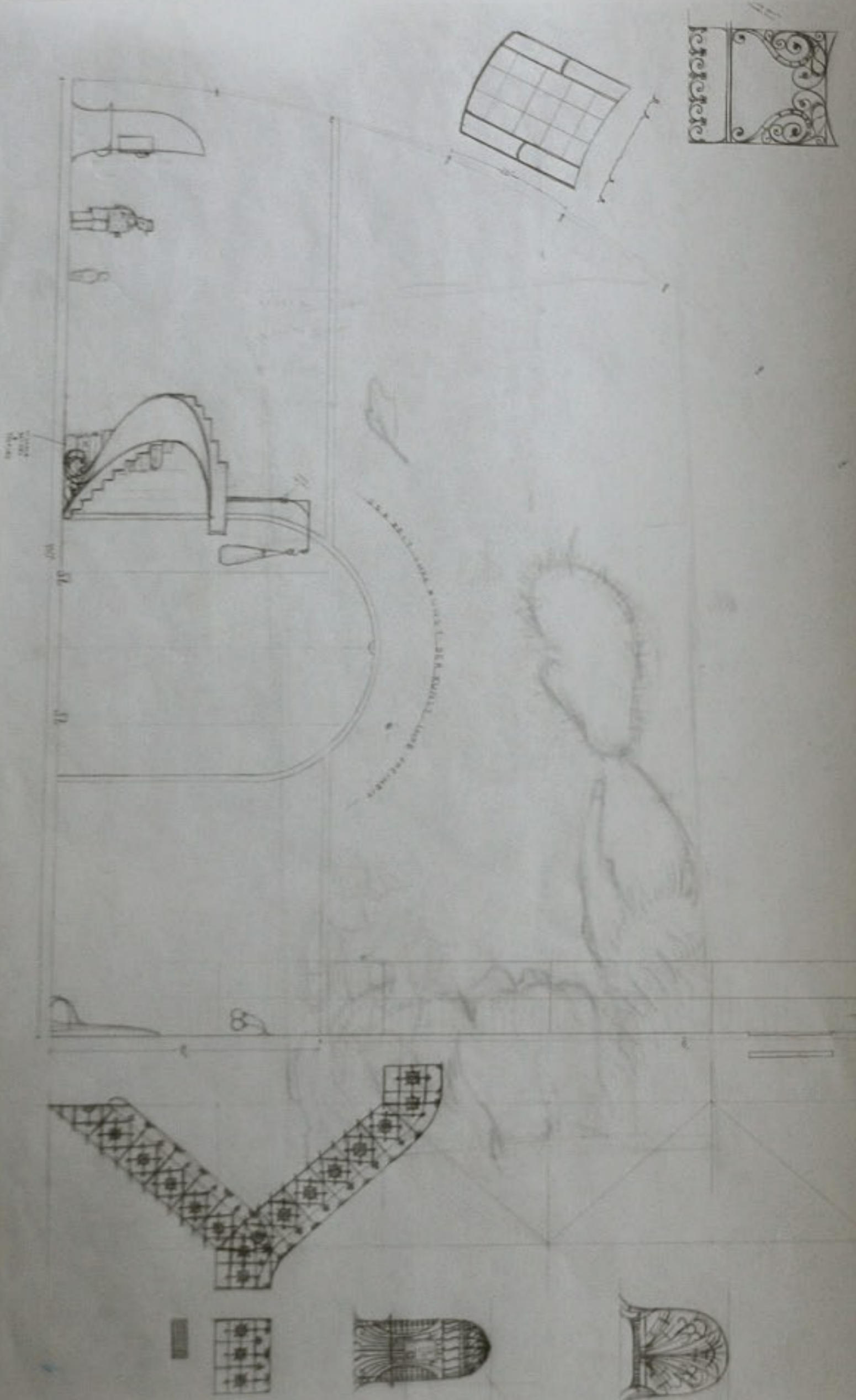

LAUREN CELL
2b-31A+



BLUE PLANET (DISCOVERY)

SPEED UP NPT. ORG

VITAMINS

MENU

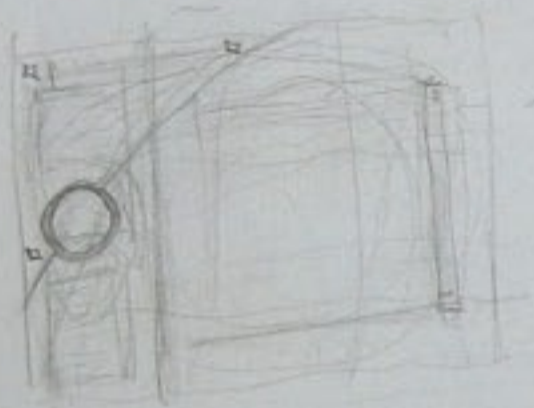

-CHANGE COLORED IN BC

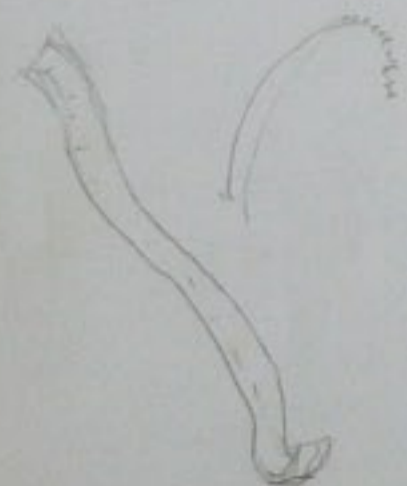

HARRICA KEYCHAINS

LEXANS DIGITAL SCROLLING VS. FRAMES



OFFICE

How do we model today?

ORIGUMMY

ST. RE SHEEP P-RTFOLI

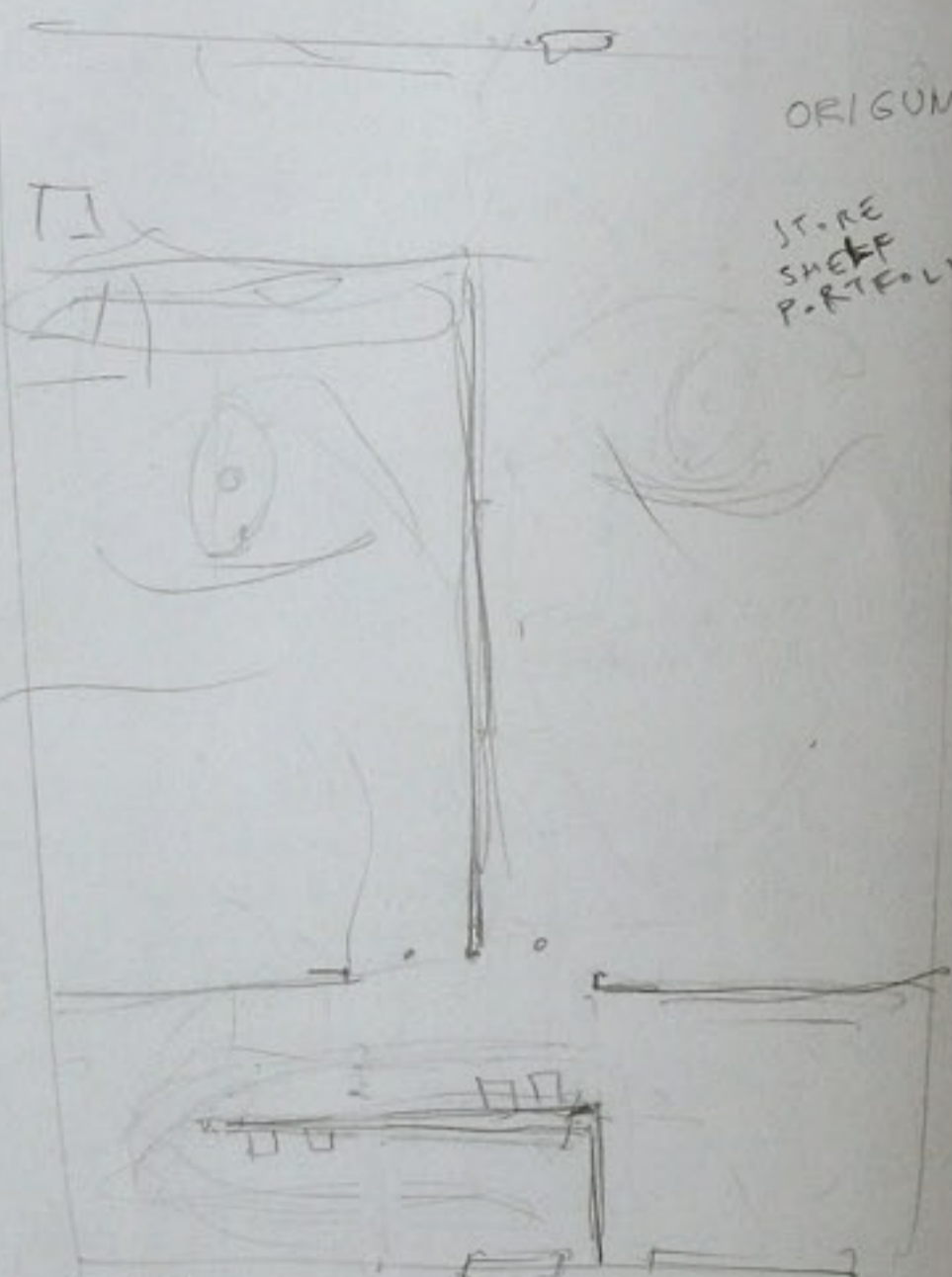

TRAFFIC COUNTER

- CHRISTIAN
- EMI - SPARROW
- REFRONT
- SIM HANCOCK
- GOTEE
- STEVE THOMAS (RELIAMP)
- INPOP (NEWSBOYS VIDEO WKW)



MICHAEL WILSON



Flat Rate \$ 39.70
 Install 1st line 58.50

800
 661
 3716 JAMIE
 X16711

Document Storage
 615 221 0055
 321 1601

PERMISS GREYER

\$48.20 (w/TAX)
 53.00
 NEW #
 (218 6789)

DSL 50.00

75.00 with complete choice

22nd

NO IP → per mo total 140. + Tax %
 IP # 40

X AYAMING
 X 12211

Cable \$90 your made \$95. renty from Comcast

Install 99.95
 244-7462

Jason Bannell X 1524

ASK ABOUT OVERFLOW PARKING

KINDER CARTON
 INCLUSION
 CINDY REAGAN



A HUM SUX

NONO THE SHY CLOWN

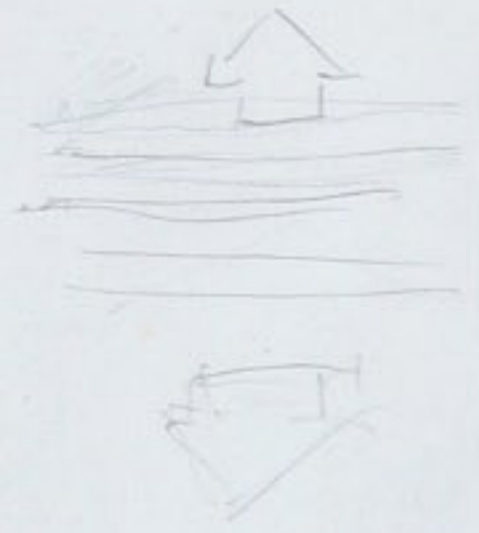

SHOW ALL SUBTEXT

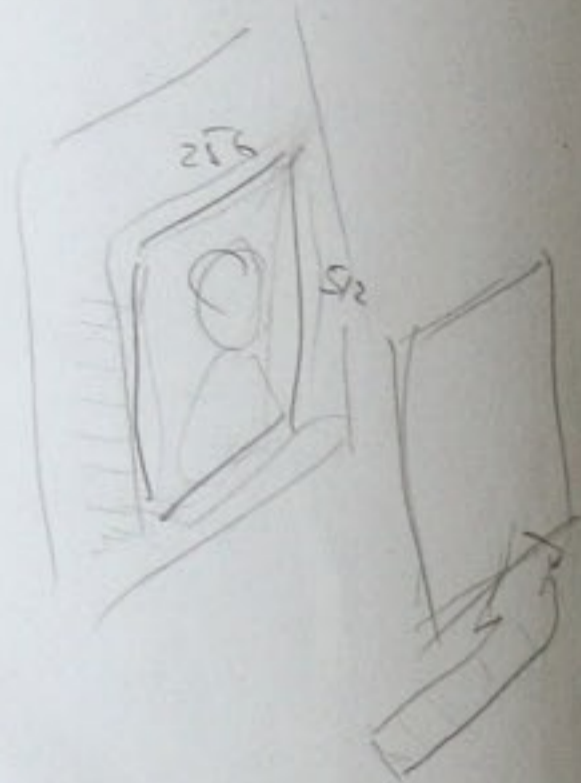

WAITING



BEEDER HAS DREAMS

1660

CALIFORNIA GENERAL ELECTION
LOS ANGELES COUNTY 2004

- PRES (VS) ^(VICE PRES LISTED)
- SENATE (VS)
- HOR (VS)

STATE SENATE
STATE ASSEMBLY
PERSON

CHOOSE 1 OUT OF THE 100
CANDIDATES LISTED BELOW

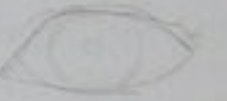
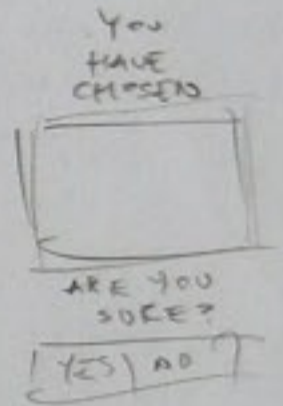

EQUIP
 5 MONTHS
 1500 +
 4
 6000
 12,000
 20,000
 22,000

15-20 TITLE
 10
 2 1/2 MINUTES

30 MINUTES

CHOOSE 3
CAND

DR. EDDIE
BOYD

HOMEOPATH
NATURPATH
EX-RN.

ART PELEER
AUGUST 9



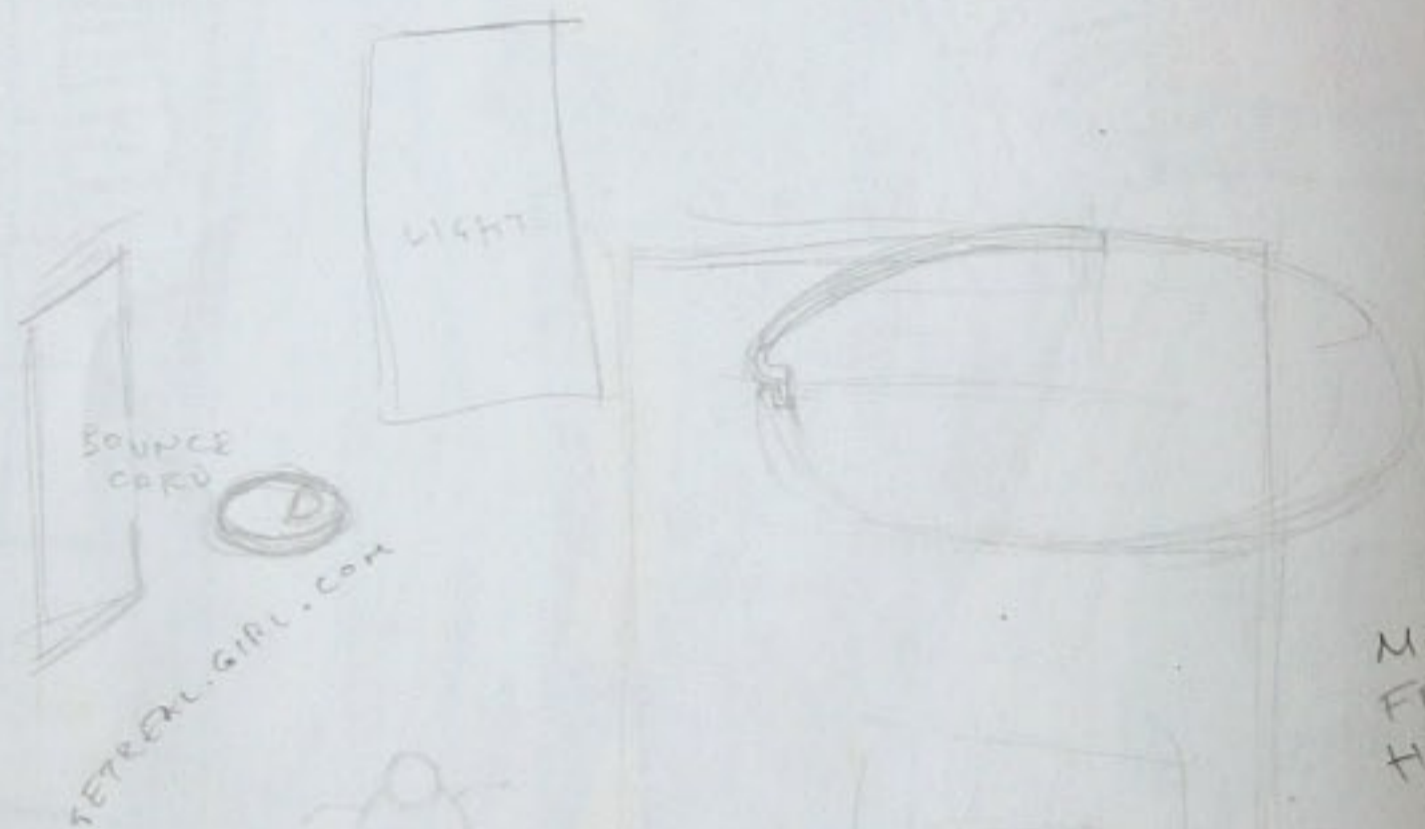
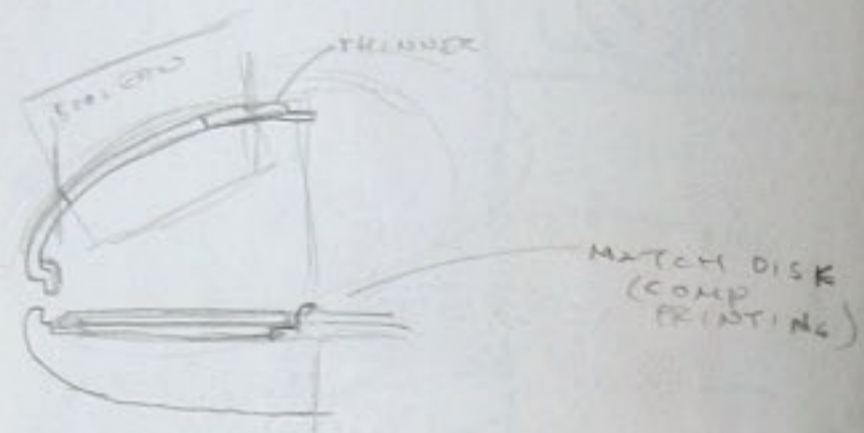

MAXIMILLIAN
FRANK
HENRY



- RUFFLES ON THE SIDE
- JT 2002 ↑

STYLISH
CARRY

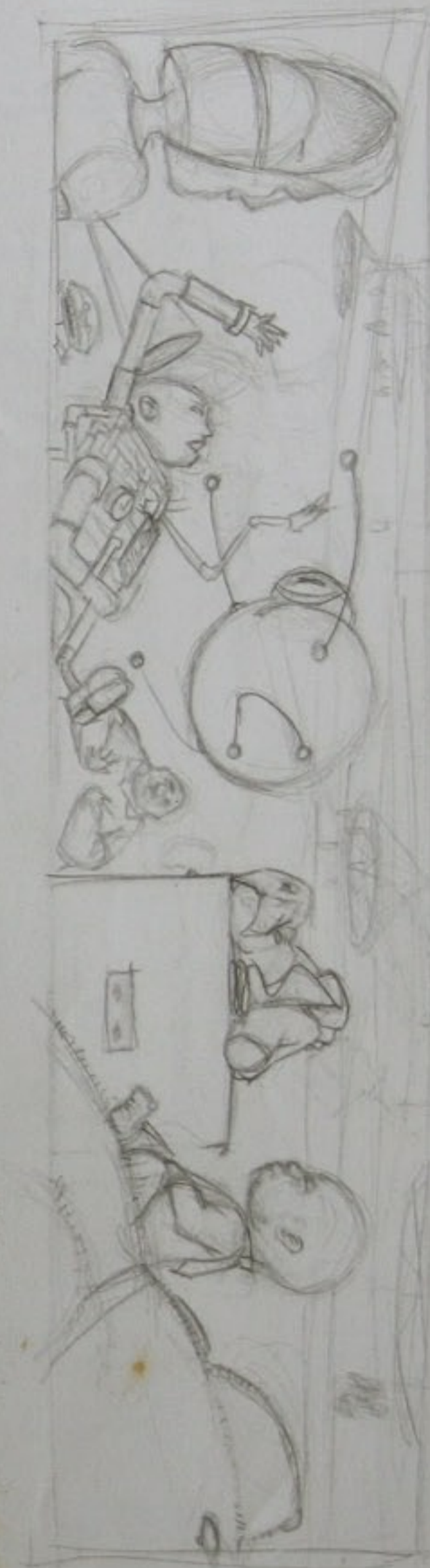

EVERYONE SEE'S THE FIRST TIME

KURT ANDREIS
 HANDRESS@ZCAGL.COM
 501 CORPORATE CENTRE #500

550-690 ANIMAL FARM REENACTMENT

FAX
 550-6939

MANGER NEWSPAPER COMPOSITE



PAINTED ANIMATED BACKGROUND (CY TWOMBLY,
 HAPPY INTO 3D SURFACES MOTHERWELL,
 OVER THE TOP HEAVY METAL FRANK KLINE,
 GRAPHICS)

COMB FACES AND 5 CO-DEPENDENT
 NATURE SITUATIONS (LEECH, (SEE) FLOWER,

NEWSBOYS

TICK LAMPHIRE EEL,
 HUMMINGBIRD, DUST WIFE
 IN BAND MEMBERS EYEBROW,
 MAGGOT IN STEAK,

PRECIOUS MOMENTS - STYLE
 NEWSBOYS BODIES W/ COMBED
 HEADS FOLLOWING SHEPHERD

CHRISTMAS THEMED
 ANIMATION
 SHEPHERDS JOURNATION
 TO MANGER FIGHTING
 LIKE BROTHERS (MAYN
 + JOSEPH ROLL RIES)
 (+ JESUS)
 ?

CRUDE DRAWINGS UNIED
 TOGETHER IN 3D SPACE
 WITH LINE DRAWING &
 "PRINT" FILTERS APPLIED
 TO HEADS & BODIES

\$1500
 \$700
 \$1000
 \$400
 4500

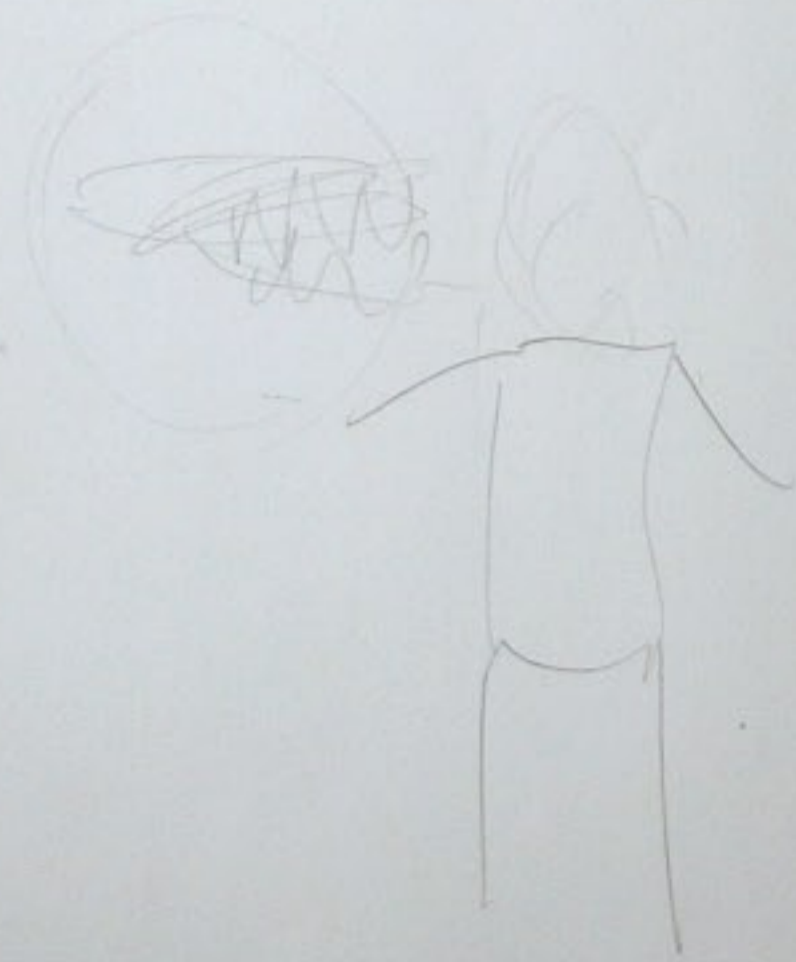

AFERLUKE
 SETTING

MILLSTONE
 MA. 0152



Sketch of
the building

Sketch of
the people



FRAN TALBOT
LITTLE PLANET

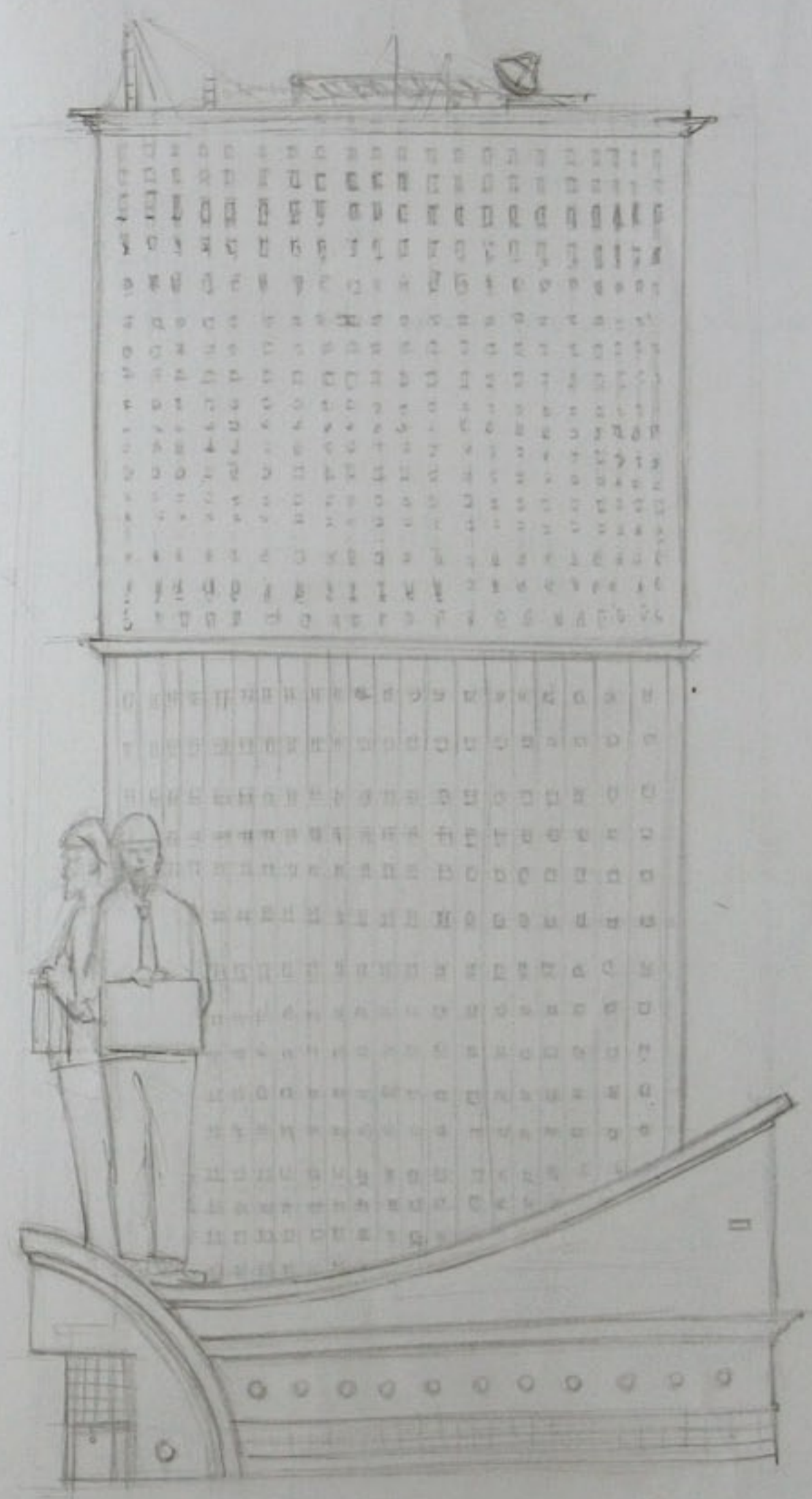

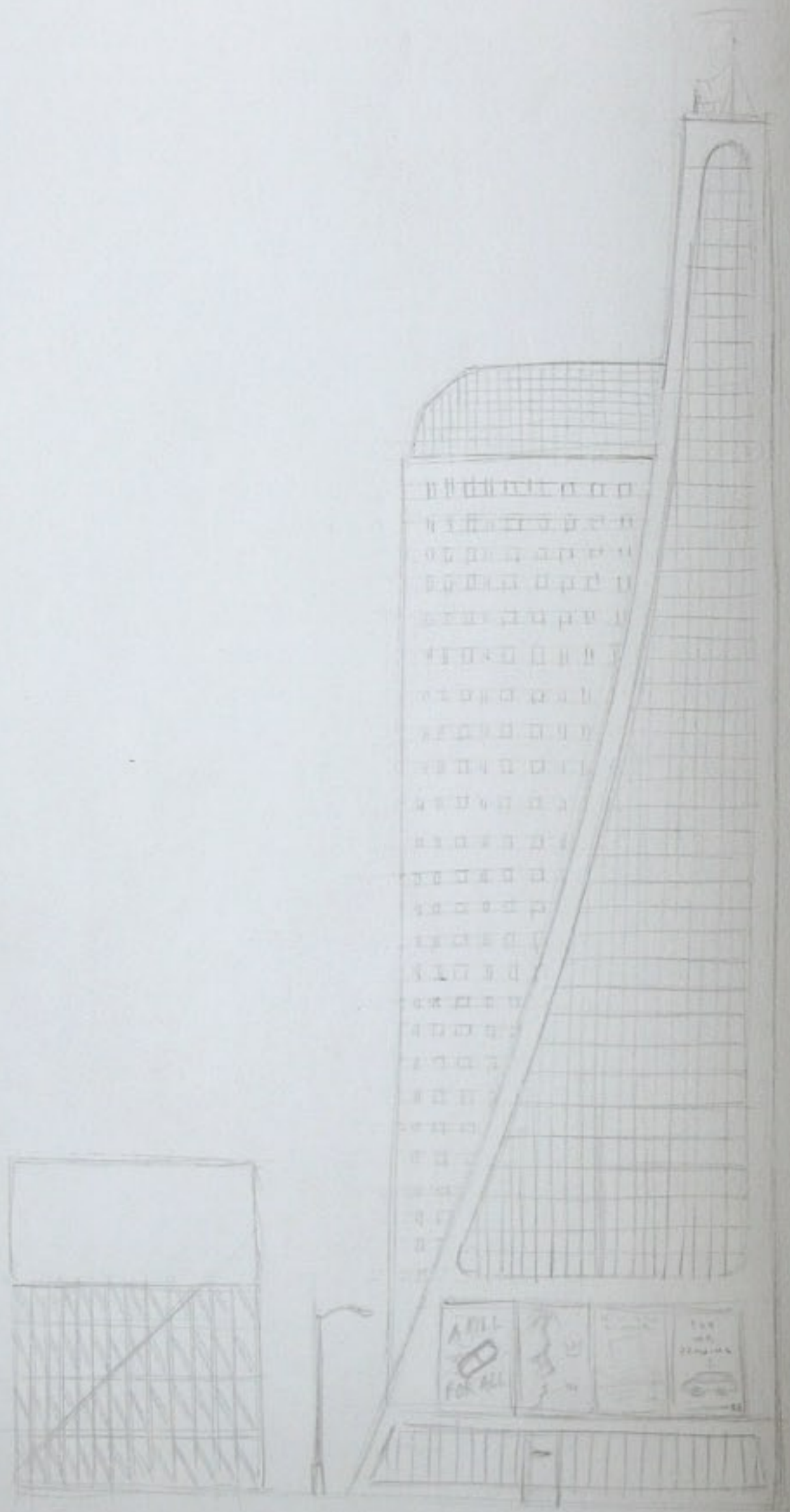

Le CUP FRENCH DRAIN

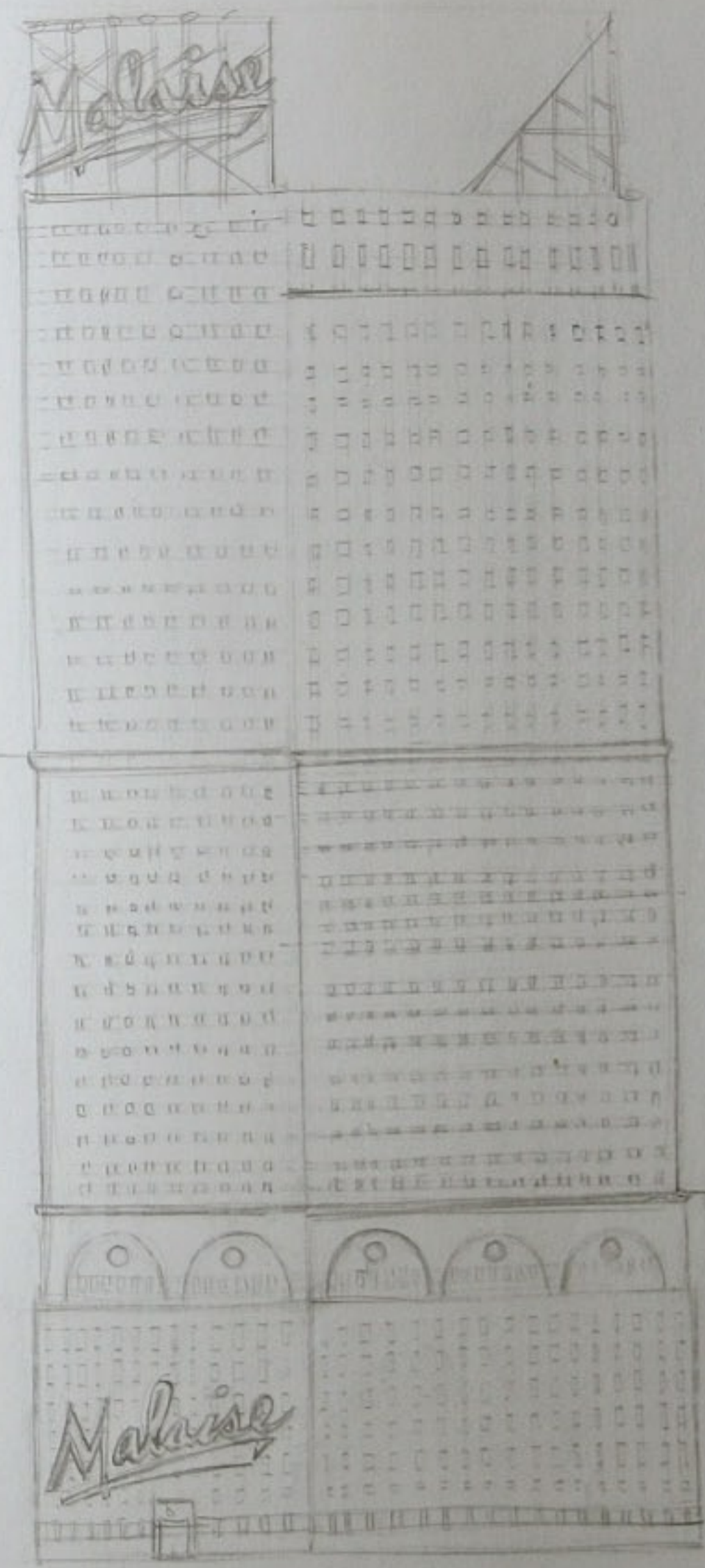

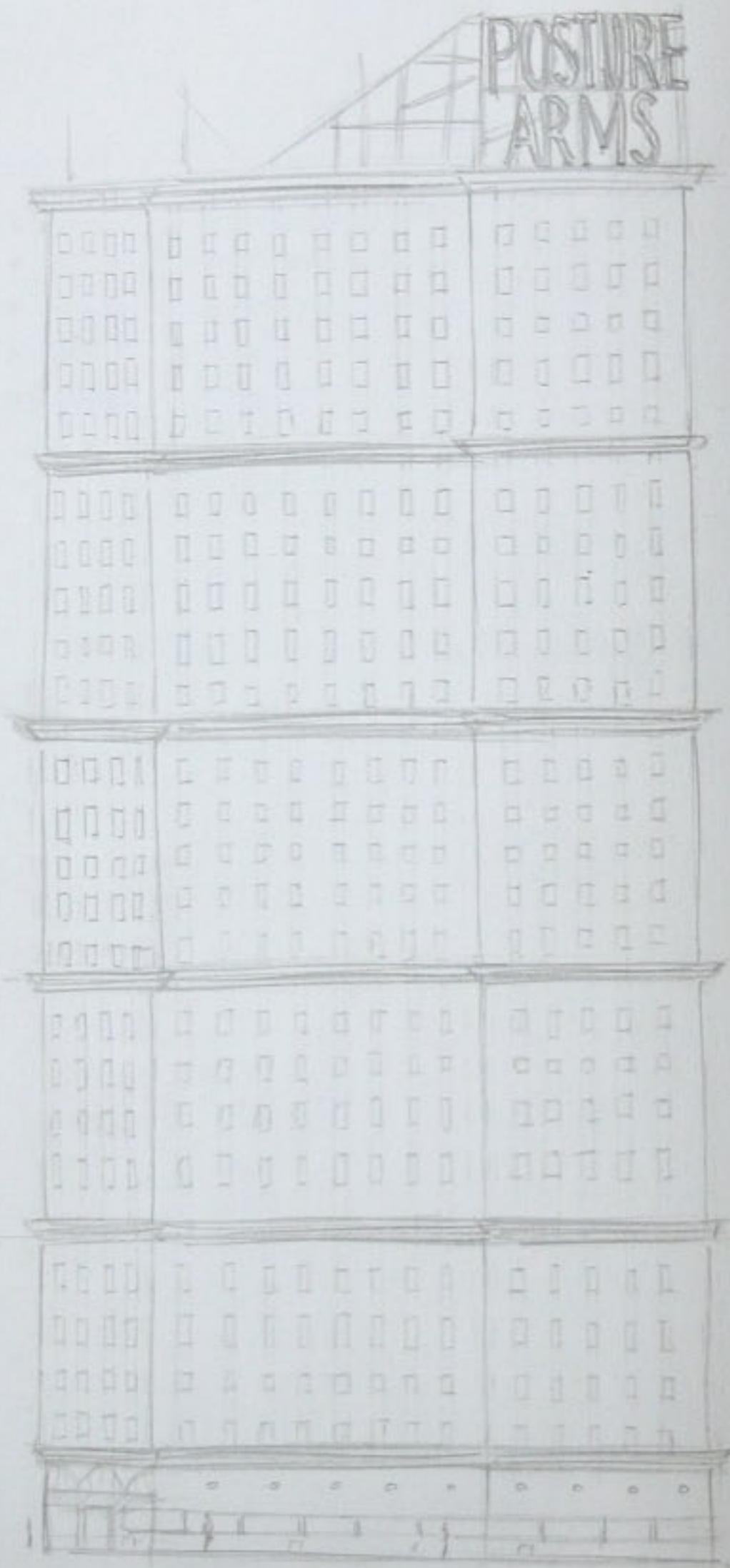

Front view

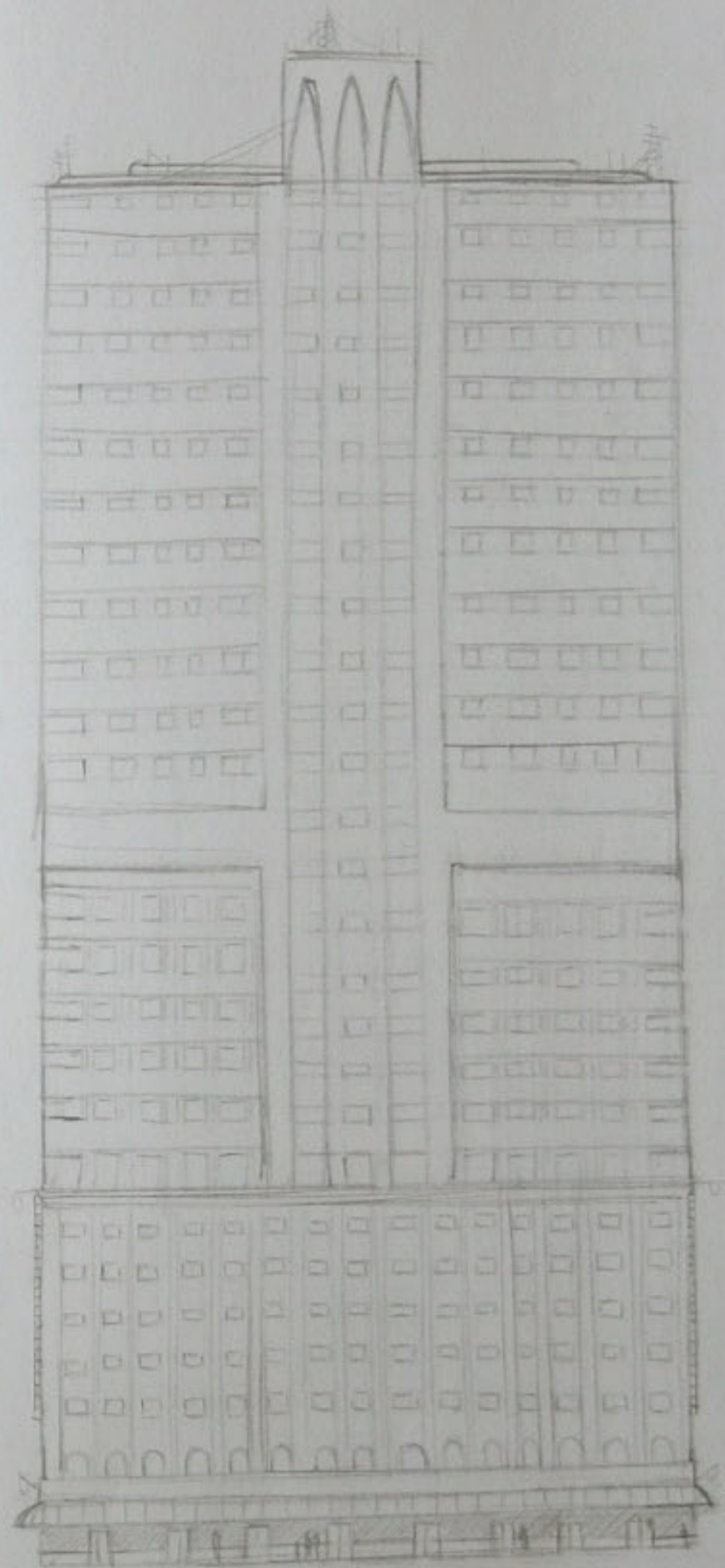

375 St. B 172 5222
109 194
130 70
144 512

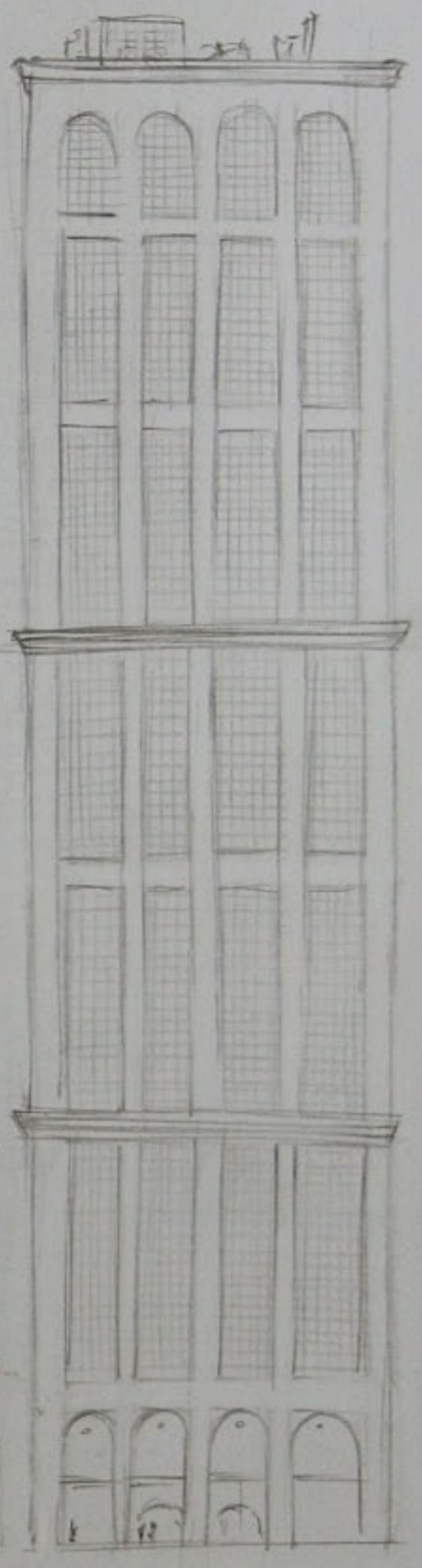
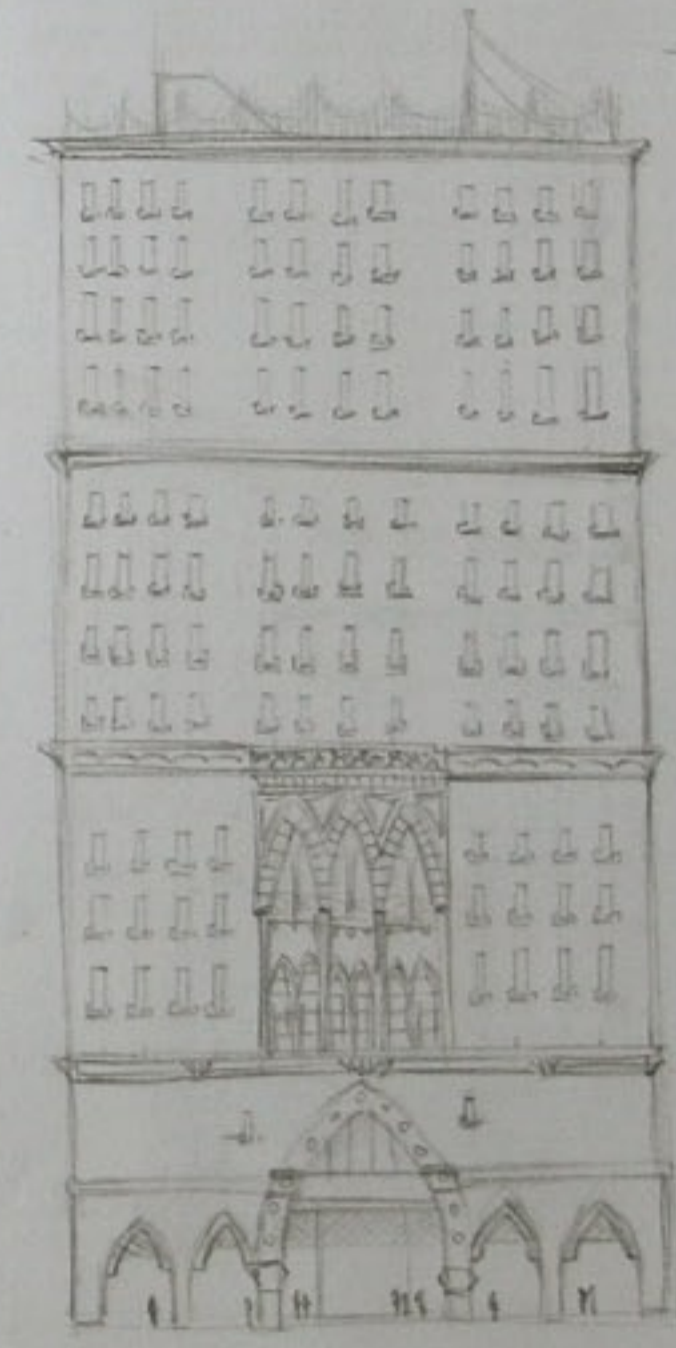
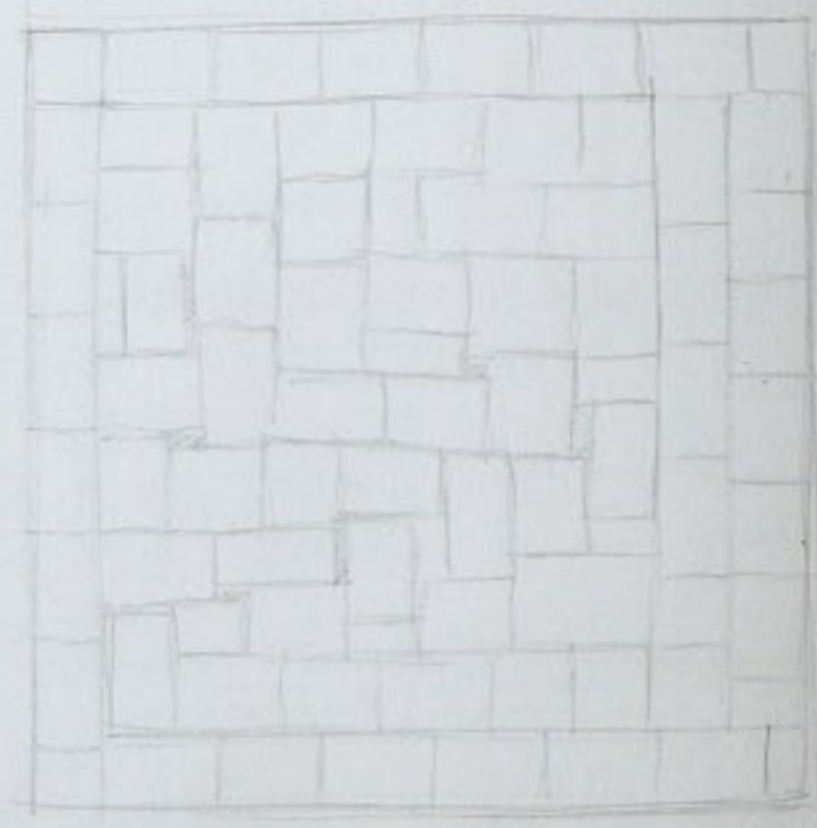
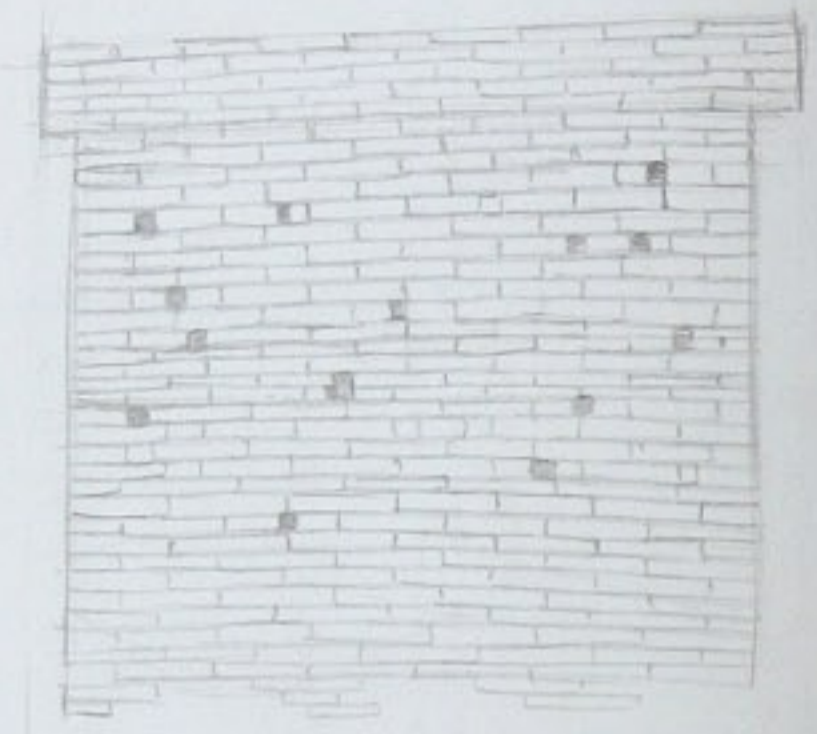

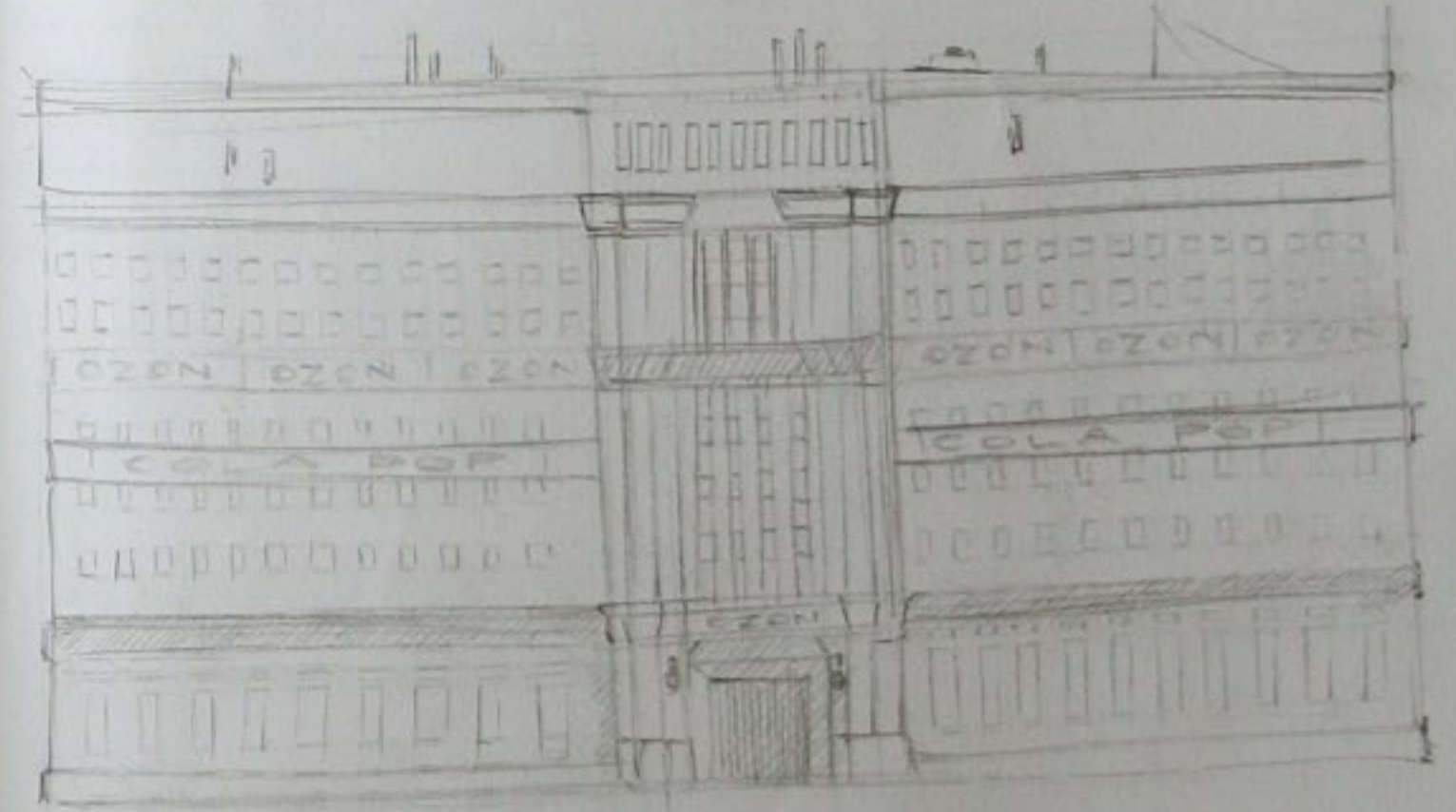
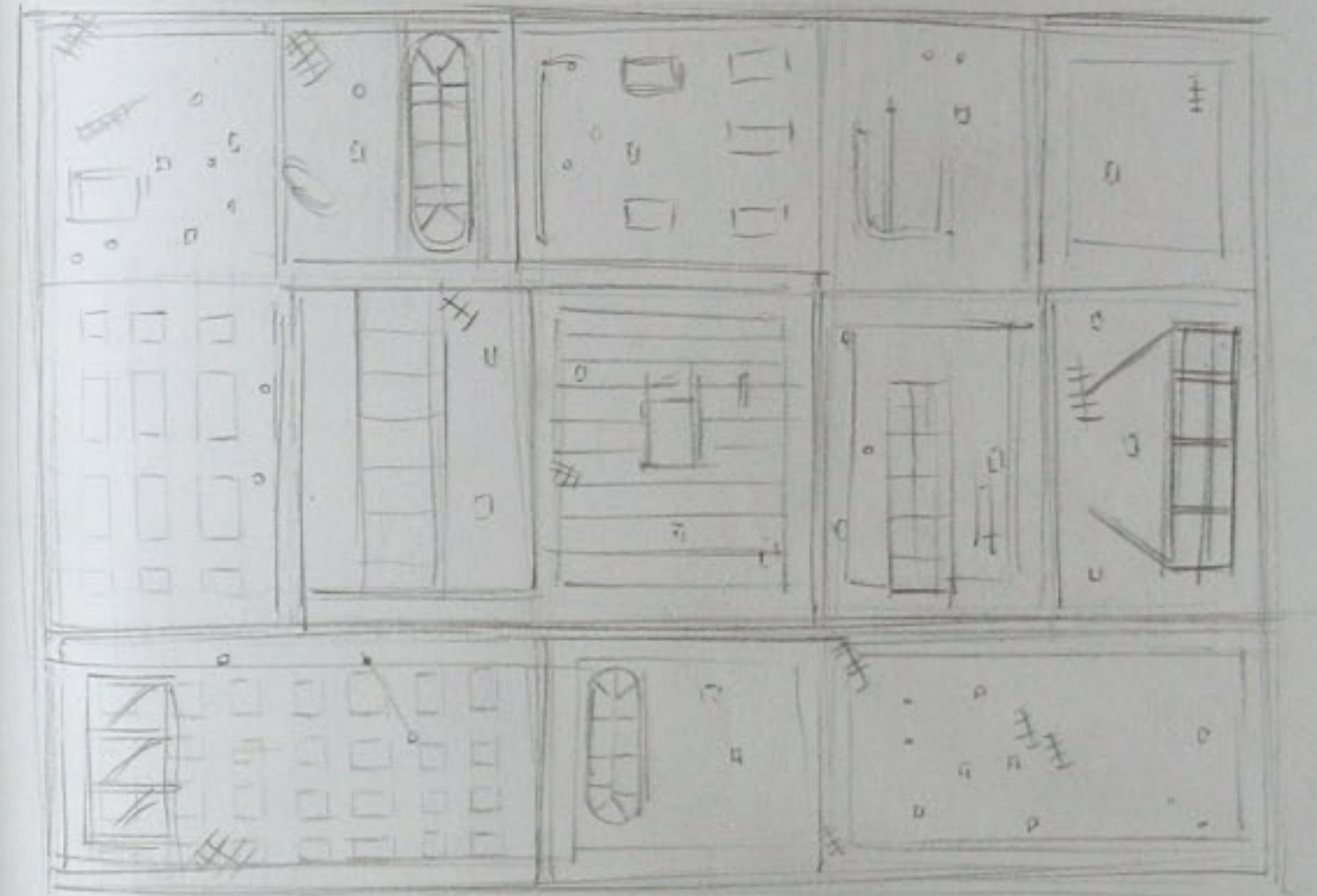
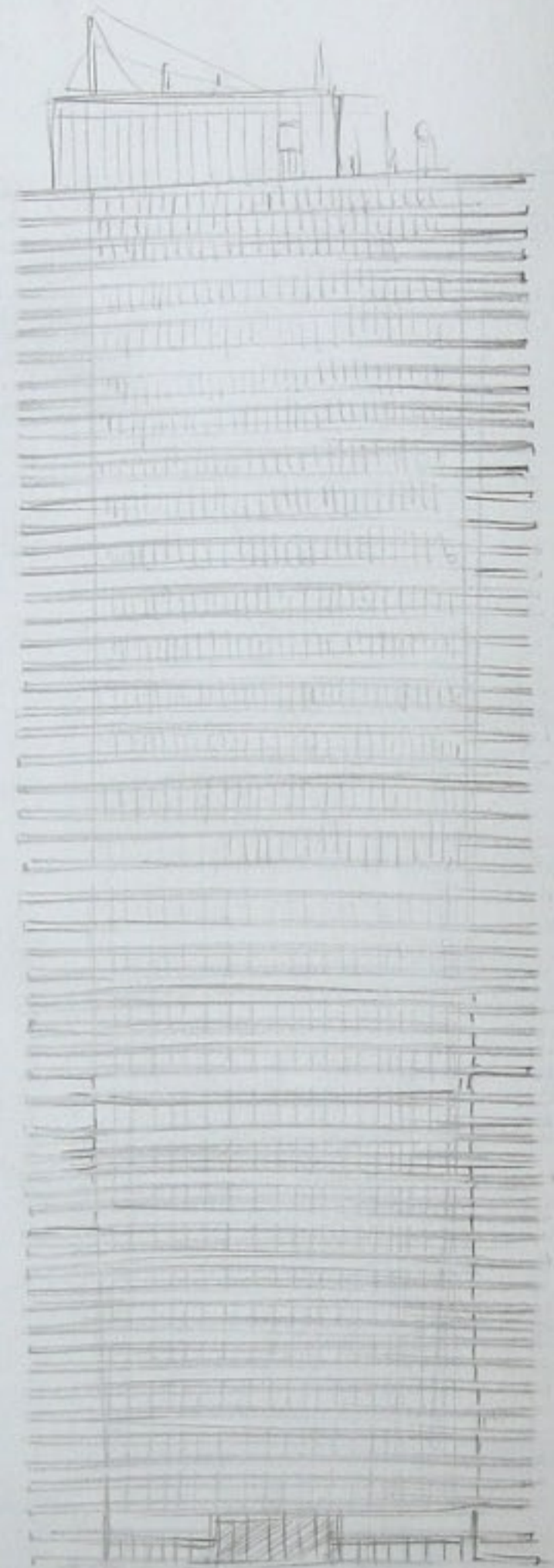

FIGHTING FAMILY
DEATH OF IDEALS
DISILLUSION OF



I SHOULD WRITE
SOME BOOKS!



TALK TO HAWES ABOUT CHANGING SLEEPING PLACE
24 OCT - PUMPKIN COOKIES - R WAIVER



Don't know
327 6472

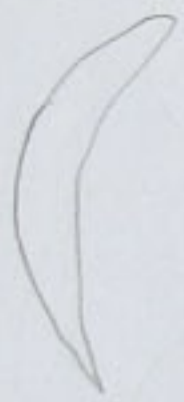

2004/2003

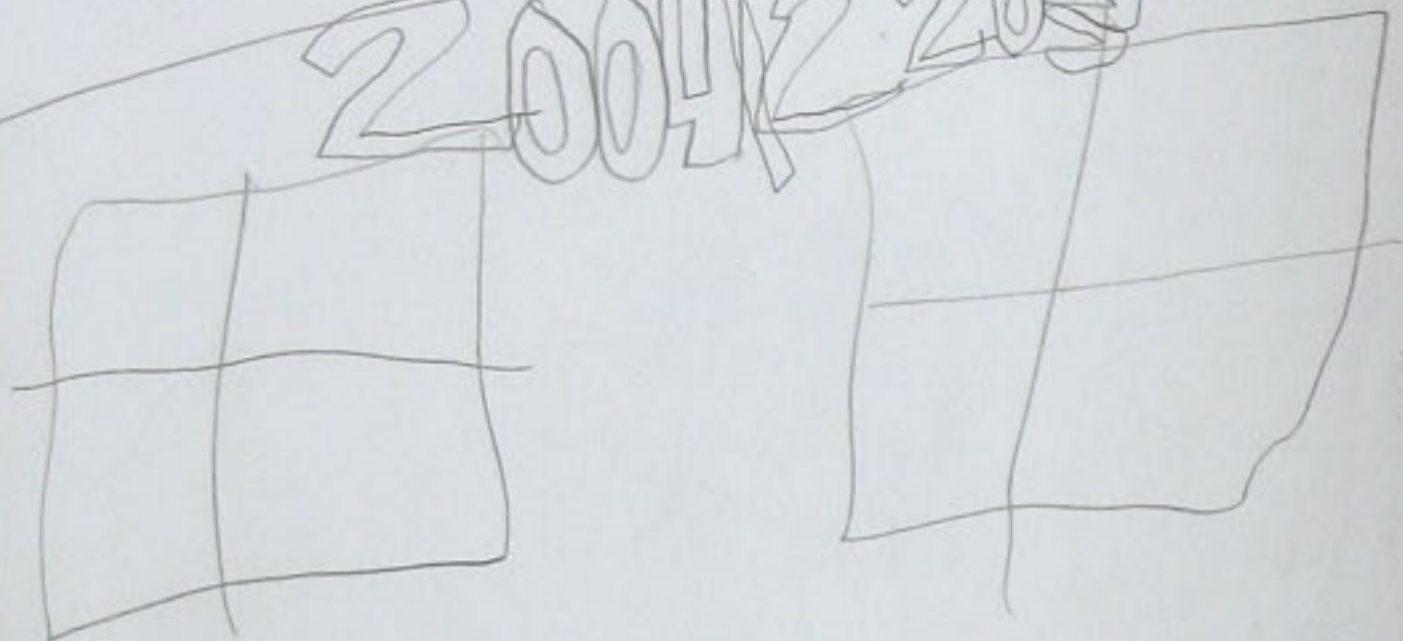

ELLA FITZGERALD
BALIN ST. BLUES
COLUMBIAN ORCHESTRA



CHURCHMAN WAS DICKED
FOR THE MATURITY OF
HIS OFFICE TERM

H I R E S

A STOPPED @ 00:28:20

B2 STOPPED @ 01:56:20

C STOPPED @ 02:56:28



THE TIME IS ALMOST UP!

SCAN TRON Detach All Espinal

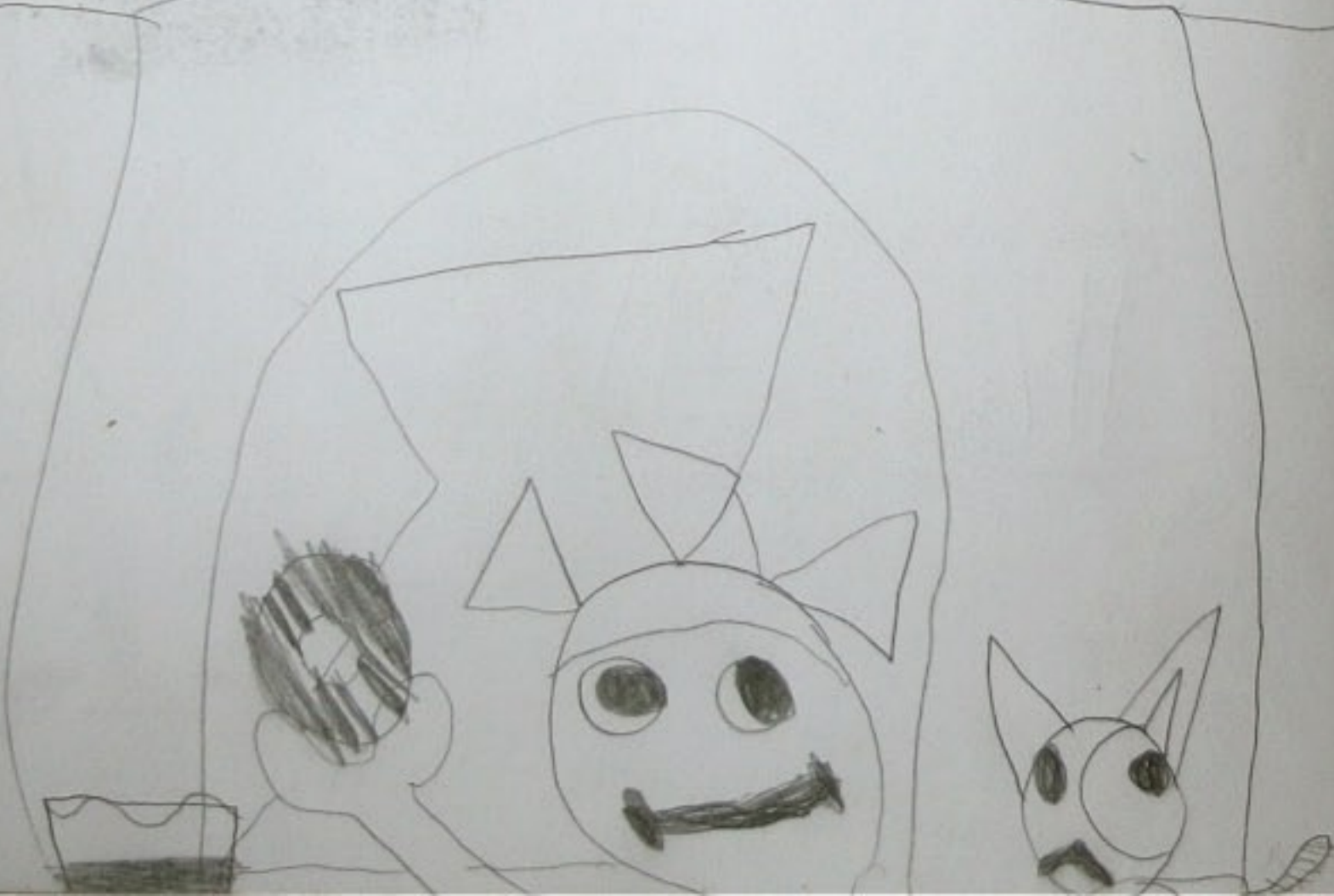
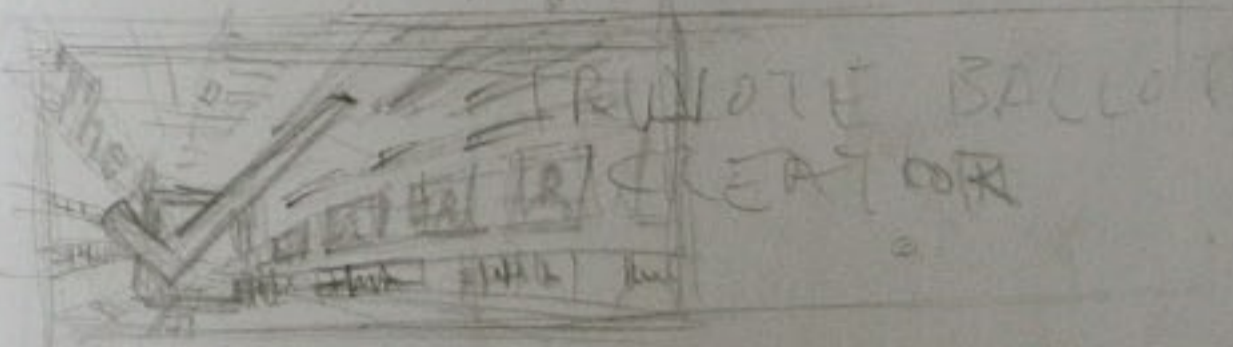

530 TRX TUX ON
600
730



PFC
COPP
CODE:
67A3

1546554
9A4436

MILLIE
MILLS
MONITOR
SUMMARY
MIXING WITH
COMB

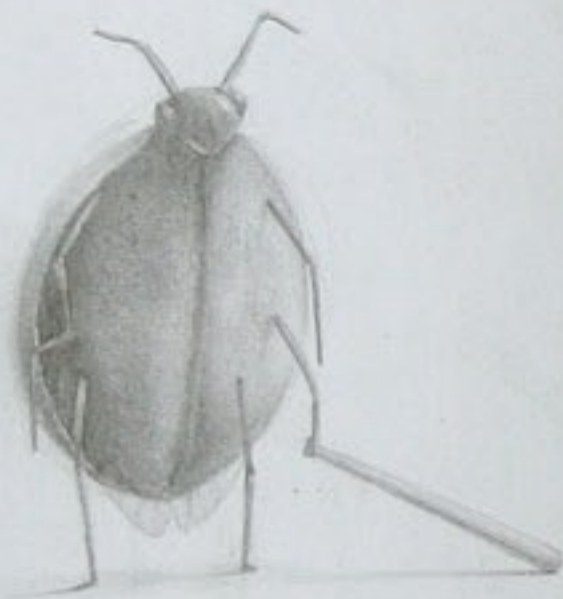

WHO ELSE IS SATISFIED WITH
"JUST APHIDS?"

LOHO
709807125
BRANDON
MONDAY
627255323
52353229

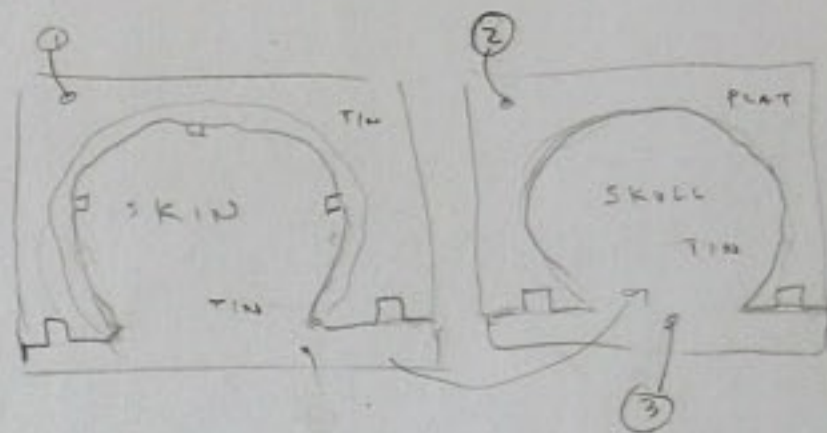

LOOKUP: ARMATURE
SPINT
TYPES (MACHINING)

- ① SKULL
- ② CAST SKIN
- ③ BUILDUP HEAD
- ④ CAST HEAD

ETOCASIES ARE
ALWAYS WHITE
GLASS

GLASS PLATE?

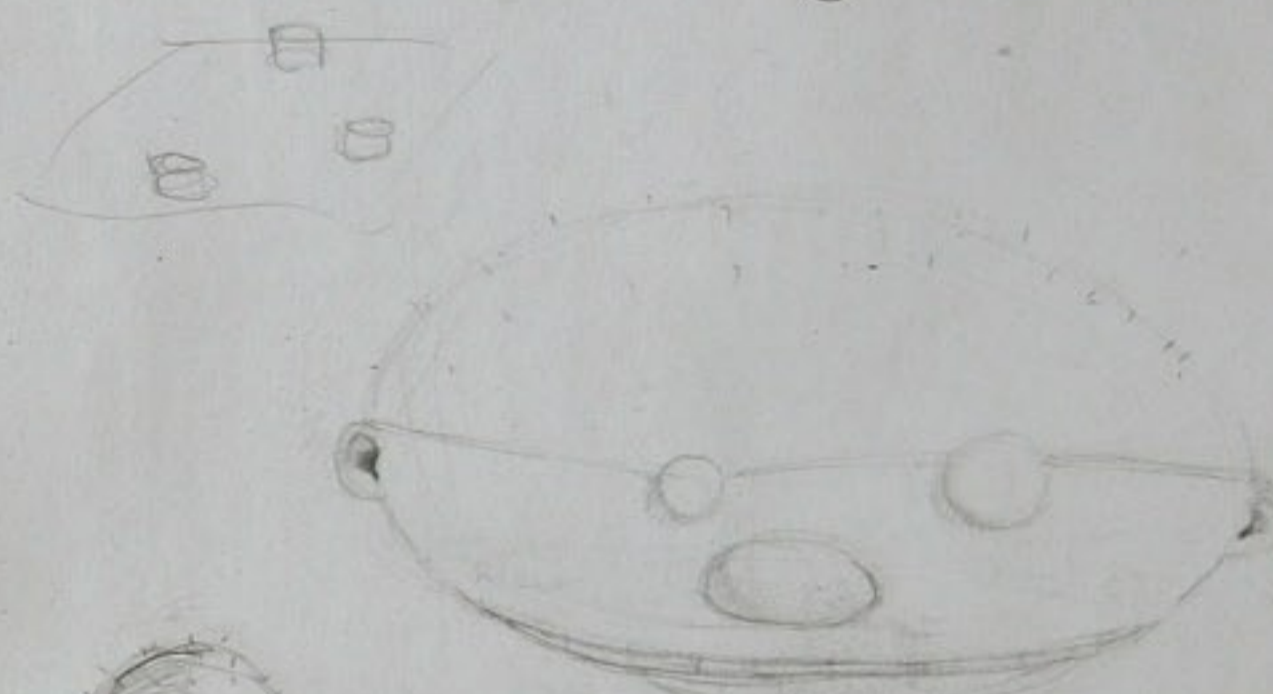

SKULL & JAWBONE - TBL
HEAD SKIN - KIN SKIN
GLASSES - REPLACE TB

ARMS & LEGS -
SKIN FLEX BRUSH

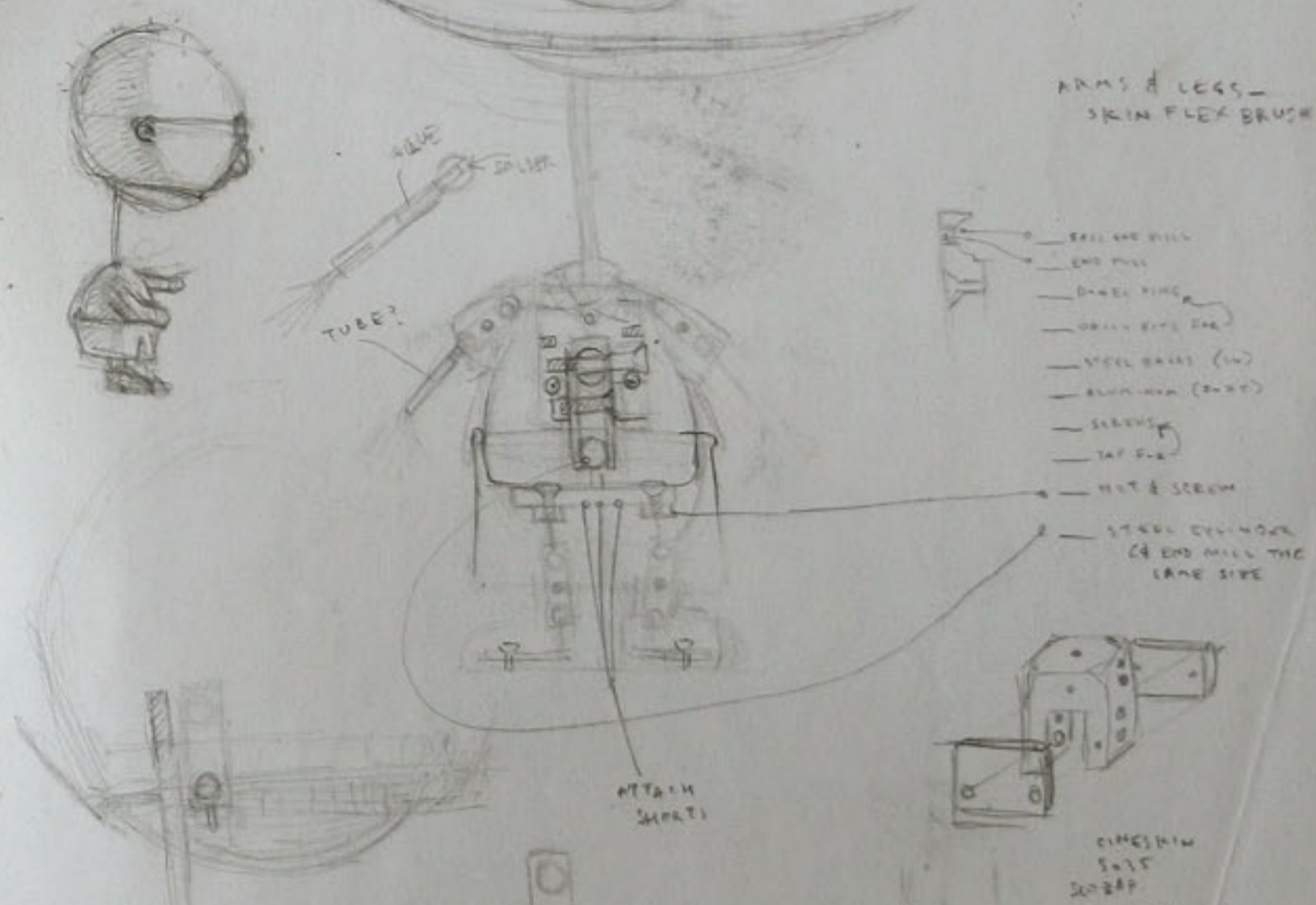

- BALL END PULL
- END PULL
- DAMEL PINE
- DRILL END END
- STEEL BRASS (IN)
- ALUMINUM (B-W)
- SCREWS
- TAP P-B
- NUT & SCREW
- STEEL DIVIDER (4 END MILL THE SAME SIDE)

CINEMIN
S-15
SCULPT BIC

2/56
#51

2500/WK
 2500/WK
 1500/WK
 1500/WK

52
 20
 116,000 - CG OPERATORS
 35,000 - SOFTWARE
 ? - HARDWARE
 360,000 - PURCHASE
 ? - MUSIC & SOUNDTRACK
 12,000 - STUDIO EXPENSES

PARKED
 305 3055
 W 742 1111

640 SQFT

- I. PREPRODUCTION
 A. STORY
 B. BOARDING
 C. PRODUCTION DESIGN
 D. SCRIPT
- II. PREVISUALIZATION
 A. ROUGH VOICE & SOUNDTRACK
 B. ANIMATIC
 C.
- III. PRODUCTION
 A. FINAL AUDIO
 B.

BISQUIT POWDER - 99.00 HRS (2000)
 BISQUIT - 600
 3/4 BCP WOOD - 18.00 EA x 20 = 360 \$
 SANDER - 34.00/DAY TAG PAPER
 POLYURETHANE - 24 HOURS - 120 GAL (600 SQFT)
 STAIN - 8 HRS MIN - 17 GAL (600 SQFT)
 SANDING PADS - 5 \$/EA
 MIN SPIRITS - 40

8550



- 40 (E) → (5) (N) → (2) (H) B →
 (E) GALLATIOW RD
 (W) STREETS FORMAL SHOP
 868-9589.
 (E) GALLATIOW
 (O) H.B. → 3 MILES
 (R) GRACE BAPTIST CH.
 (S) O.H.B.

ST. BERNARD
 KNIGHT

MATT HUESMANN
 (615) 791-0195

(850) 231-0658 FL #
 (615) 473-7364
 LITTLE DOL
 SCRUFFY

ED SPRUNGER
 - OPEN EYES / CLOSED EYES
 - VIOLINS YELLING VS. WHISTLING
 AWAKE VS. SLEEPING
 - LAP CLAP CLAP - WHEN EYES
 ARE CLOSED / OPEN

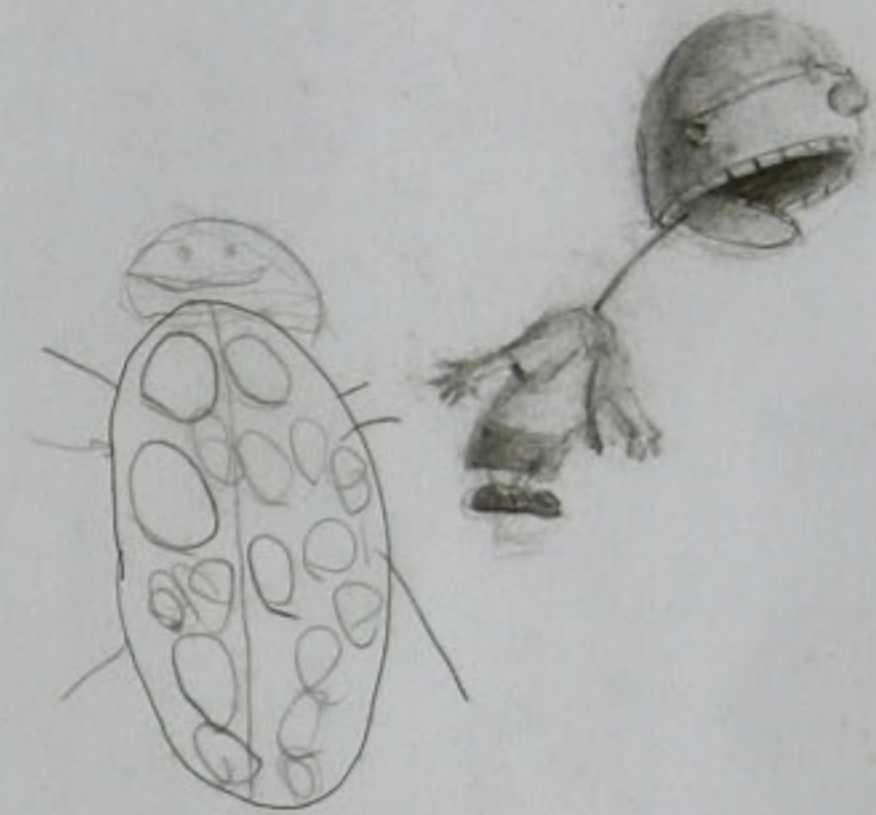

14 36
 100 36
 - 32 36

 68 00
 100 36

 168 36

157 x 36

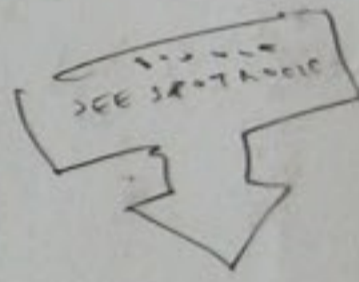

13 x 3

39 SQFT

Dr. Tina T. Smith
 tsmith31@TNSSTATE.EDU
 tnamtsmith@aol.com

-WAIT TO TELL WHAT
 TO SAY AFTER STUMPER
 -INCLUDE SELF IN PLAY



DR. E. ILLUS.
 ELLIE
 15-- 876 6425
 X235

1900 842 2122

IDEA: Back pack that snaps off
 to store flat when not
 in use - + also cool shape
 diff. from usual.



IT'S TOO
TIGHT.



ONE

CARL HEINRICH BLOCK

KIRK RICHARDS

ARTIST IN TOWN
GREEN HILLS

STARTING POINT SPACE MOVEMENT (2001 QUARTERLINE)
ETCHING CARDS

SEAL-7A



OUT
Y

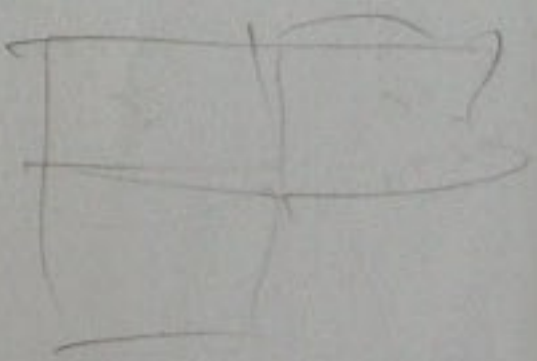

AND PUDDING.



DRAW EVENTS
FOR SEQUENCING



WELL
FROM SICKY TO
SIST PLAIN
AWFUL



LEGS ON BOTH
SIDES

CASTERS
UNDERNEATH

DIGITAL VOTING SOLUTION LOG



AL 36301

1. 2000 12
MATT 4/10/02

SPICED UP 7-3-20

-PJK READY PICTURE
-PRINTED PICTURE
-PAWPRINT

SOUND FX LIST
ELECTROGUTE



BMCCLELLAN@TNSTATE.EDU

1. 2000 12
5
1. 2000
2. 2000
3. 2000
4. 2000

(15) 383-1010
#172 903 20

HYGIENE - PICKING
STUFF
FROM TEETH

SECRET NIGHT
NUMBERS



MICHAEL MADRID
423-9655
DESIGNER STUDENT
(CALIFORNIA)



HANDICAP ACCESS

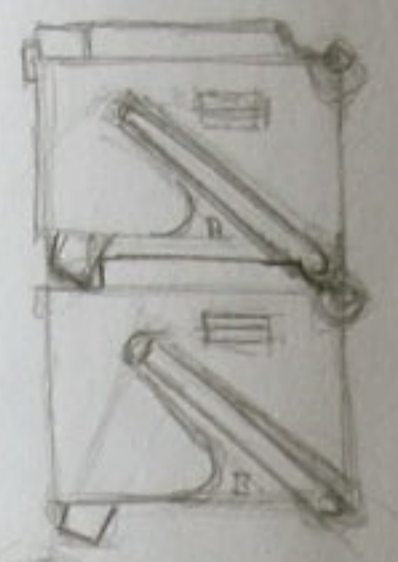

TEL 408 235 8320

GEORGE WIRTANEN
800 352 5844 X 1159

3 TO 4 FEET
TO BUILD PERIOD

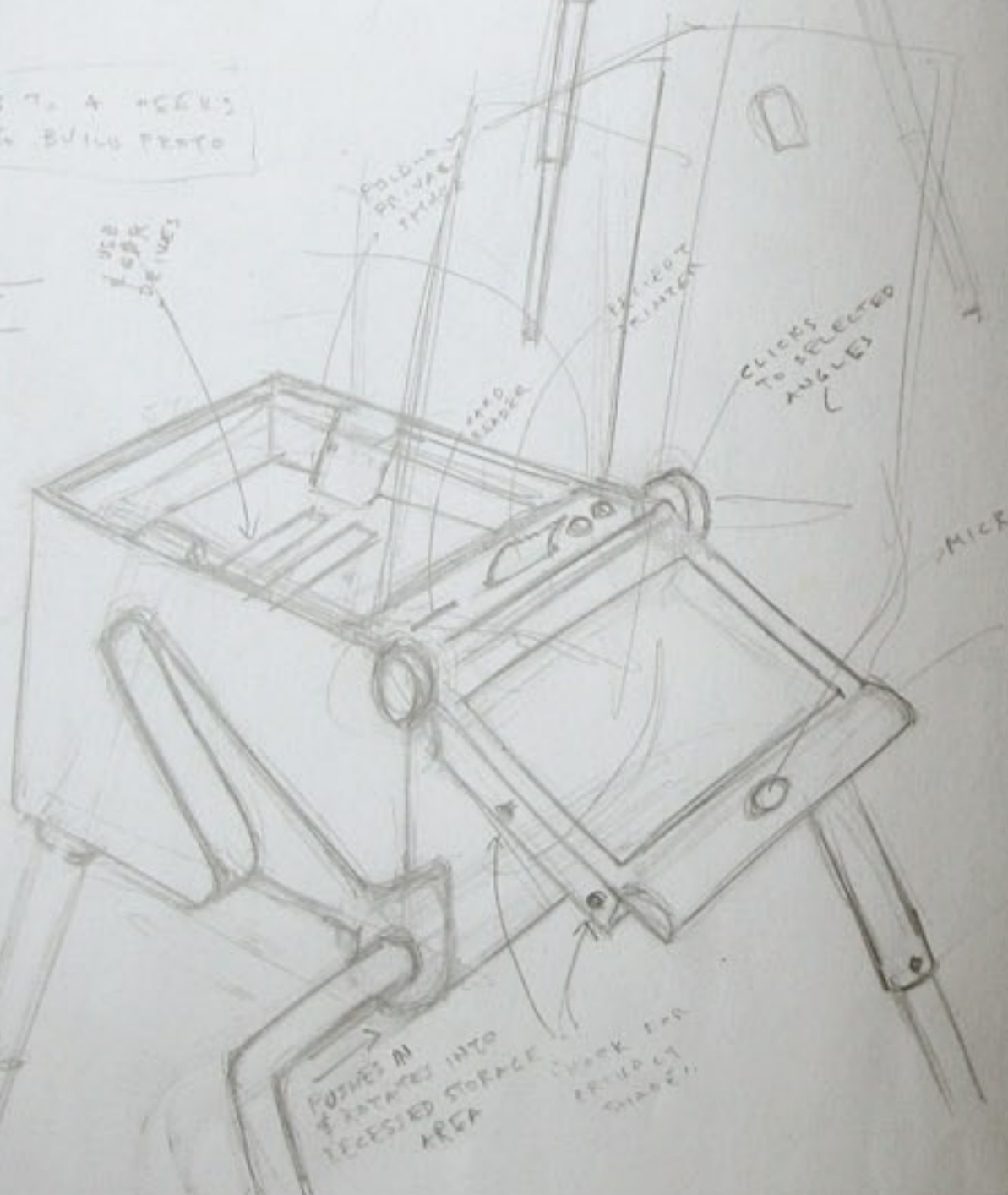

FOLDING
DRIVE
THROUGH

ADJUST
MINOR

CLICKS
TO SELECTED
ANGLES

MICROPHONE

WRIST
REST
NOT PADDED,
THOUGH

PUSHES IN
FRONT INTO
RECESSED STORAGE
AREA

HOOK FOR
FRONT OF
TABLE

INDENTATION
FOR STORING

COMING
FROM
USING
FISHING
TRUCKS
CONSTRUCTION EQUIPMENT
SCHECT
LITARY

TOUR @ LAS
VEGAS FOR
MEETING
SUBJECT
FINANCIAL
STATEMENT

8-2 TRAVEL
2-4 HRS
4-3 OTHER
2-1 HOUSE

JOHN
800 275 2273
889 X41156

#17290370

HOLLYWOOD REPORTER

NEW YORK

NYPG.COM

CHICAGO FILM COMMISSION



USER
INSTRUCTIONS

BLUBBING



HOLES TO HOOK INTO
SIDE OF TOUCHSCREEN

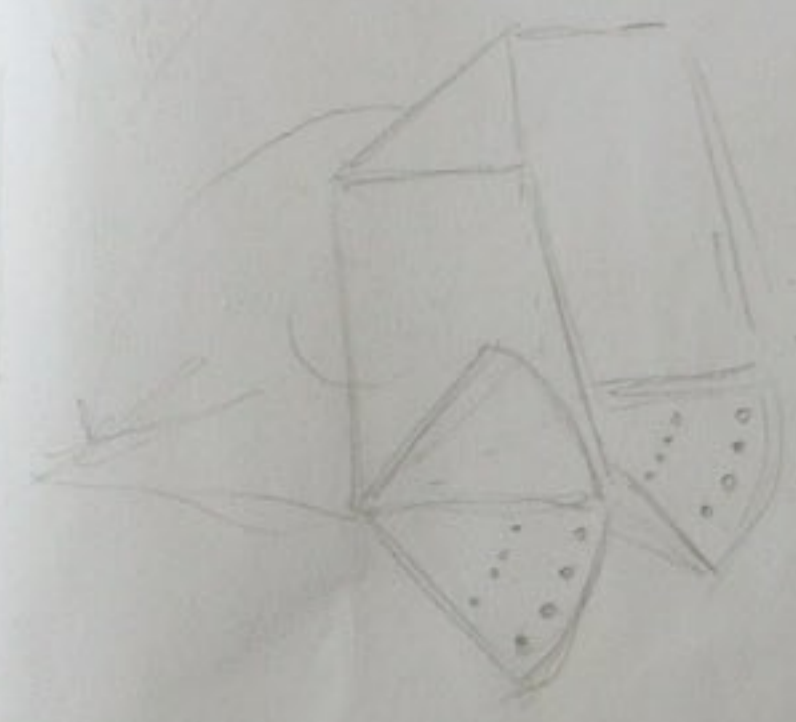
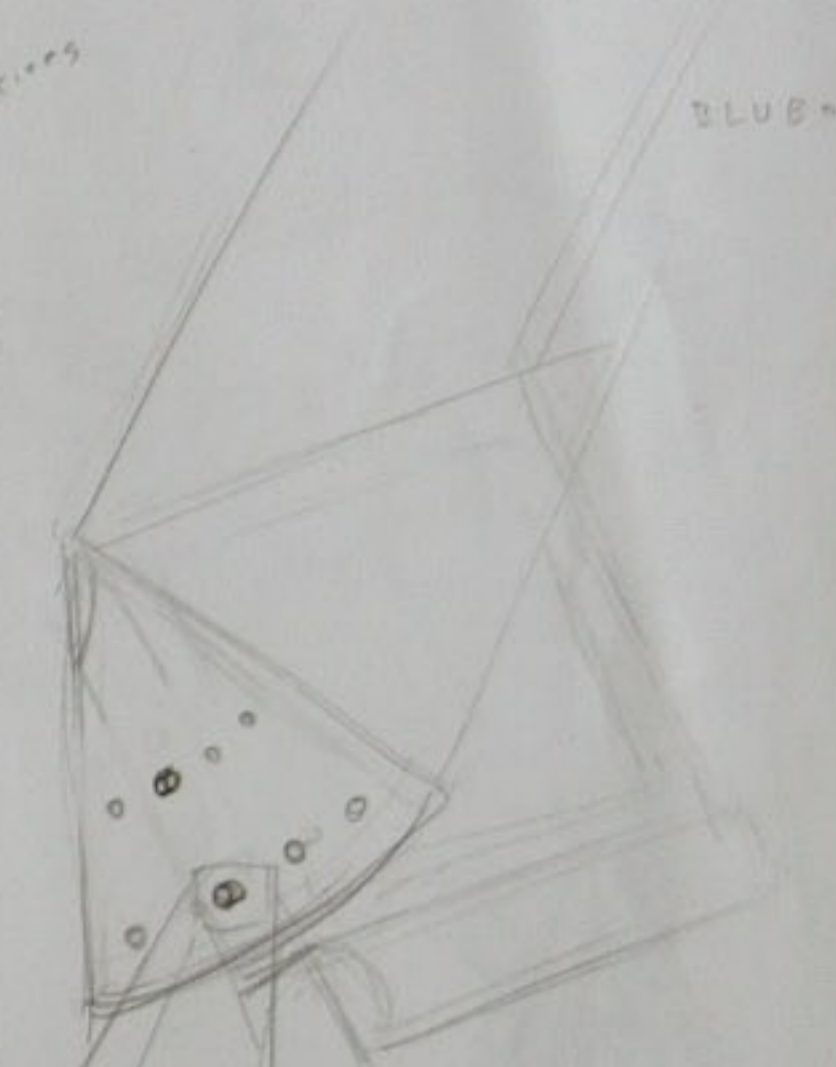

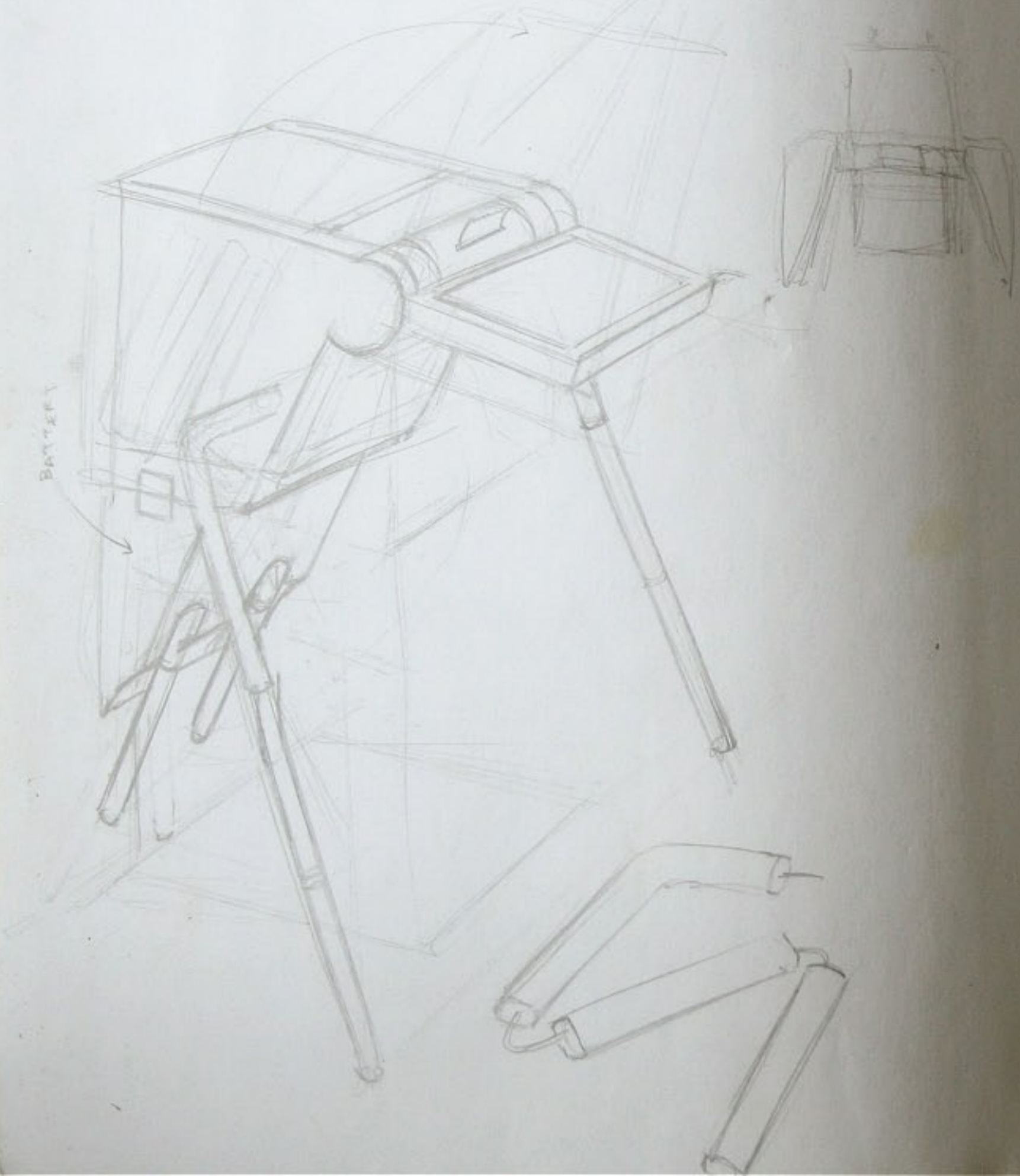
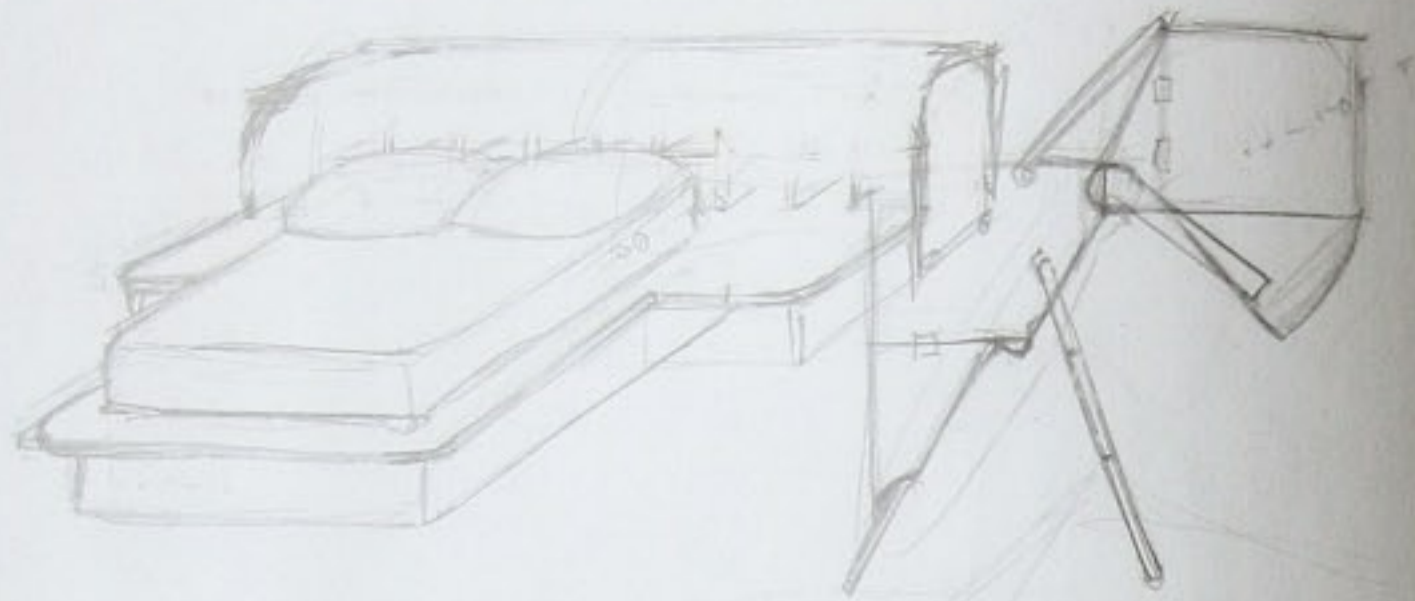

JOY MILLER - PE TEACHER DOES TUTOR GROUPS
FORTUNE COOKIES FOR REWARD VS. SKITTLES, M&Ms, FRING POPS
ROBERT SANDER BOOK
MAY ANN FIFE - 662-3015 - CALL TO VISIT CLASS ROOM
VICKI GRANTHAM - FIRST GRADE 646-0492

TUTORING NATHANIEL (MEET @ PARK FOR PLAY DATE)

VERTICAL - ALL THESE ARE IN THE REAR OF THE ROOM - SEE HOW THEY CAN BE
SPRAY AND SERIALIZE AS WELL AS THE OTHERS

RCR = SAZ@YAHOO.COM

FARM BUREAU
595-5552

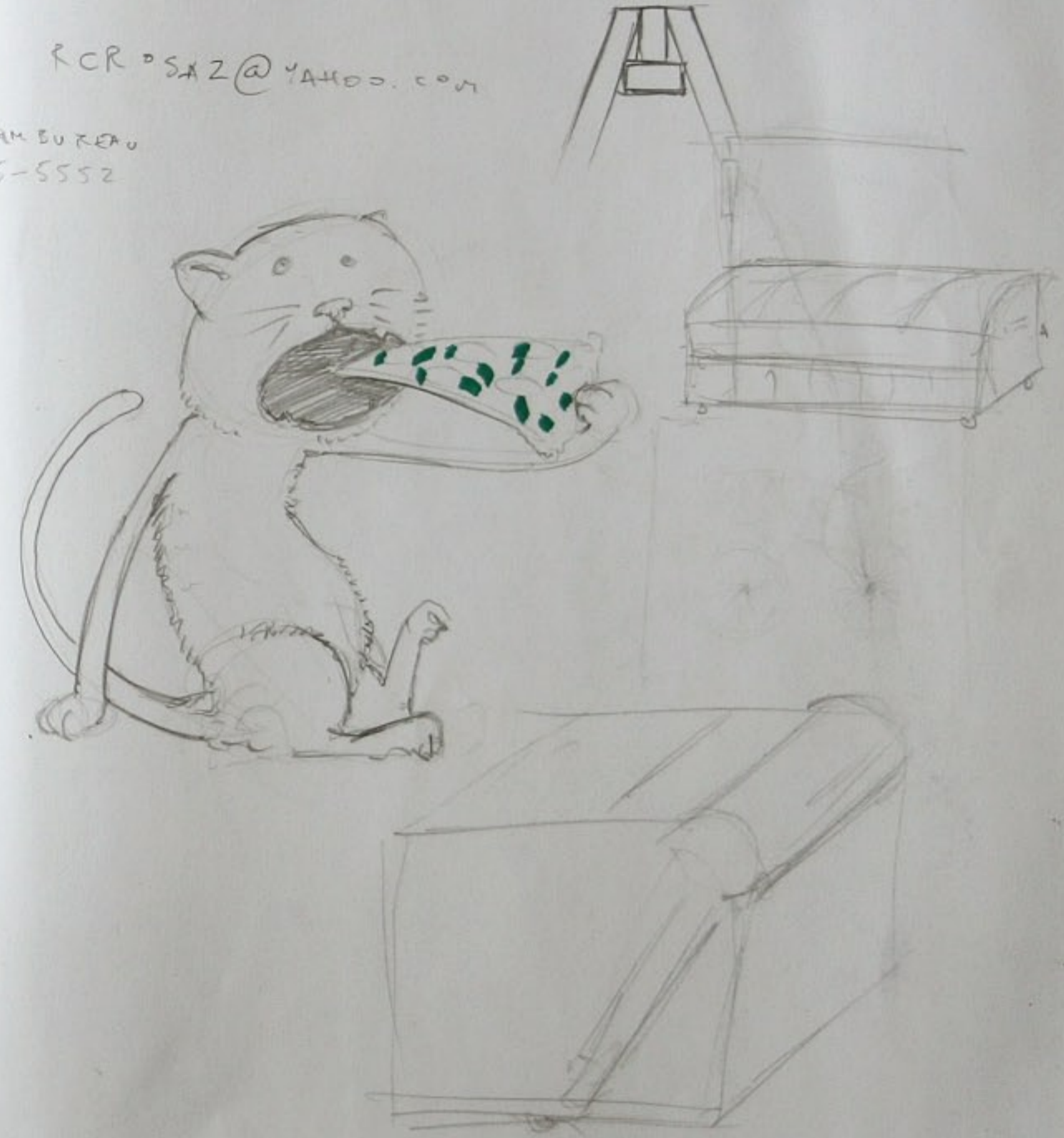

SCENE GENIE
REALVIZ.

ALPHAVIZ
25.01.02



ATLANTA CAD SERVICES
PETER 270 363 8704

COMMISSION FOR
3D

CLOTH SIMULATOR
ST FLEX. 012



12 14 16 18 20 22 24

"KATIE" (W. W.)
MILWAUKEE 10. 1997

ATOMIC PICTURES IN ALA

SHIELA
MAY 1970
9.3.74

HAPPY

CHILDREN'S IDEAS
GIRL
PLAY & HOTEL
"KAY"

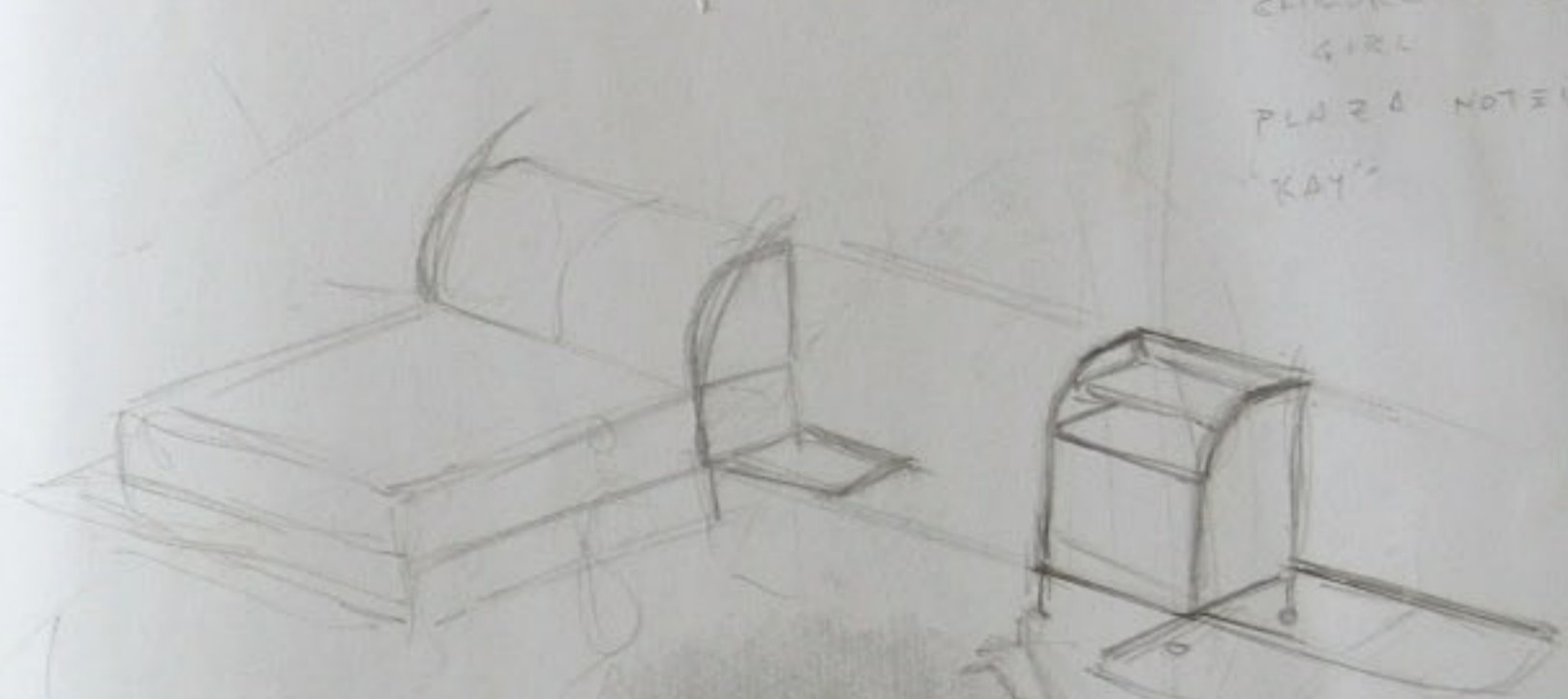

| GO TO | STAYAWAY |
|-----------|---------------|
| HAPPY | LIFELESS |
| AS CHILD | FUNNY |
| ENERGETIC | CHARICATURE |
| | CLUNKY STOP- |
| | MOTION SETUPS |

- spilled milk at lunch time
- Fell from bike. (sad).
- waiting turn to swing. (bored)



RECORD PLAYER W/SONG
 (CALMATION BY FIRE)
 REACHING OUT TO HOLD HER

STREET CAFE PAINTING ON
 TABLE - BIKE PARKED BEHIND
 HER - TAXI FLASHED LIGHTS



-TWEEED!

JUMP TO INSIDE
 WOODS THEN
 BACK TO EAR
 ROOM VIEW

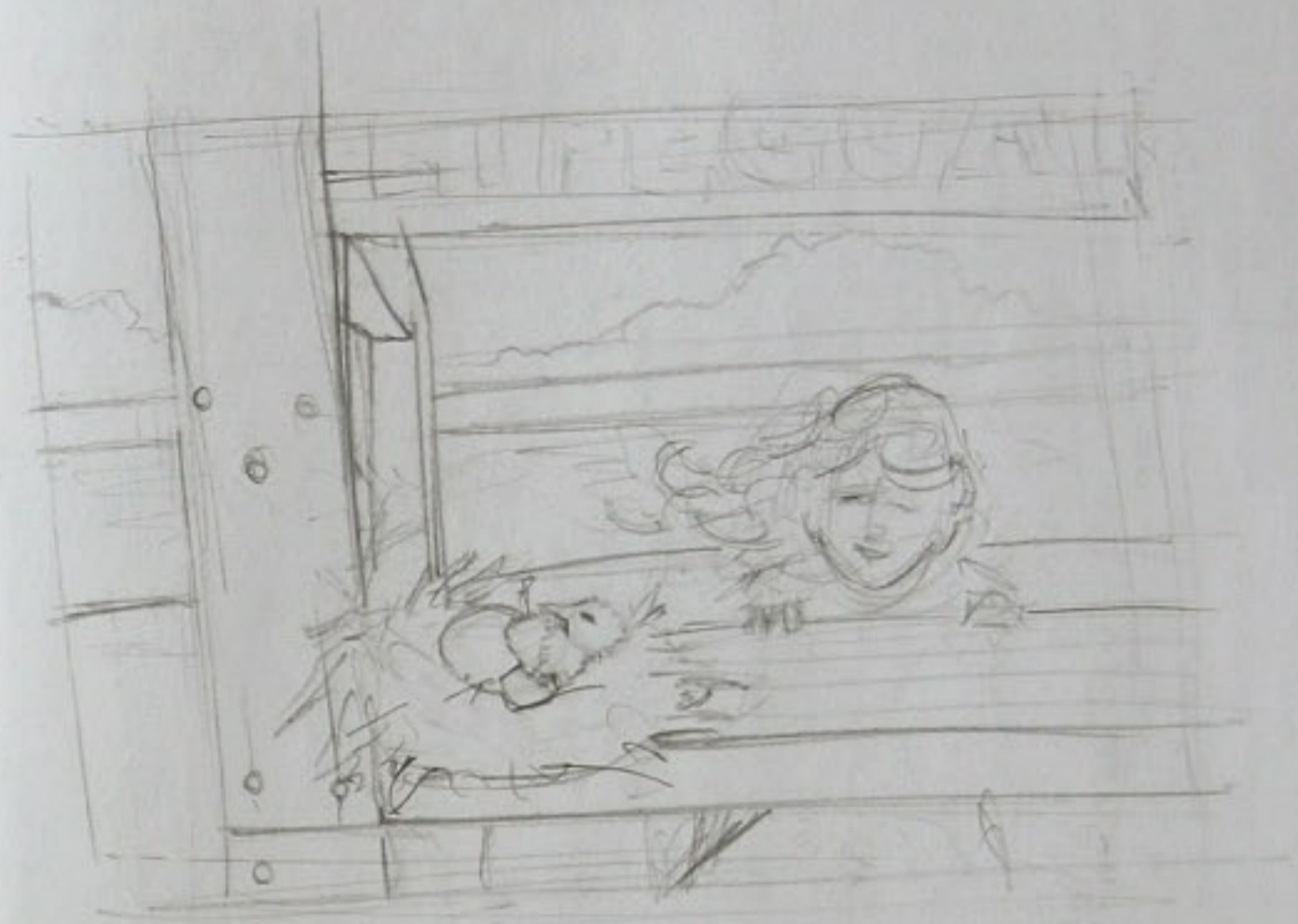
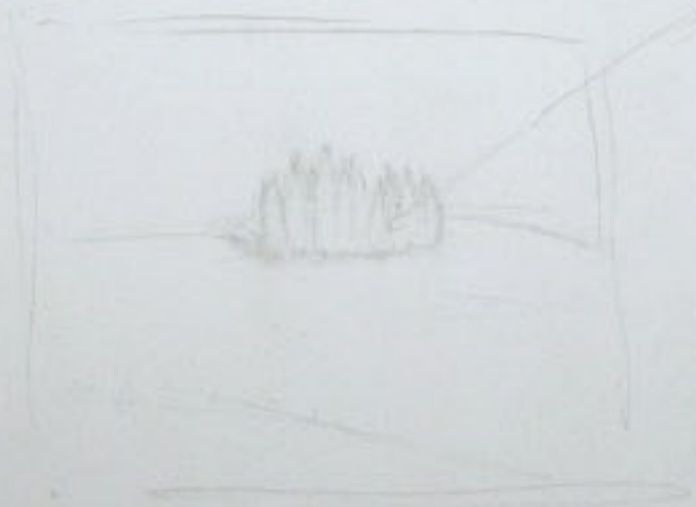

DON PAPE
 RANDOM HOUSE, INC.
 2375 TELSTAR DRIVE
 SUITE 160
 CALA RADO SPRINGS DRIVE
 PATRIMIA SPRINGS, CO
 PHILMEL 80920
 345 HUDSON ST.
 NEW YORK, NY 10014

CALL
KEVIN HINSON - 10:30 AM THURS.

PATTY COLEMAN
776-5075

W/PHOTO
W/VIDEO
W/TEXT

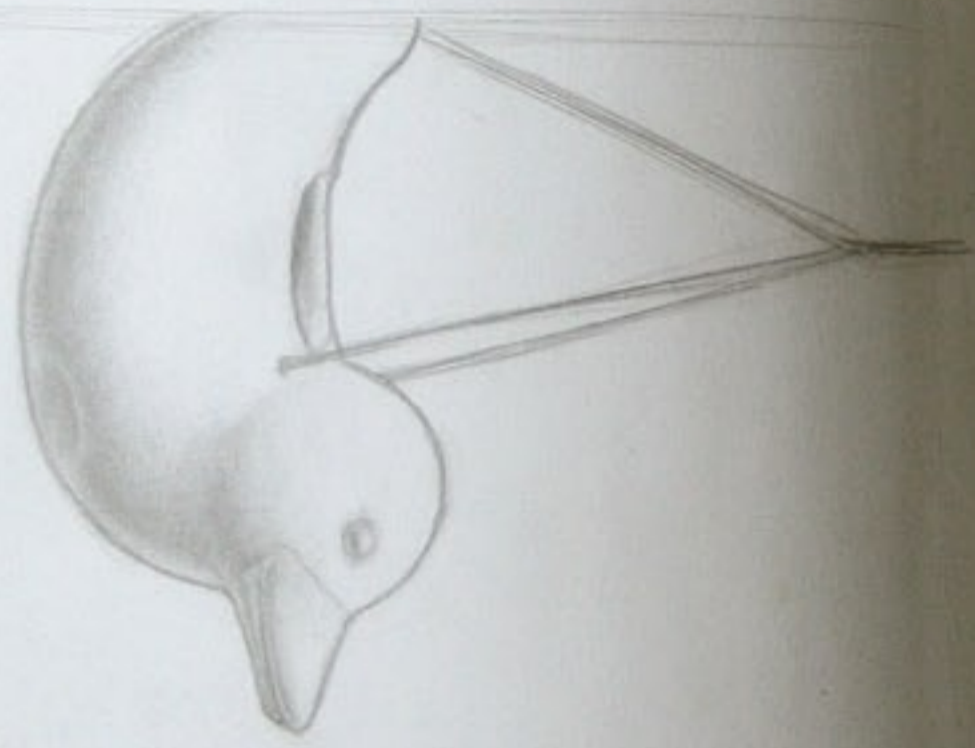

SITE
BIG ILLUSTRATION FOR IMAGE
CLIENT LIST

PLUS REP.
JOEL HARLIB

NATE BOUND'S BASKETBALL
TO THE BEST THROUGH ENTIRE
VIDEO. HE IS GOING TO GIRLFRIEND'S
HOUSE, HE CUTS THROUGH
PEOPLE, HOUSES, BEAUTY PARLORS
PET BREEDING STORES, EXOTIC
DANCE CLUBS, ROOMS, BOOKS
ARE OPENED & CURSED FOR HIM
ALLOWING HIM TO KEEP BOUNDING
BALL, SLIPING, DOING FAMILY BASKET-
BALL FOOTWORK & OCCASIONALLY
MARKET BASKET. FINALLY ARRIVES
AT HER HOUSE, WHERE SHE
IS STUNNED & GOES USUALLY
MADE UP & PRESSED. THEY
EXIT THE HOUSE, RAIN
RUINS HER WHOLE LOOK -
HE WIPES A BIT OF TIME
PANNING MAKEUP AWAY &
KISSES HER

CHASE
877 314 6353
0016056103

THUR 26 @ 10

TRUVOTE II
CHASE
800 310 4287
FAX
858 605 3823



- SINGLE IMAGE IN FOCUS
- CLIENT LIST W/PIA NAMES
- ANECDOTES

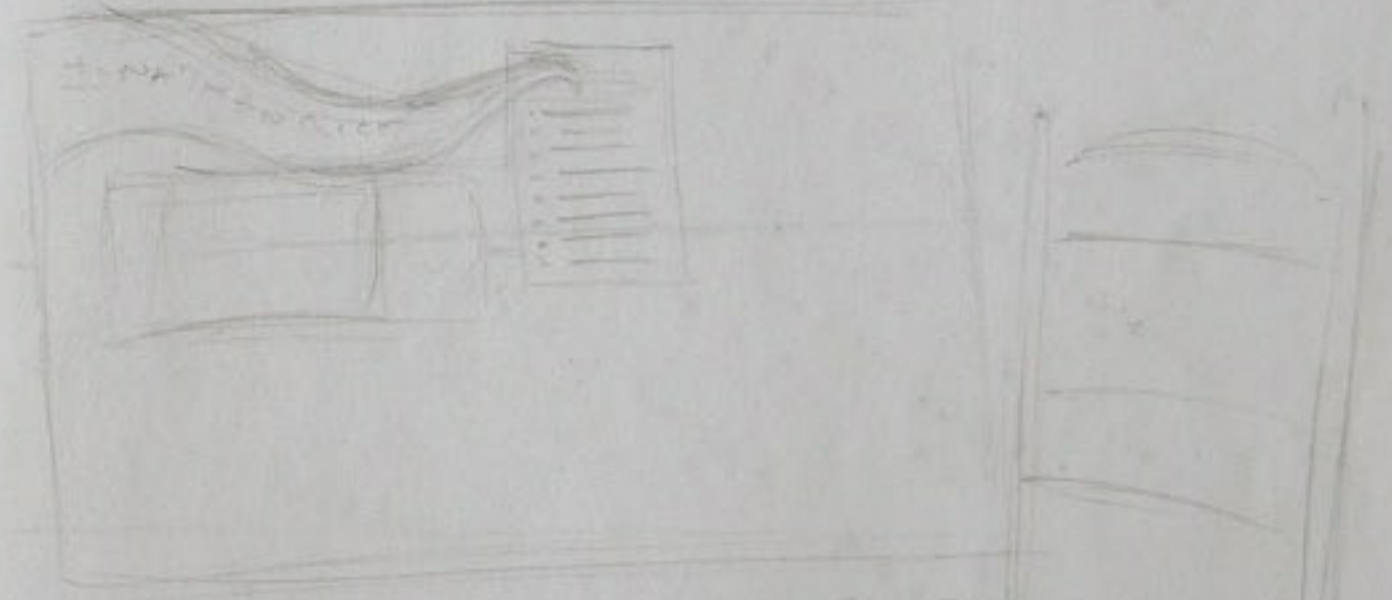

STARTS OUT SMALL @ WAVE BAR AND GROWS SLOWLY OVER A MINUTE TIME
TIGHTER CRIP, THOUGH

SPOT STUFF



STOOD
FLINK TO POLRAGE DESIGN
FLINK TO ORDER DVD

1 IN CORNER: IMAGE & IN TEXT

AMY GRANT



MARCSOOS & "THANK YOU BELGIUM!"

NEWSBOYS



SQUINTER LAND

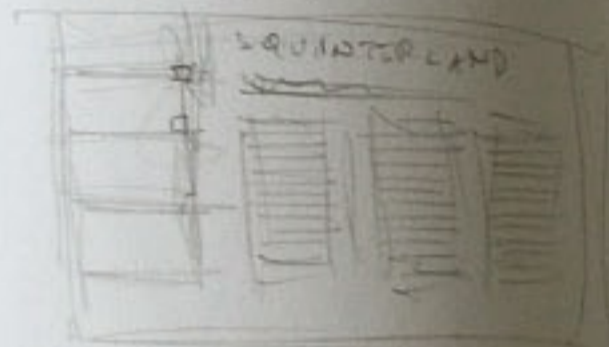

SHIRT GIMP



GIRL SCOUTS

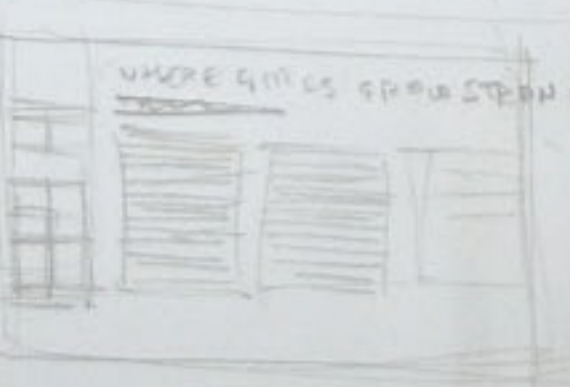

1/100

SCRAPE TOGETHER:
ENERGIZER?
CASH CAN
LEVIS & DOCKERS *
CITY GOLF (IAN)
WATER STUFF *
SQUINTER LAND VERSIONS
TO (EAT & PUT TO PUT UP

CHEWING &
CRUNCHING SOUNDS/K
ATLANTIC REAROS



FANATIC
CHRIS HARRIS

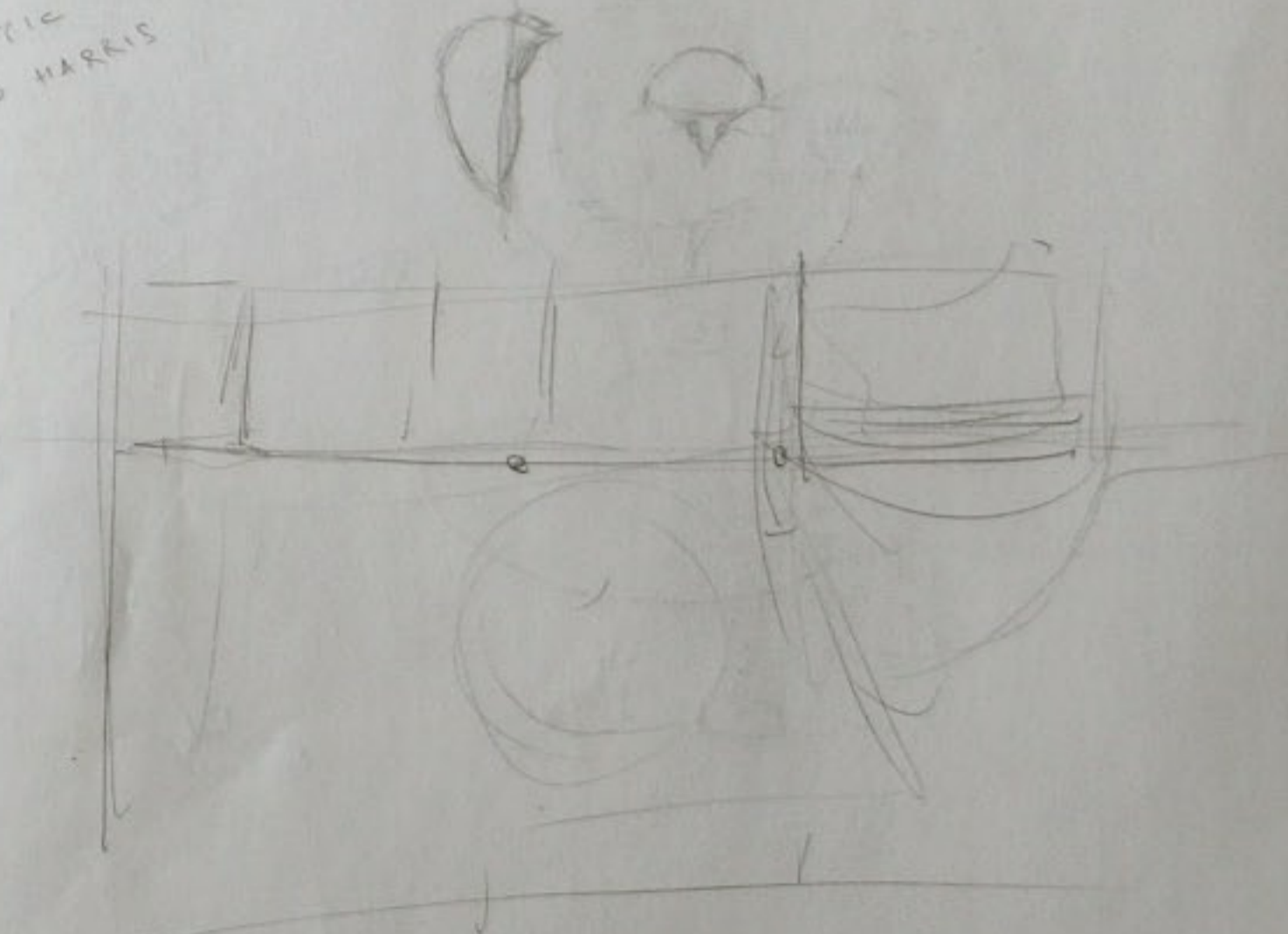

DIGITAL WELTON, NET

900

8/6 PARLONS

TUES

LYNN COLLECTIVE FILMS
CO.

PIECE 1409240

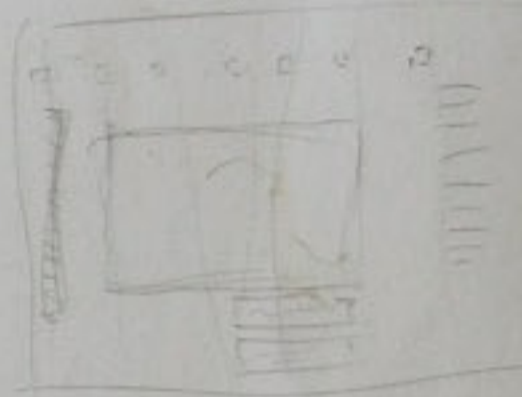

LYRICHEAD.COM

JASH MEL ABOUT E-COMMERCE RE: WHAT?

MARIE
CEL 405 5724

HAROWARE
BALL&BALL.COM
VANDYKE.COM

ED STRATTON
OMMA'S FLOWERS

| |
|-------|
| 10500 |
| 7500 |

1000 AE
1500 MAT*

M
13 CONVERSATIONS ABOUT
SOMETHING



JOSH JENNINGS - FLORIDA

(386) 788 1846

(123) 07

WILL SMITH
TOE@GENERAL-LIFT.COM



I CAN HURT THINGS!



VPS:
Y1A E72



1743 ELMWOOD DR.
CLARKSVILLE, IN
47129

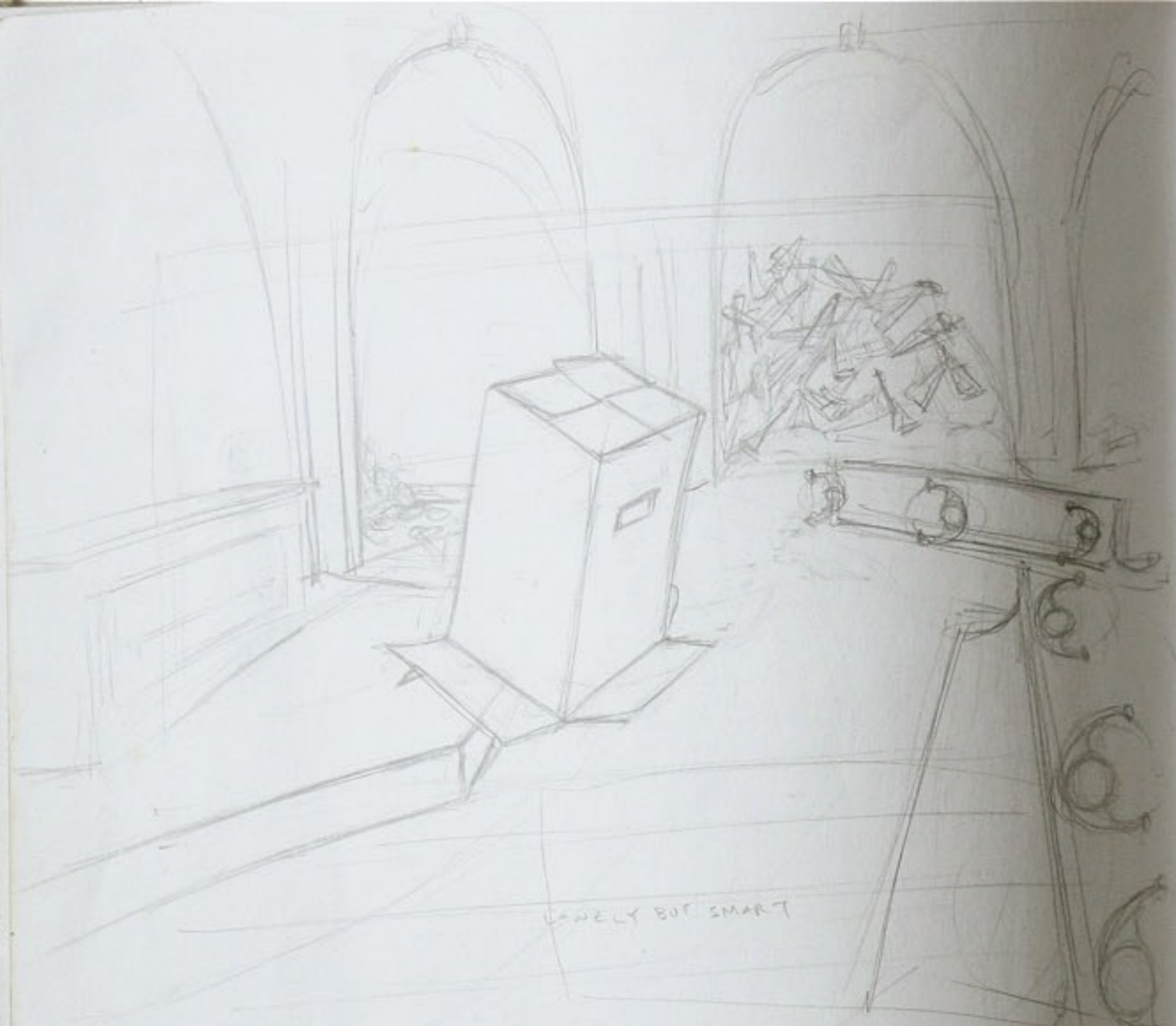

LOWEY BUT SMART

STEREOTYPES TO STEER CLEAR OF

- CHARACTER ← HOW THEY GOT THERE (MEMORIES)
- CHARACTERS → CORRESPONDING LOCATIONS
- PUPPET MECHANICS AS RELATED TO PERSONALITY TYPE
- THE ROUTINE — HOUR BY HOUR
- PERCEPTIONS HOW THEY RELATE TO THE WORLD
- CHARACTER INFLUENCE? (CULTURAL) ← SOLELY DERIVED FROM SURROUNDINGS
- IRREGULARITIES
- CYCLICAL REGULARITIES
- DIFFERENCES BETWEEN ORPHANS & NORMAL CHILDREN
- THINGS THEY DO FOR FUN
- VOICES

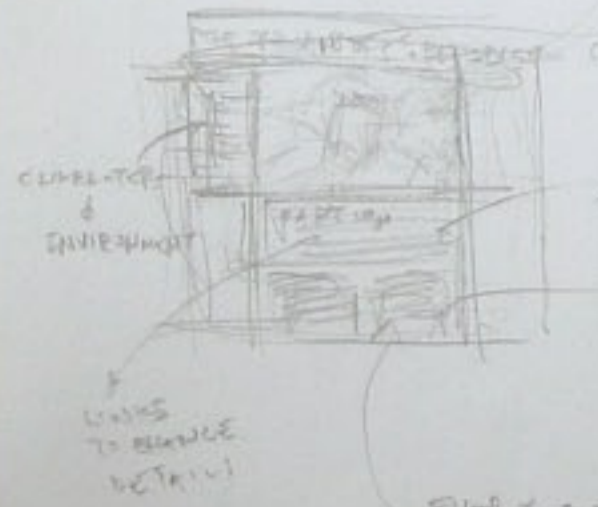

EVERY CONCEPT IS DEMONSTRATED W/IMAGE



FILE
2784566
L266
1302478

EXIT NO
3201



FILM CUTTING
STAGE



HA HA
EYES

ST. R. Y. B. ARVID. 2004



RT
1
2

Don't
+ like
+ hair

Don't care



CHINA

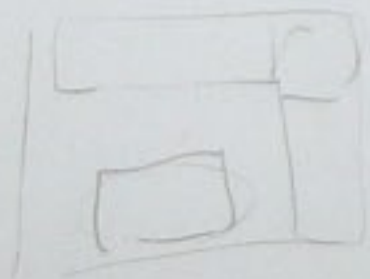
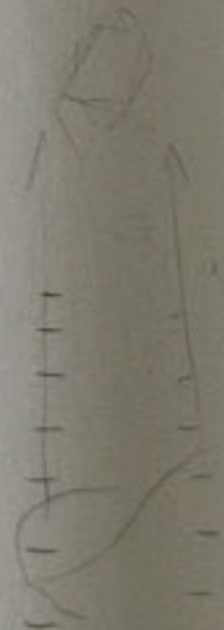
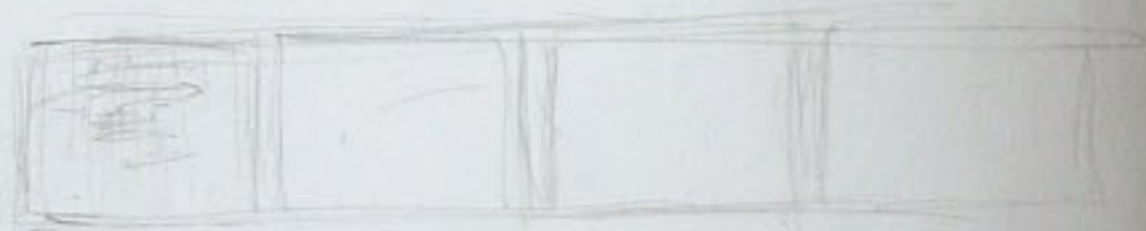

IFILM - NAZI DOCUMENTARY



ERY
ST
H
2
F

SPONS VIDEO

TIM JORDAN
952-1233

CHECK INTO PRICES FOR AUTHORIZING

SLOW IS THE NEW FAST

SIMONS & GRUNKE
ORGANIC &
ELECTRONICS

FLOWING

DI CULTURE
MEETS
ANIMAL FARM



4063

836 PM

TAN
HONDA
ADDRESS

300

250

250

800



LINTY

ONE WORLD SOUND



Producto de la Agricultura Orgánica
Certificado por ARGENCERT SRL
Inscrito en el Registro SENASA N°96

CHILCA RUE IMPRESOS T. 424215

WED

LANGUAGE TRAIL
 5
 16x16 BMP
 15 TEXT TRANSLATION
 15 SCREEN TOUCH...
 15 (MUSIC REELS... "SAY...")
 15 (GAG W/ST 16 RESURGE)
 15 DONE

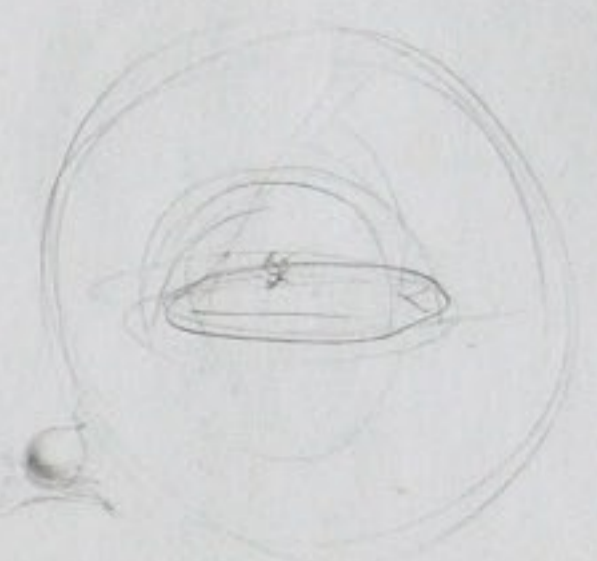

NOT TRUSTING
 NERVOUS
 LASER TAG GEAR

SONG FOR THE
 ASKING

2. THE APICALTA
 ANIMAL FARM
 UNLAD JACK ON INSIDE
 OF WINGS/SEAN CONNER
 BRITISH EAGLE

CONFIDENT
 FALSE
 EXTERIOR
 FEEDING DONKEY

GREAT HOUND
 MULLER LONGET
 HAIR

DRUMSTICK
 BUILT INTO CAUL
 ARM
 THOUGH

SWORD
 FLAMES
 LIFE'S
 HARD
 WHISKY
 GLASS
 CONSTANT
 TALK

30-20 200 TAYLOR
 WHISKY DEER-HAT

DISTORTION
 CHEETAH



BLACKPANSY@LEFT.COM

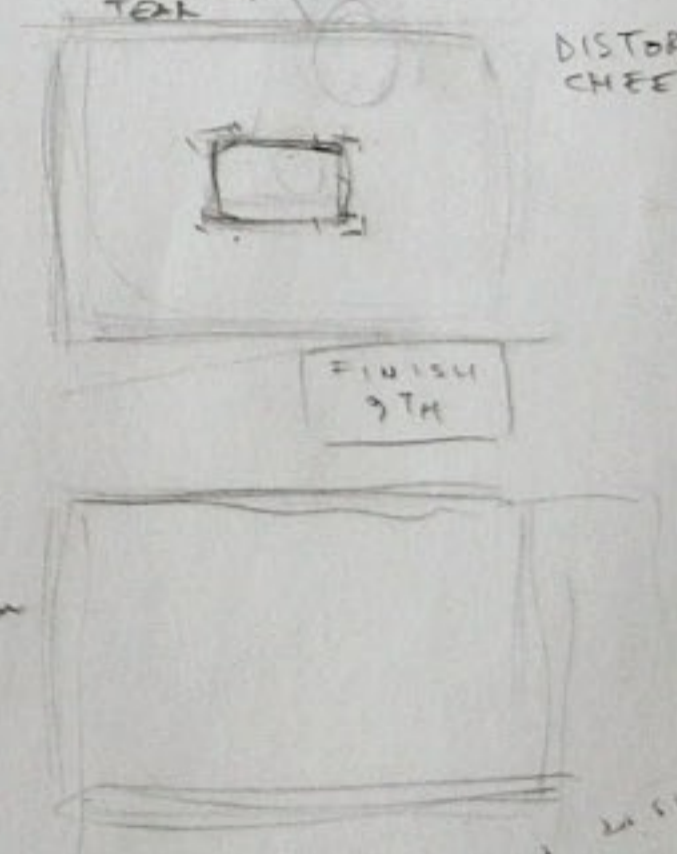

1833
 RECORD FROM 15 MILES
 (SIC R X P)

- 1 BABY IN CRIB
- 2 COB SCOUT W/ARM IN FRAME 6/TROPHY
- 3 LITTLE LEAGUE
- 4 GRADUATION
- 5

ANDRE'S
 HERE'S
 CITY OF GOD

BACKSTORY



THOUGH
 ACT 1
 ACT 2
 ACT 3
 THOUGHT WAS CAL
 THINGS ARE UNUSUAL
 RELATION @ ACT 2

- DIGITAL INTERNET
- UNCOMPRESS FCP
- WIRELESS MONITOR
- DEPTH OF FIELD IN HD

THE LEWIS
 DOWN USE
 FIN TARRA
 MUE BAVEL
 IAN COURT/BILL KAMMERER
 DAN KAMMERER

FILMWORKERS
 312 664 7333
 CHAD

\$1250
 NELSON & CAFE
 1045 SEC INTRO
 NO SET

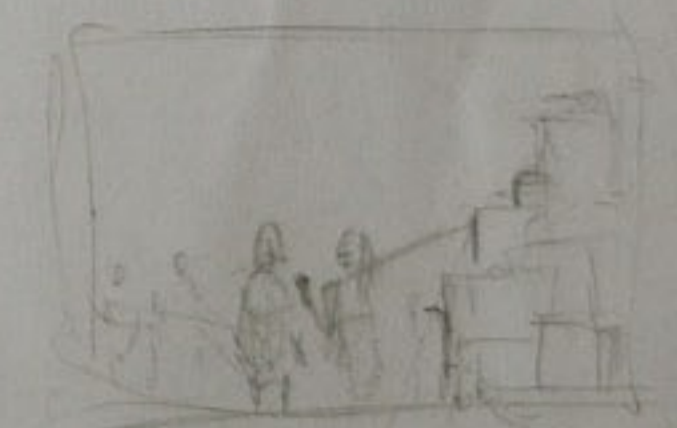

You will be coming into a fortune.
 06 10 26 31 45, 9

KABALAH

TEACHER
PHYLLIS PILLAR

(FRUMPY) ← LITTLE ALIEN CREATURE
6-8 INCHES TALL
PINK

DAVID BAWEL
(310) 822 9543

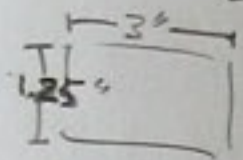

DAVID
ARTWORKS, NET

GREEN
NAME
YELLOW

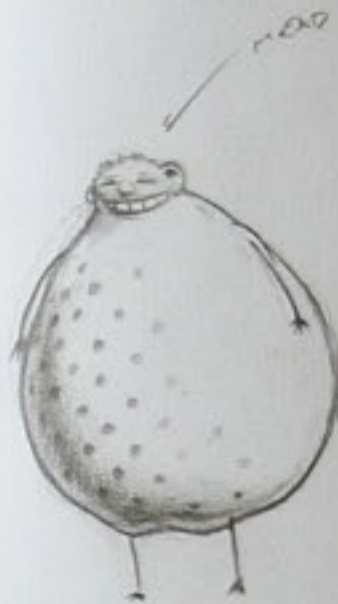
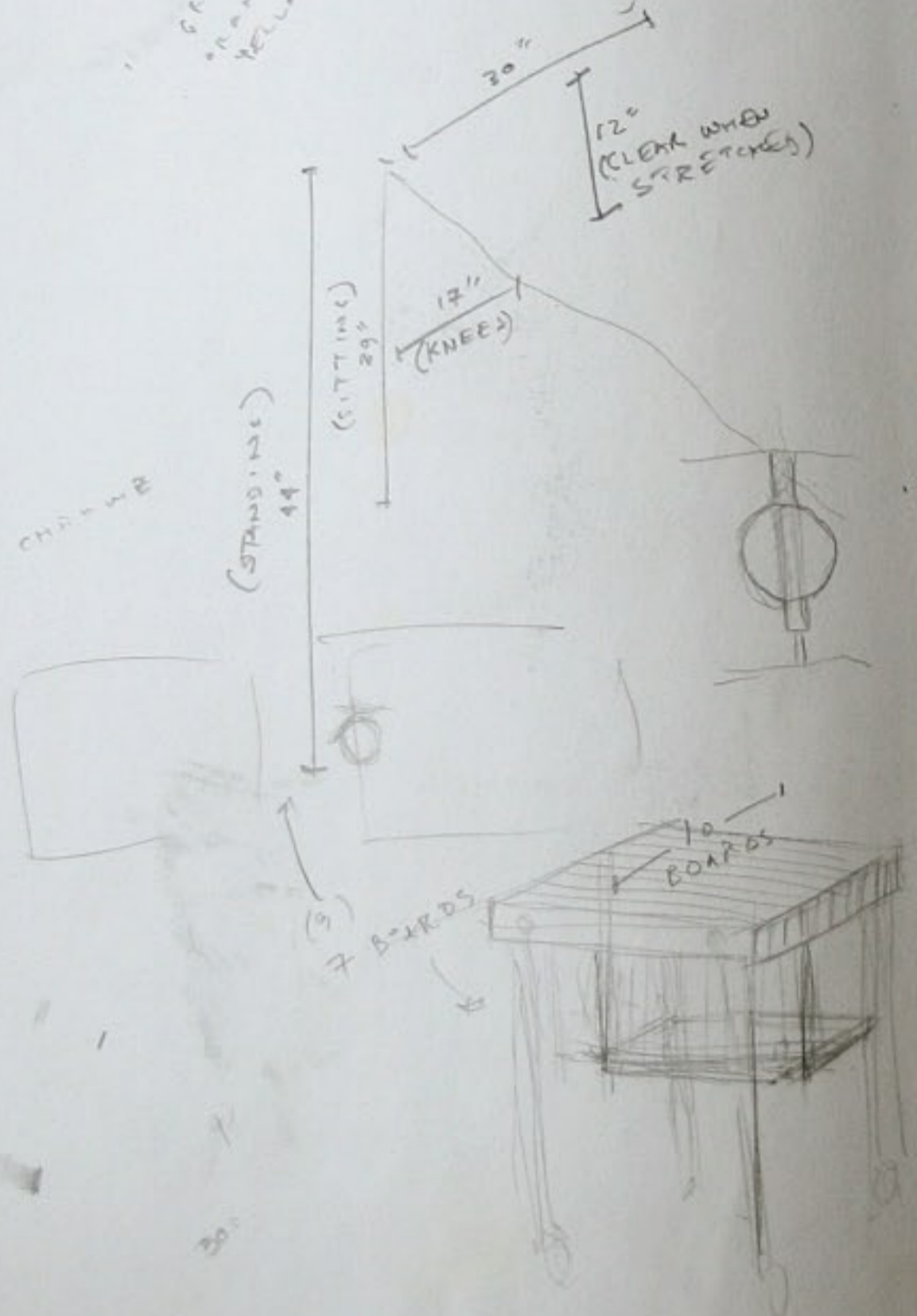

ORDER THE BOOKS
INSURANCE

TREE FALLS IN FOREST

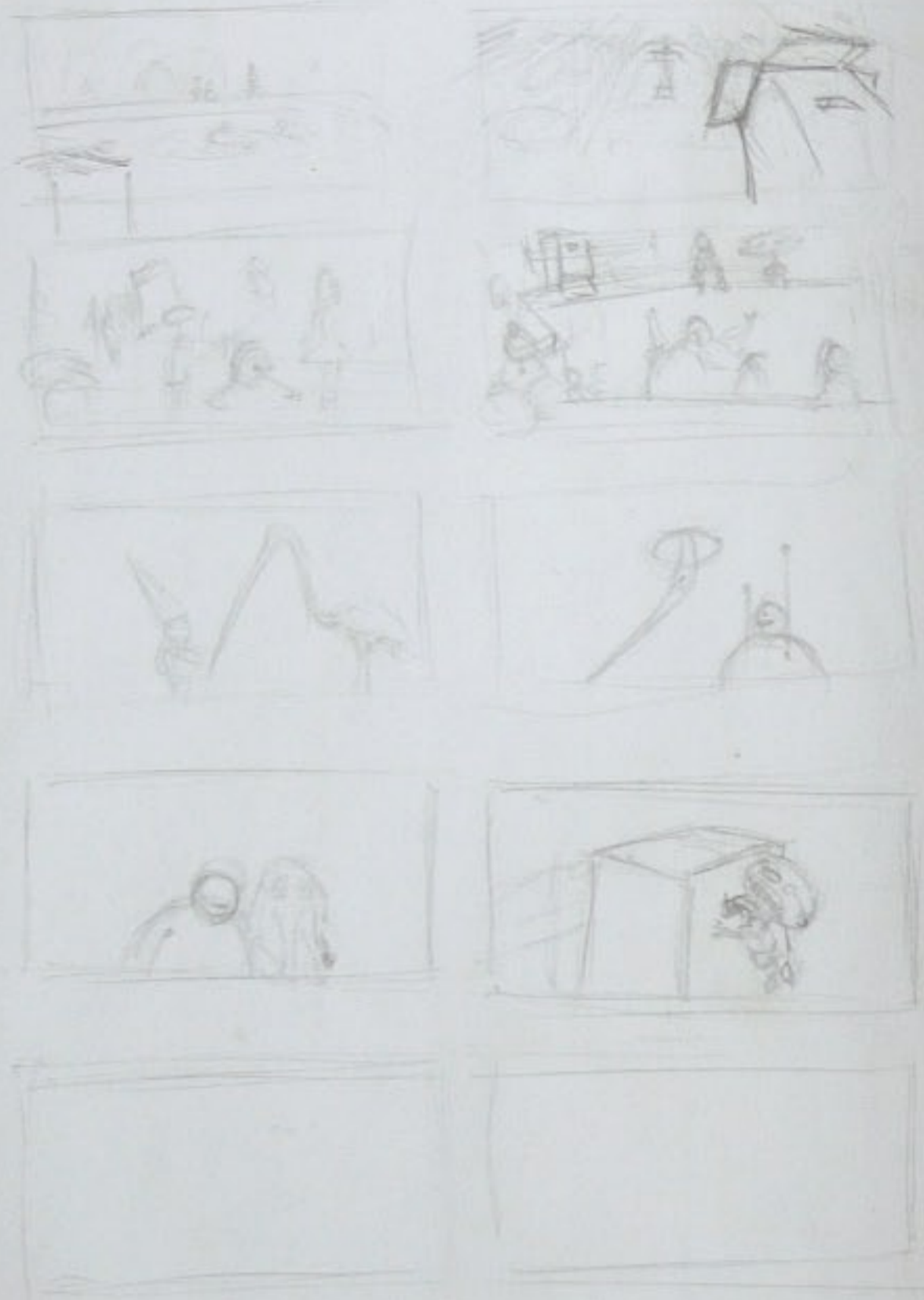

931-734-0007
OSASGARDEN.COM
LRA@OSG.COM

LLC
C-CORP - TWICE TAXED
S-CORP & SHAREHOLDERS TAXED ONCE
LLC

16

CAROL PRASIER
297911
423 3214 cel

DECEMBER 14
DECEMBER 12

JUNE
17TH
@ 8:30 AM

25TH
2:00 PM
@ 8:30 AM

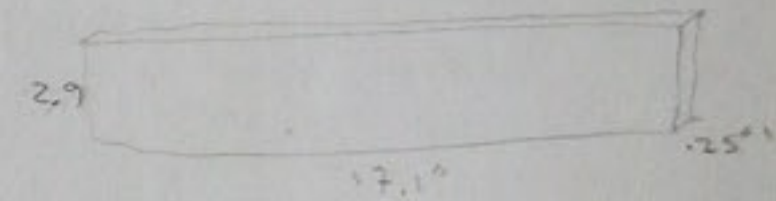

AATON 400 FT
LOADS



- DSC #15
- "THE" SECOND CHANCE
- ✓ (CP) MOVIE PAGE (P.1)
BIG PICTURE SUMMARY
THE PROJECT
- ✓ (CP) REPLACE SHOT OF FRANKLIN
GEMAN
WITH BONO SHOT
- ★ (CP) DATA BIT (BONO) UNDER
CAREER HIGHLIGHTS
- ★ (CP) UPDATE PASSIONATE INFO
- ✓ (CP) FILM CHARACTERS
FIND NEW PHOTOS
STILL VIDEOS
- ✓ (CP) SECOND CHANCE LLC
- ✓ (CP) CONTACT INFO LAST
PAGE

5/2 9326

TAUR 200
VANDERBILT
615 322 3475
LAB
313 9155

NEED: ROPUS DISK
(BAR CODE #3800000000000)
JAVELI LOGO
1.0 ENGLISH/CELESTIAL
FOOT
NO. 13 GRAPHIC



- SINGLES BOLD

KEY TO TX

- SIMPLE
- PAUSES BETWEEN POINTS
- DIRECT
- MUSIC STOPS BETWEEN INTRO & OUTRO

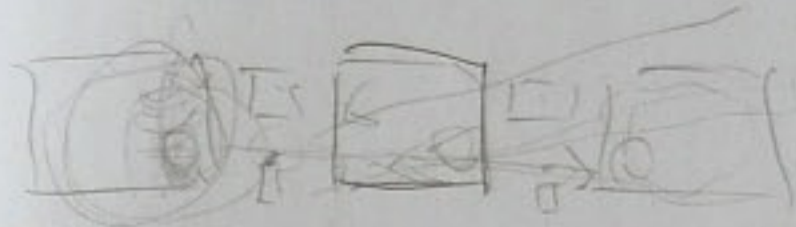

BEHOLD
FRANK FRIDAY
THEIR
FINAL DESTINATION

- AMORPHOUS ANIMATED SHAPES → BOOK-LIKE → TRAVEL GRAPHIC SHAPES ANIMATING INTERACTIVELY WITH

- 2001 SPACE ODD + 3 SET AT VERT BEGINNING

THE NOPE

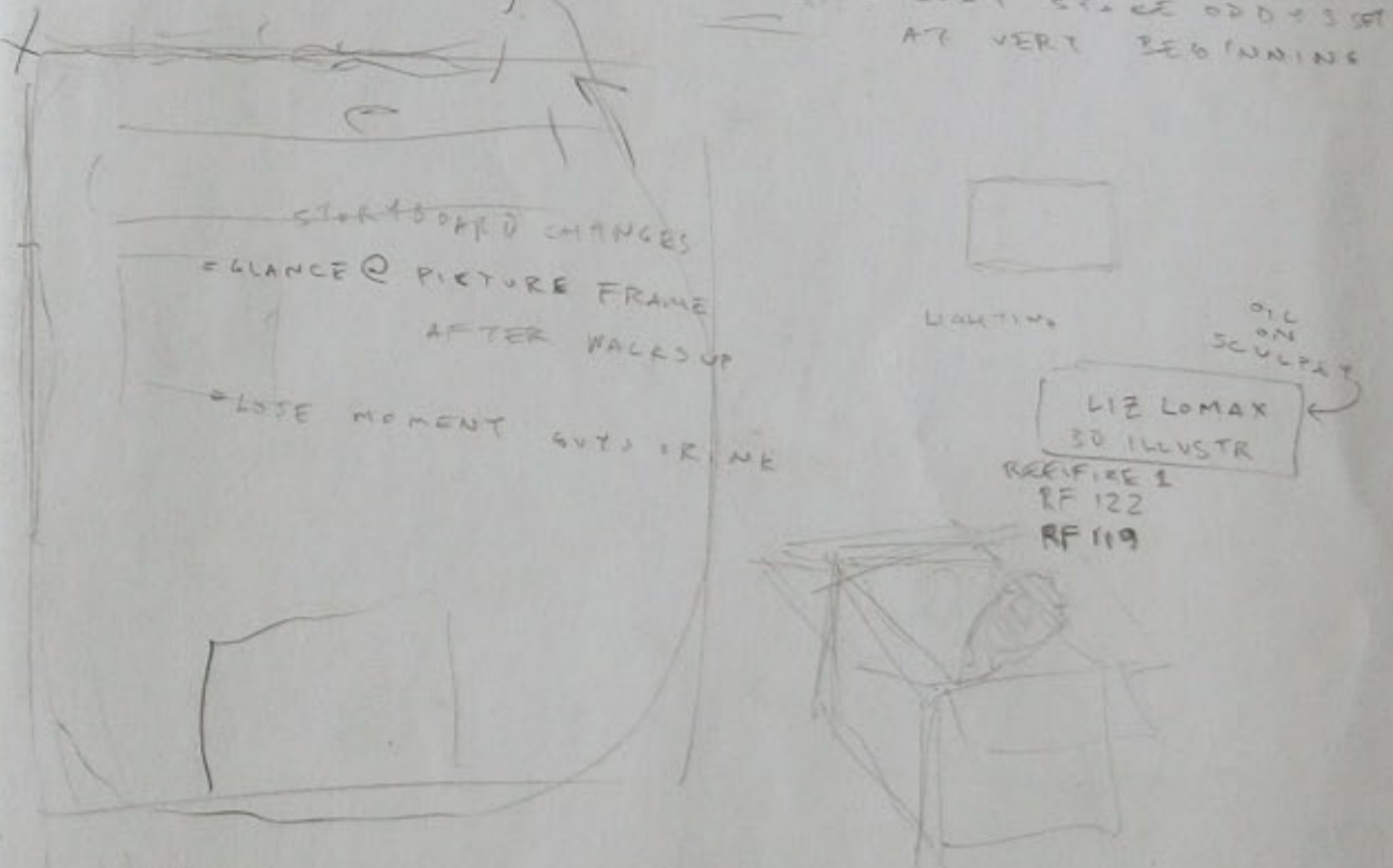

Books

- 1 RAMP INSTEAD OF STANDING STILL
- 2 FLASH COVERS INTO EXISTENCE
- 3 MOVE COVERS IN FOREGROUND → RIGHT
- 4 PULL FOCUS TO FG BOOKS

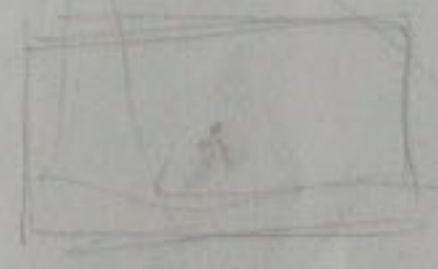

"INSIDE YOUR OLD LEFT SHOE?"





800 432 1000
S 13 805
4021
PAT DELGADO (SOUTH TAMPA)
ACCT# 00000037817
02857
011 593 2 889539 FAX

THE DRUNKEN
DREAM OF
THE GOALKEEPER?

800 444 8510
618 463 284

1000
800
600
800
800
120

- PAY \$2000 TO B-DRY
- FIX FRIDGE & WASHING MACHINE

MICROWAVE (HOME DEPOT) 10%?

- FIX GARAGE DOOR
- GET 300# FOR BOFA

- BUFFALO IN MATA
- MAKE WARE
- NEW DVD REELS



2500
1500
2500
400
11700



CONCHA Y TORO?
PANELA
VANILLA

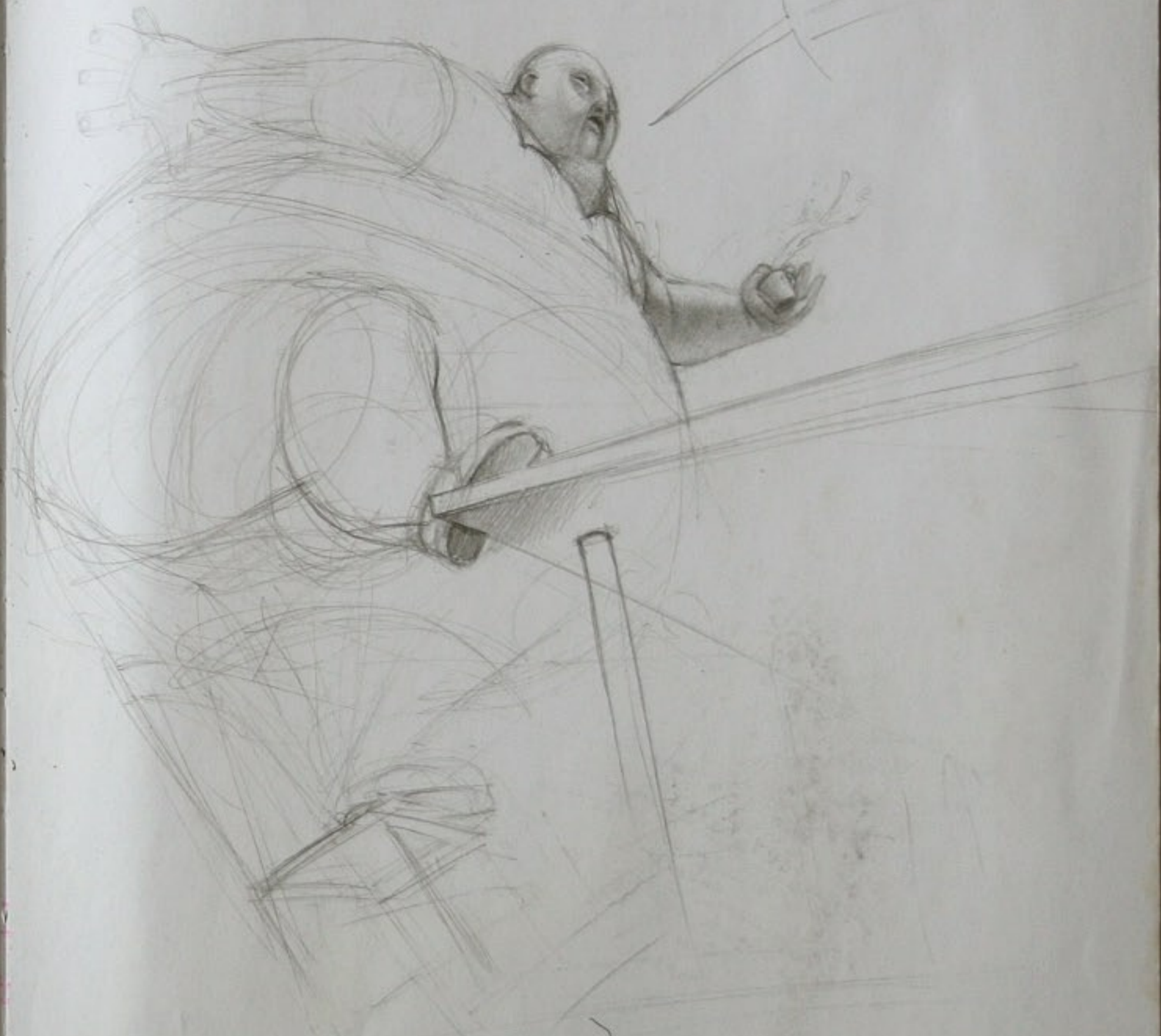

PR

20

20 FEBRUARY

HEIGHTS
EPIC
LAWYERS ROAD
BEAUTIFUL

40 → EXIT 47A
JEFFERSON AVE
ELLINGTON PKWY
1416 EASTLAND
CLEVELAND
CALVIN
EASTLAND
(OG HILLS)
N 15TH & EASTLAND

CEO
VES
724
3016



1000 1012
1013

SISK
CHRIS LONG
385 1100

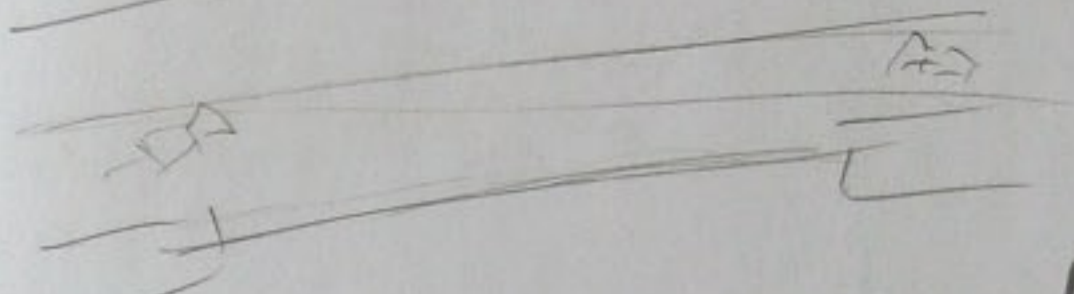

101



REFER
GOOD
NEW YORK
GOOD
RELEASE
WILLIAM

QUINCY
PROFESSIONAL
SERVICES

CALL DUART

4007
S-FL-
11:23:11
11:23:29

MILLIONAIRE
CORT
293-2375

Film TITLES
TO REFERENCE
LOTTERY
I.P. CALL LOTTERY

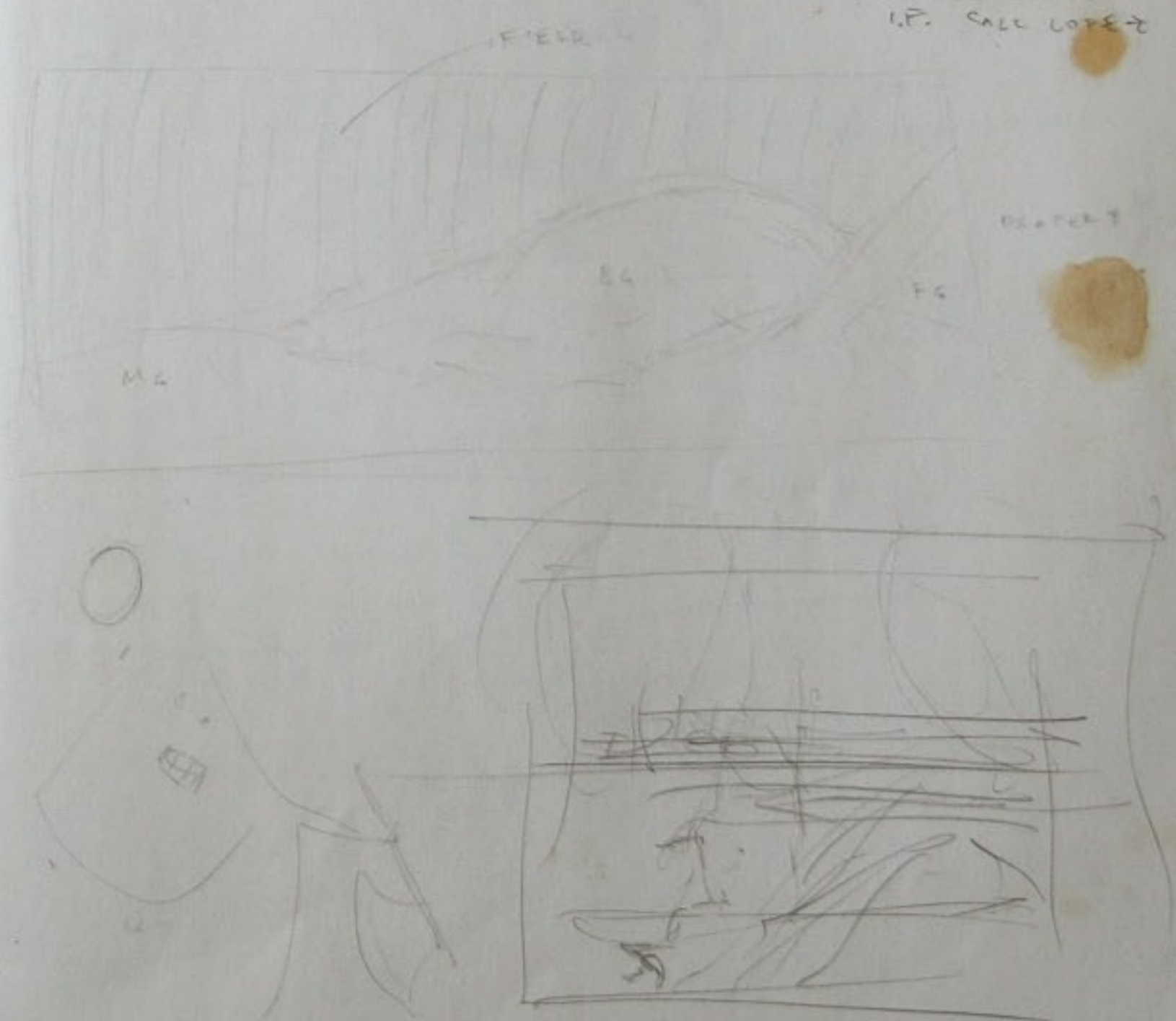

- GIRL MORE IN FRONT
- HIDE FEET IN BEHIND GIRL SHOT
- FADE UP HILLSIDE SOONER/SLOWER
- HILLSIDE DARKER/SATURATED

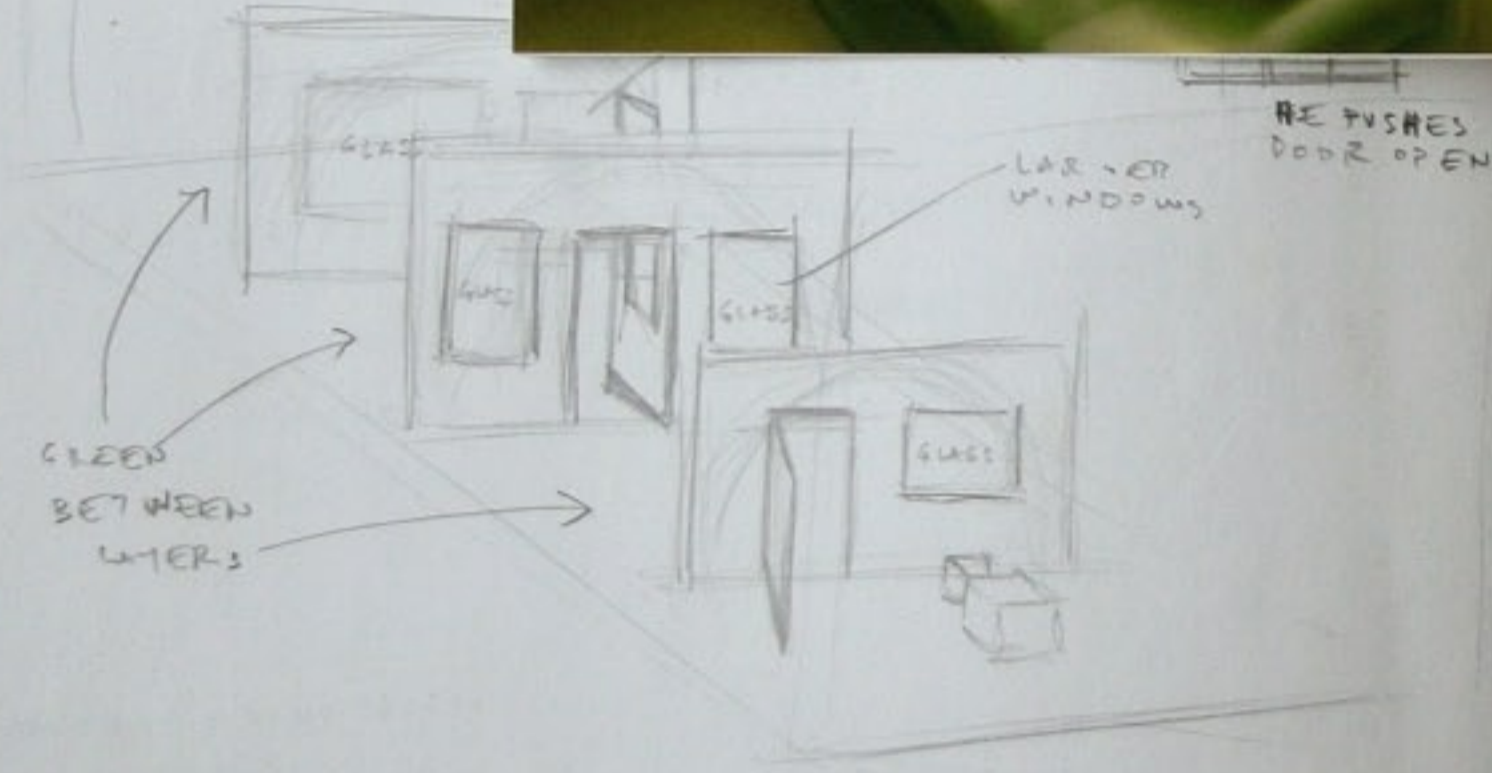

PARTS = LIABILITIES = EQUITY

DAVID
60 x 02 58

- NEED TO SHOOT - USE OF CAMERA
- DRIPS
 - SPLASHES
 - BUFFALO DUST (PARTICLES!)

- HAT DRIVES SO
- REALITY W?
- REAL CLOTH?
- BETTER?
- ETHERNET FASTER

STEVEN MALK
SMALK@WRITERSHOUSE.E.COM

CHRIS WELCH
BROKEN POET
OFFICE 791 7863
CA 364 7069



- REV'D
- PRELUDE - TALKS
 - DUDE & RIDES
 - JOURNEY
 - CHILDREN
 - BIKE PARTS
 - LEATHER
 - METAL PLATE
 - DIRT
 - NO RUST
 - SMALL ELEMENTS
 - RPM
 - TATTOO
 - JESUS W/ THORN CROWN

- 1 NO BIKE
- 2 TATTOOED MAN (MAGNIFY)
- 3 CROWD IN CITY
- 4 CROWD @ NIGHT
- 5 DRIVING INTO CITY
- 6 DUDE WITH CROWN





GET WINE STUFF
GET FARKS, PLATES, NAPKINS (FOR GO)

CHRIS RICE
SHOWING COFFEE - FLAVAT LAY - CLUCK
"HE'S CRAZY - HE'LL DO ANYTHING!"
CHRISTIAN CAMTEOUS
SHORTS T-SHIRTS
DECEMBER 8

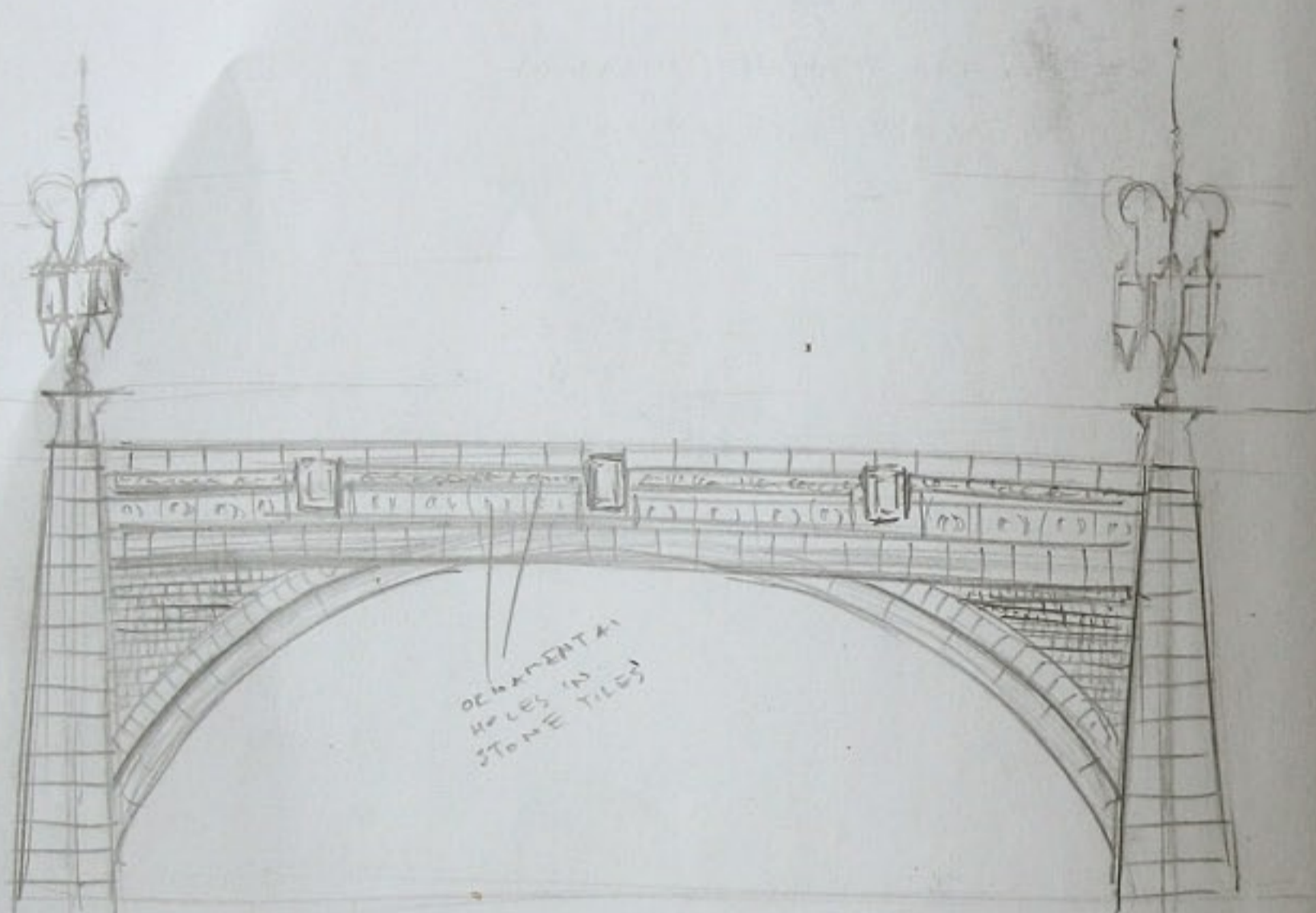

LA M P U S . R O .
MONTBANK
MONTBANK
MONTBANK

30 DRAWINGS

15

BAO@THEBAOWAY.COM

ADD TO WEBSITE
HEALING INTRO
DREAM TRACE
EDITED BRIDGES

JIM MAY
779 4429

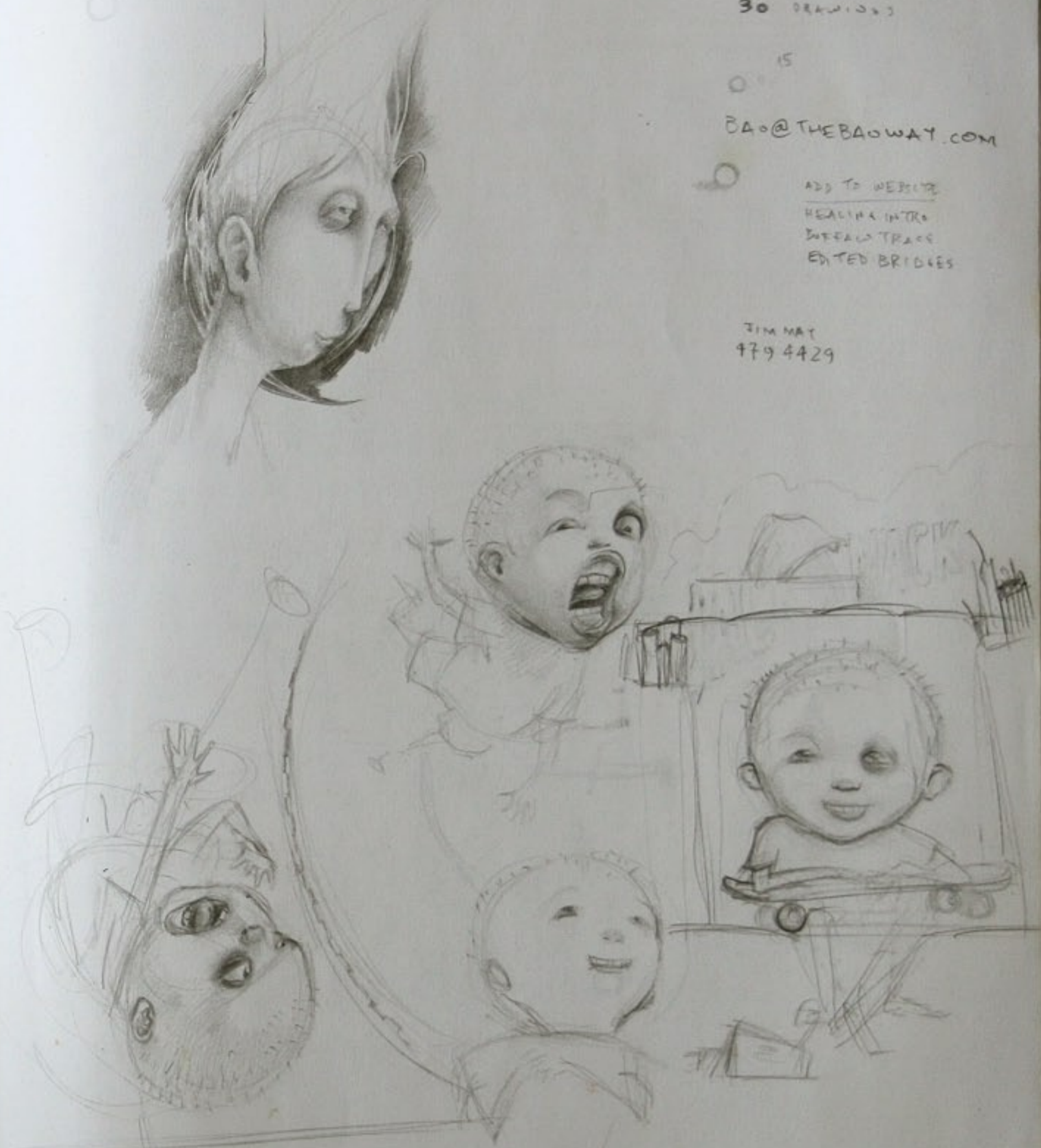

T-PI WISS #L
M 818 293 9654
212 361 1678



51
1957
EPC 57



LOLLY,
THE WISE
BEETLE

SAUCY,
THE FRIENDLY
LADY BUG

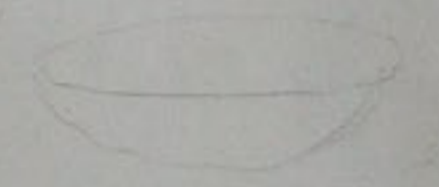

RUBBERSTAMP OF NAME

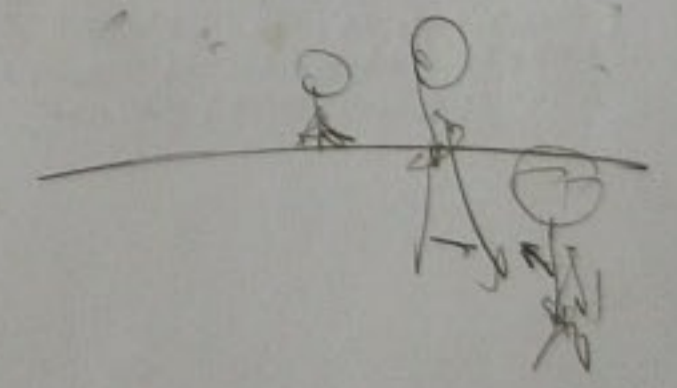
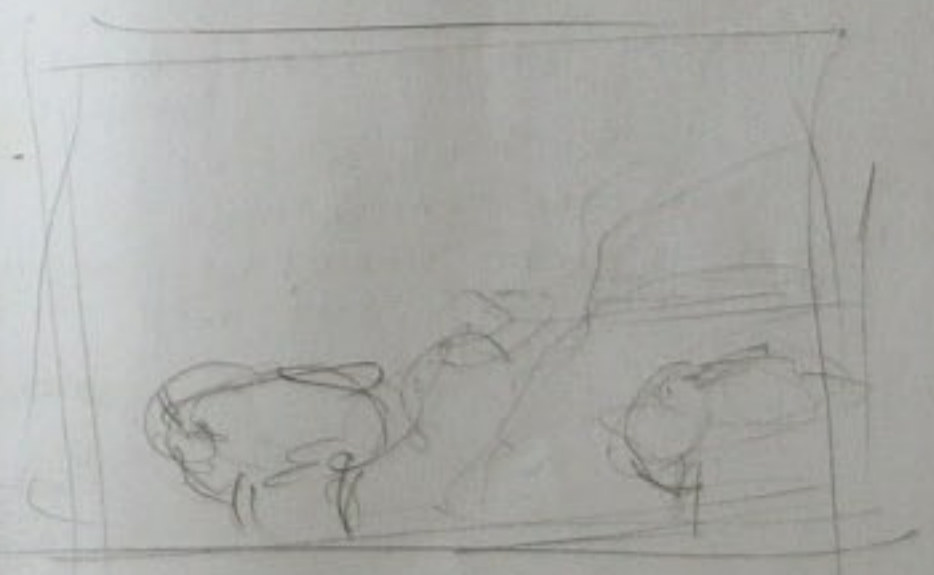
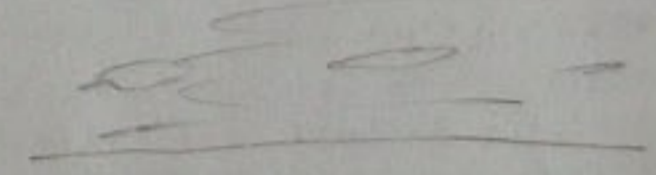



A BLAZING GRACE

INDIVIDUAL IGNITION / KINDLE
 CHURCH STOKING / FUEL
 FAMILY TENDING / FAN
 WORLD FANNING / SPREAD



A BLAZING GRACE

A BLAZING GRACE
 A BLAZING GRACE

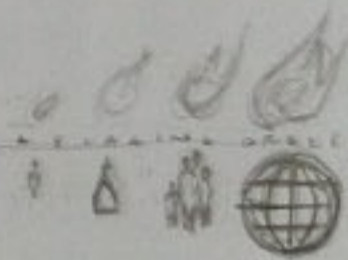

FRAMEFORGED
 0270



- simple sequence; illust. of how it works; on the side or back.
- vintage "idealized" illust. of toy on front.



21x
323 7994
5016m 1514

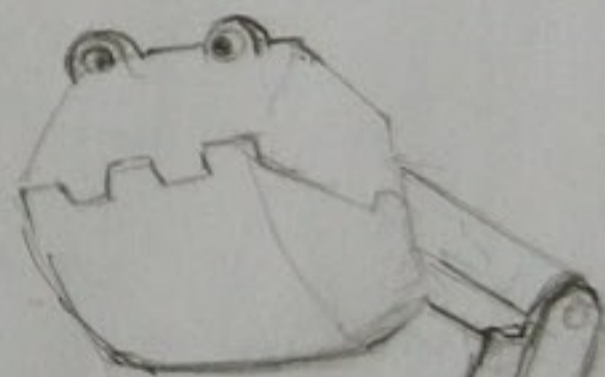
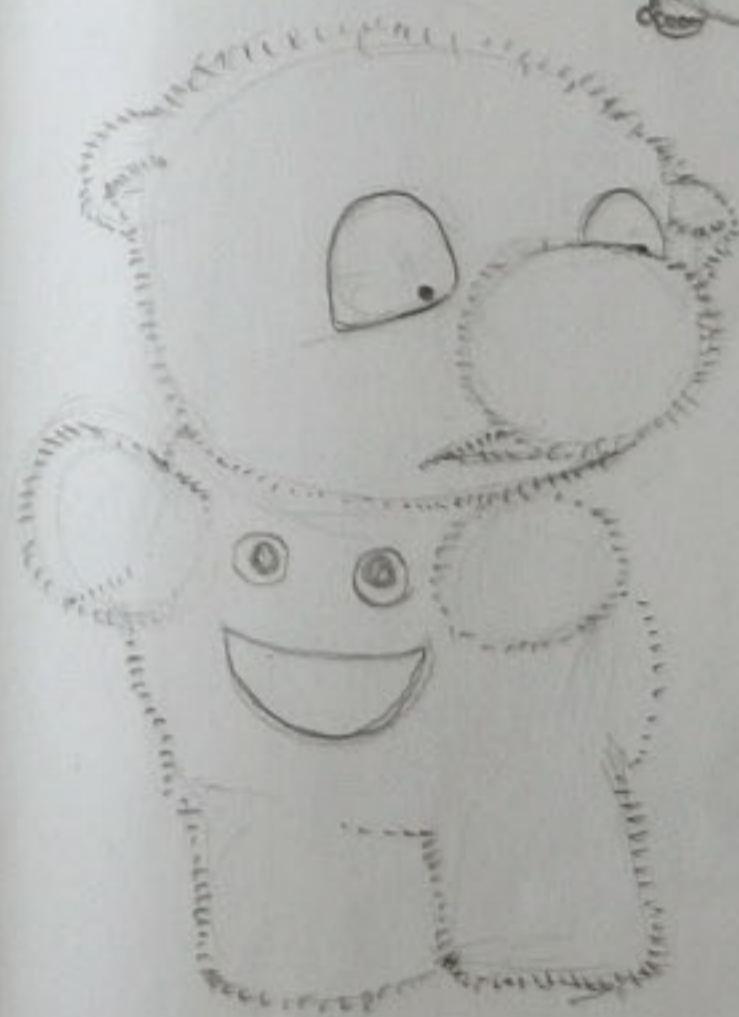
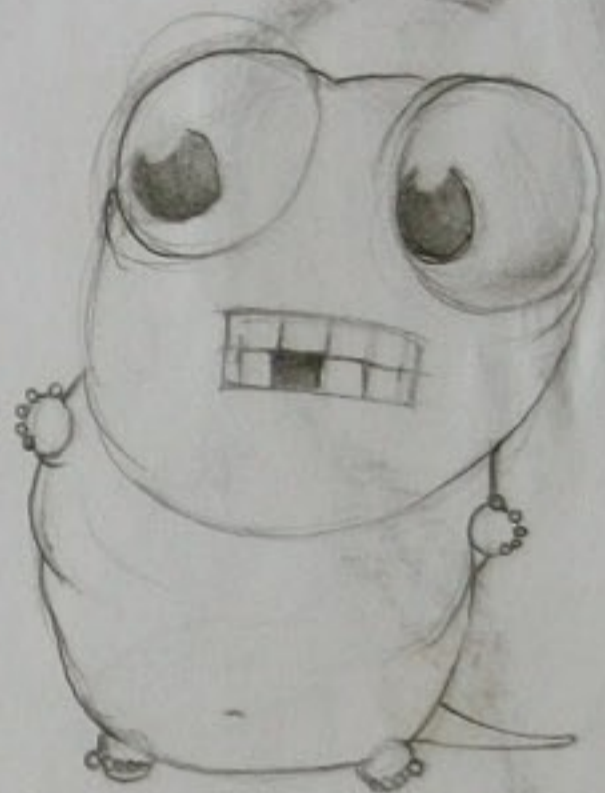

HAIR
SCRAP

TAKE OSCAR
FACE
SCRAP?

GLASS
SCRAP

TREE HANDS
SCRAP

ORANGE

COOKIE
SCRAP



↑
O
BLUE
WHITE

2004
K
5/3
FLIPSCRIPTT@AOL.COM



I'M CRANKY TODAY

HOLY CRAP - HE RIPPED OFF RYDEN WITHOUT
KNOWING!

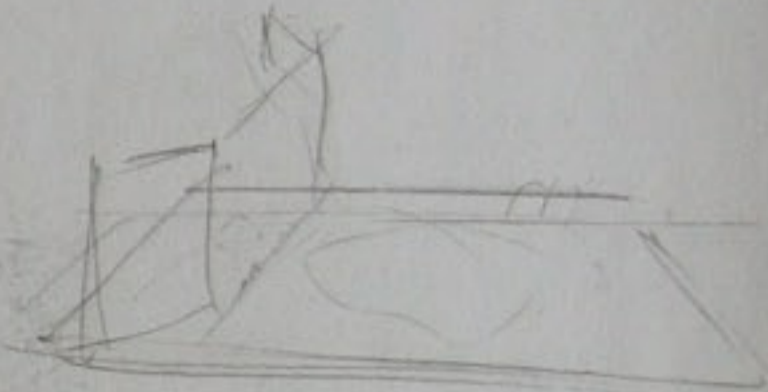

COMPASSION MWS
FLOOD WATER MISSION
INTEGRITY
INTEGRITY

LAND BOTTLE SHOT
VIGNETTE OR HALF BOTTLE

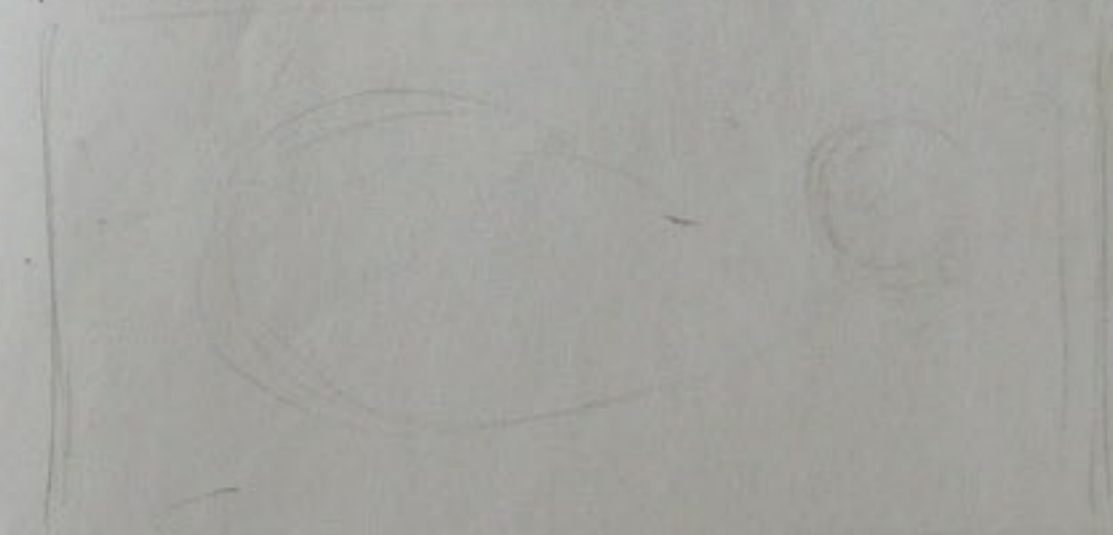
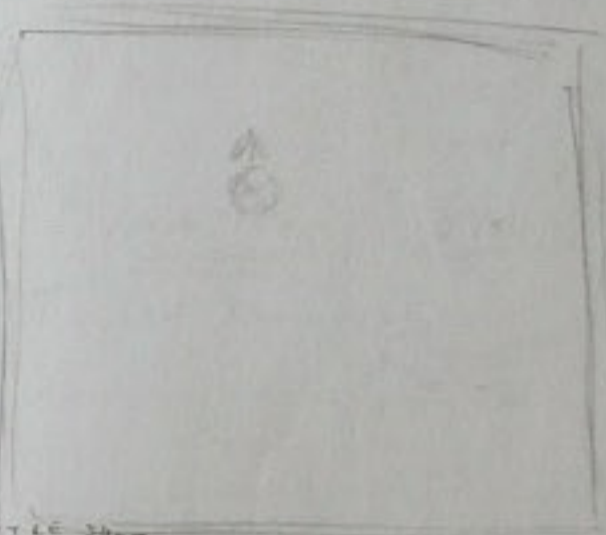

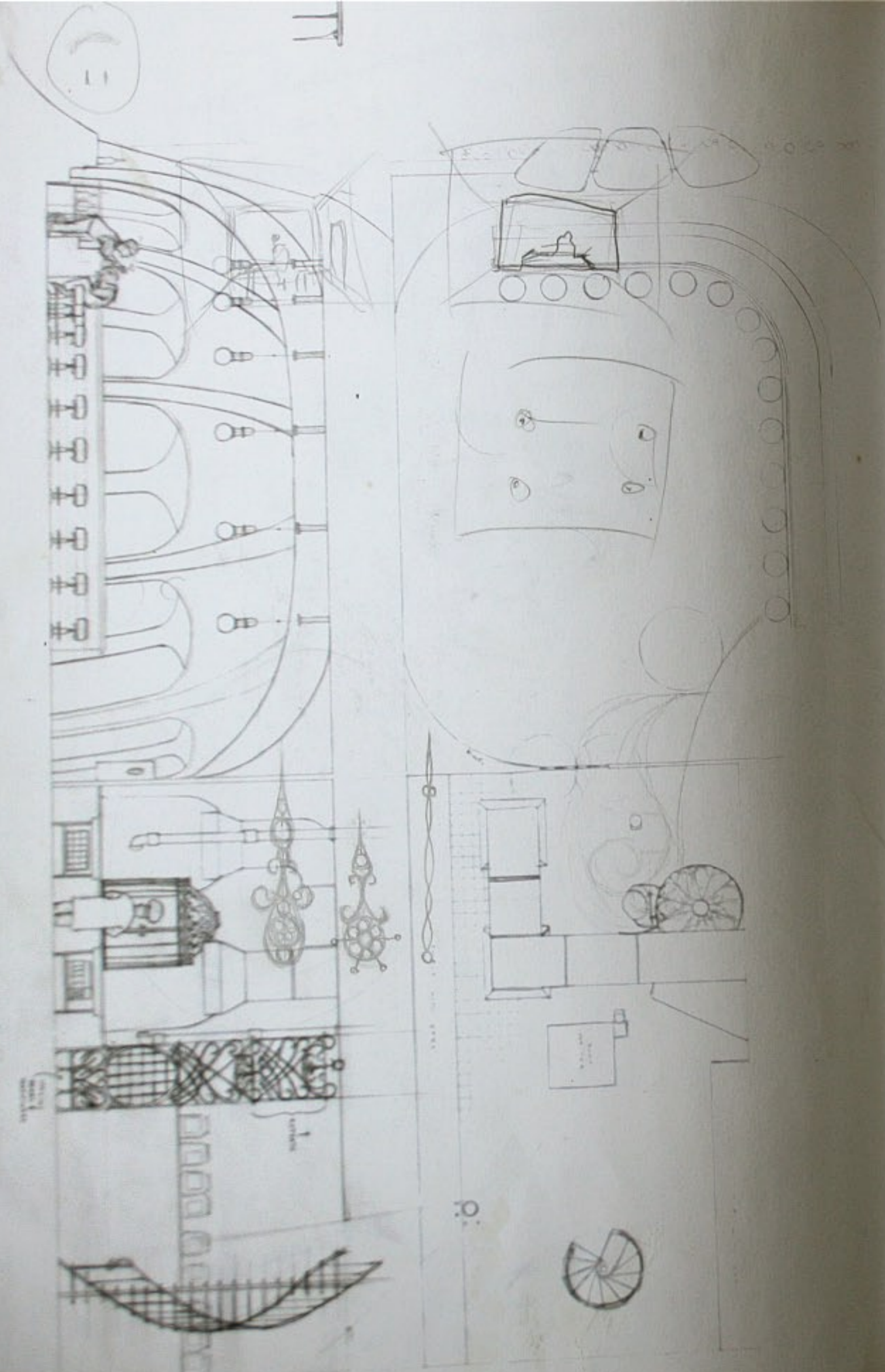

3 60
 3 180
 500
 270 HOURS
 6 36200

SHOOT TOES 5TH DRUM
 00:03:00

DELIVER APRIL 1
 TOUR STARTS " "

THOMAS
 SPECIAL ADMINISTRATOR
 BECOMES PART OF FAMILY

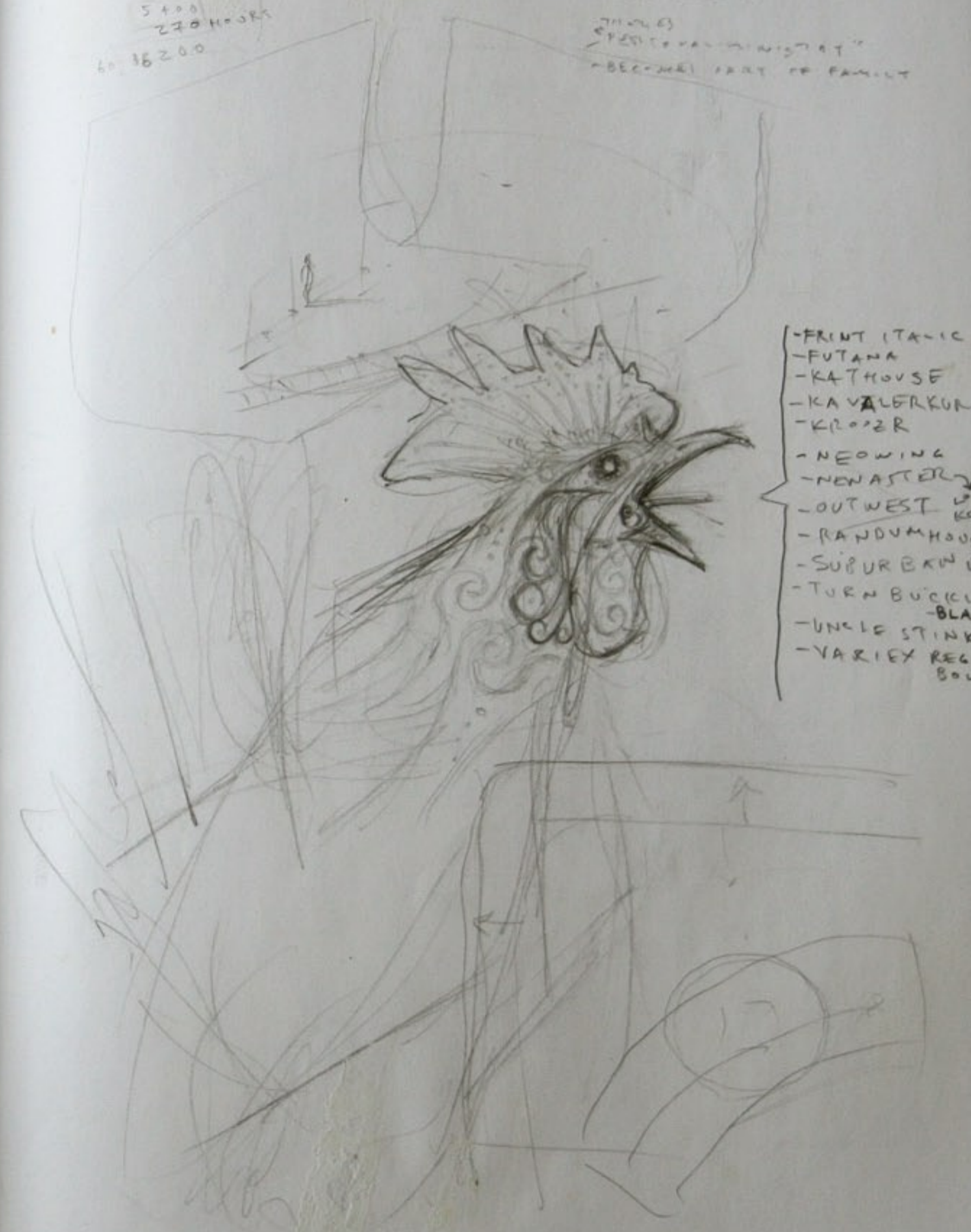

- FRONT ITALIC
- FUTANA
- KATHOUSE
- KA VALERKURSIVE
- KROOER
- NEOWING
- NEWASTERLY
- OUTWEST
- RANDOMHOUSE
- SUBURBAN BOLD
- TURNBUCKLE
- UNCLE STINKY
- VARIEX REG BOLD

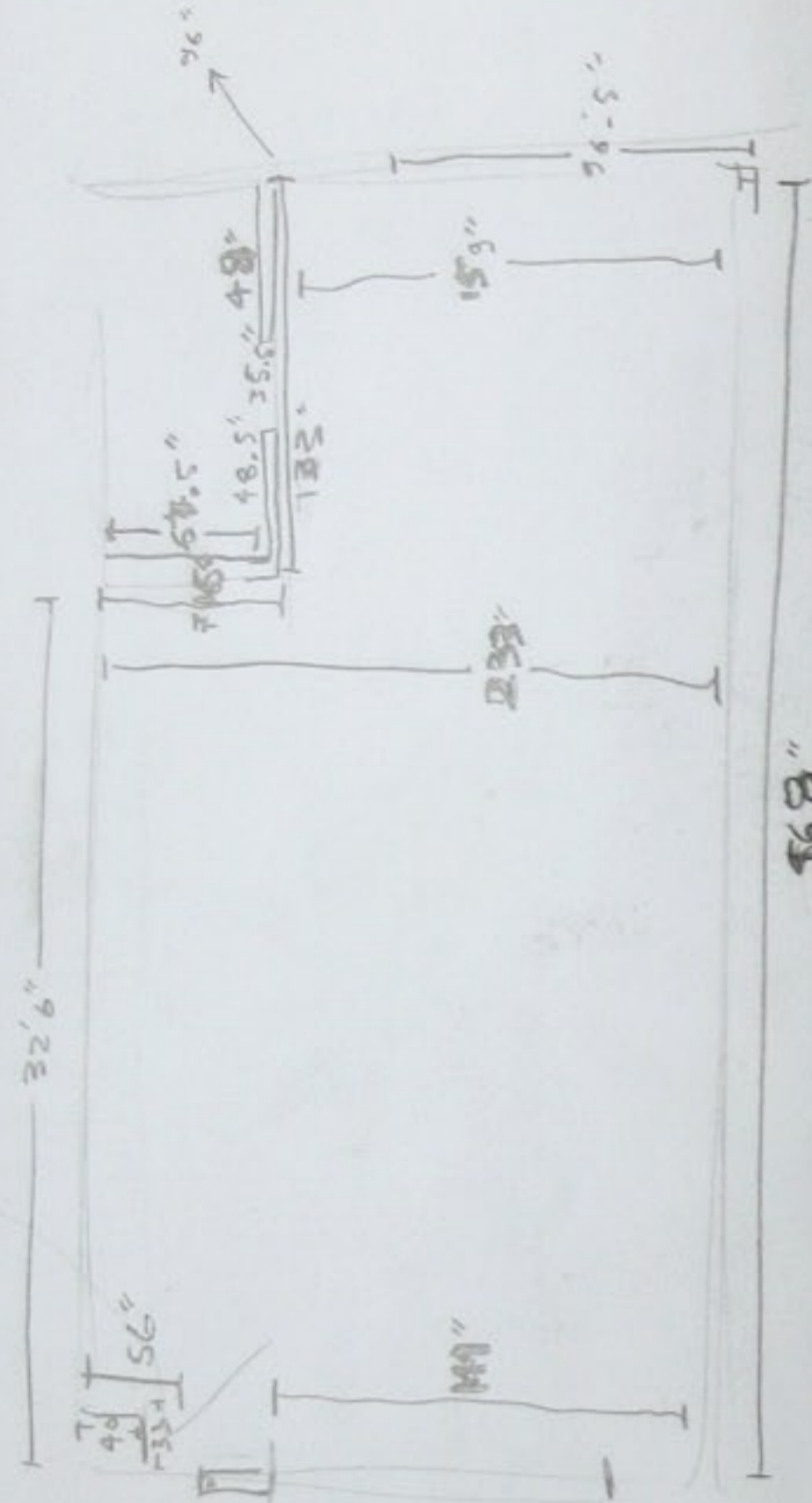

0.5188
60 3937

12'2" ↑

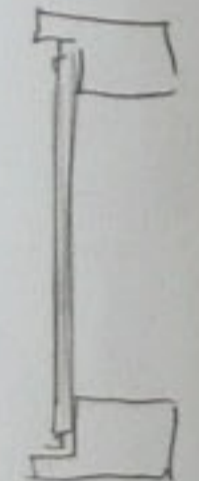

2.5
3.0
5.6

RETURN (3785 PAST)
-ITEMIZED ORD.
GARY ALLEN (214) 739 9088
(214) 739 9011
GEARY@GEARYALLEN.COM
15770 NORTH DALLAS PARKWAY
DALLAS, TX

RGB

75248

SUITE 1275

ZACHARY — BRINGER OF PESTILENCE

"DUNDERGROUND"
"SWISS FAMILY ROBINSON"
"WIND IN THE WILLOWS"

MAKE ME BIGGER!



CHARLES WEICHT
851 0178
CHARLES.WEICHT@TWCIVENT.COM

ASK ABOUT BOBBY
TUTORIAL
JBR-M-11

TENNESSEE HEALTH DEPT.

JUNE 2-7 FOR FINAL
1ST TEST TUES 31 TH → THURS 2ND SHOOT
SHOOT TUES 24 → EDIT APPROVED BY 26TH

\$50.00/MONTH



6K CAMERA
20 CHARS-SETS
22K & MONTHS

36 → 40K



- A MUSCLE
- A SMILE
- A LEECH
- A STETHOSCOPE
- A LACE
- TEWTER
- VRANIUM
- COLD TO MY EAR
- PROSTHETICS
- ABUSE
- MUSCLE
- PEPPERMINT
- DROOL
- SCHOOL
- OLD-FASHIONED
- BRAINS
- WORMS
- MUSHE M-LOE
- ANTS
- PECK
- BLOSSOM
- TENTS



"JACK SMACK SAYS:
THINK BEFORE YOU DO!"

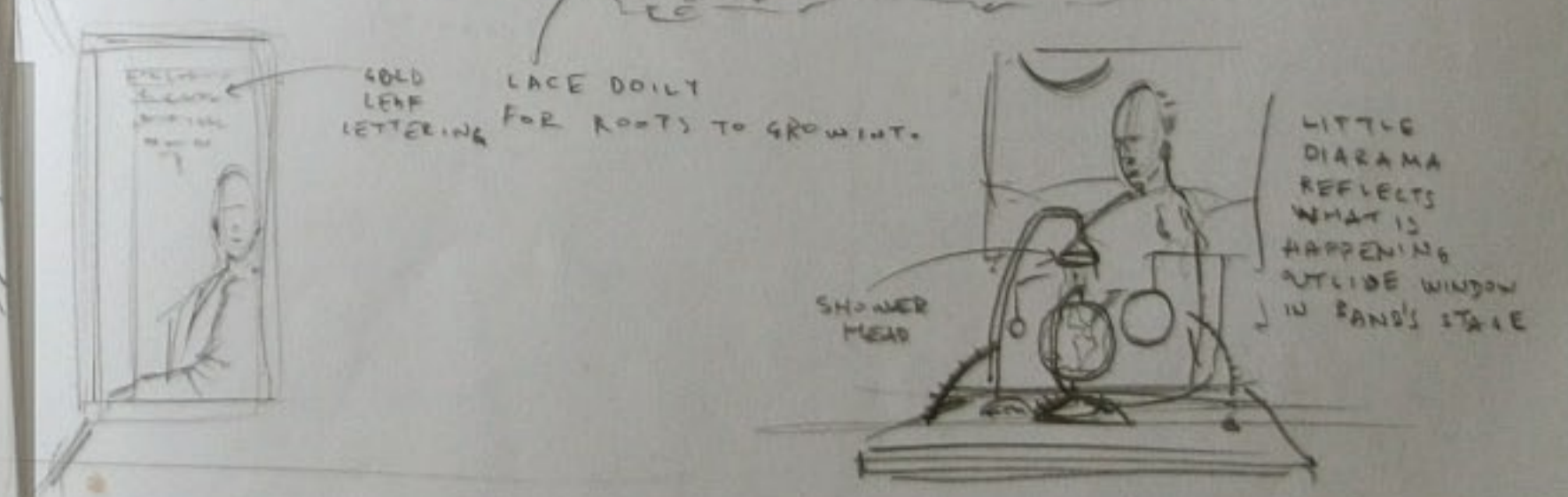
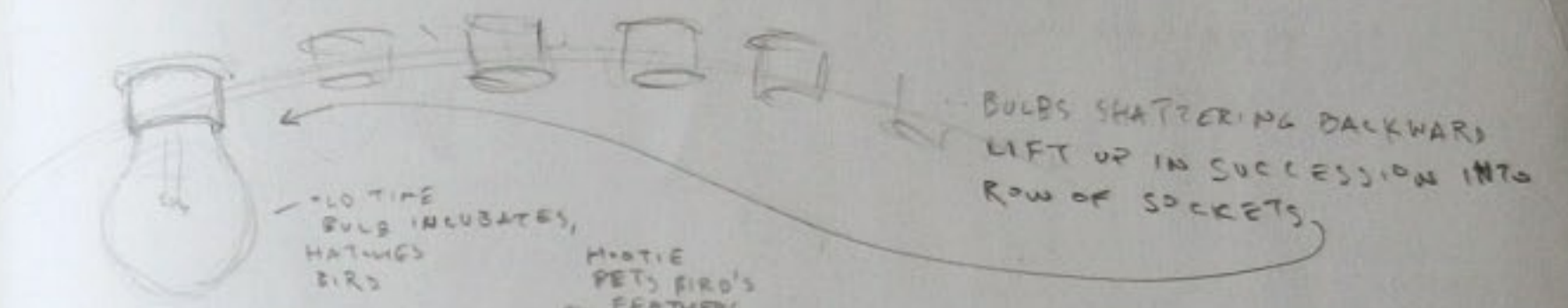
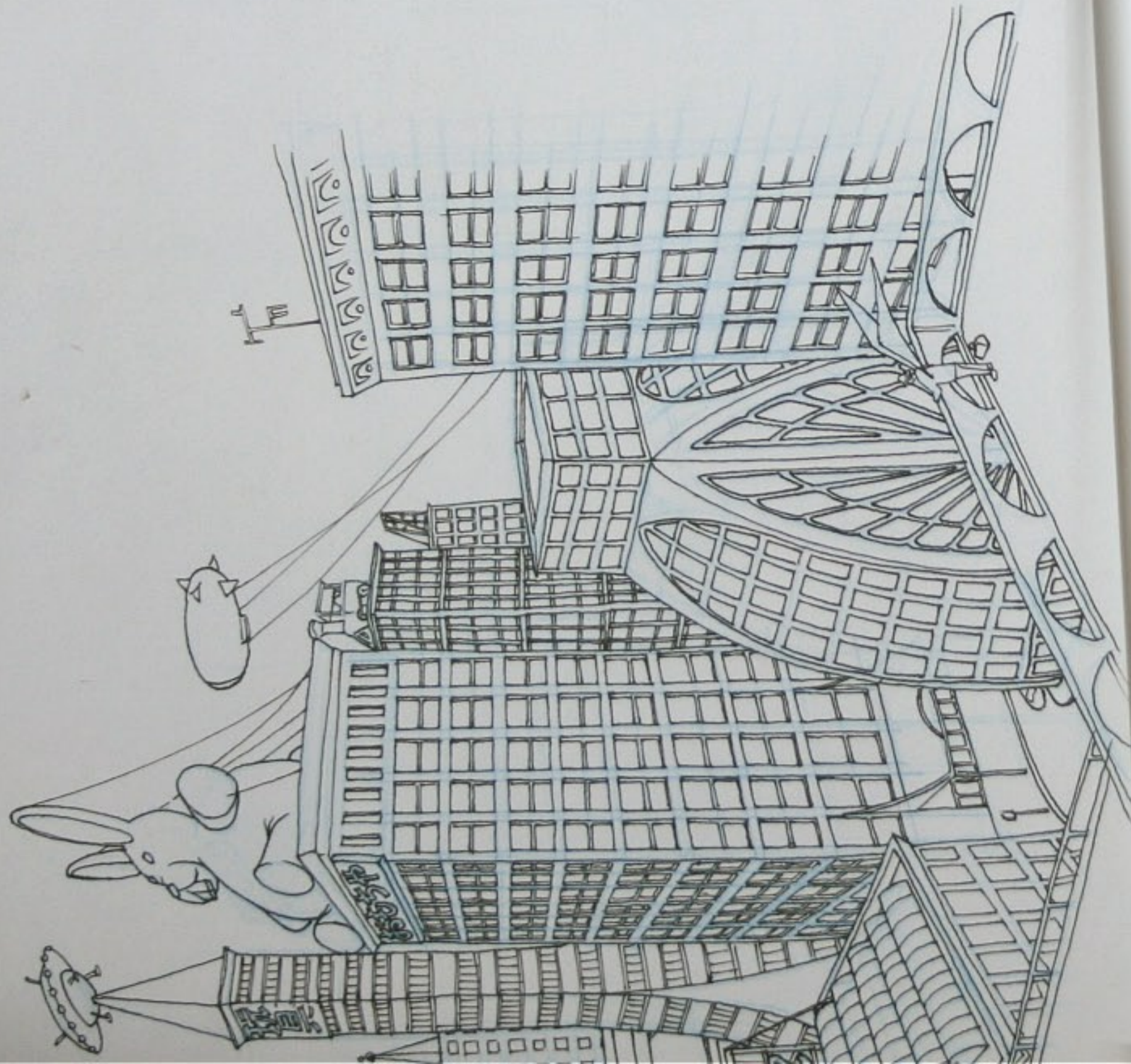

SALTED WATERCOLOUR WASH

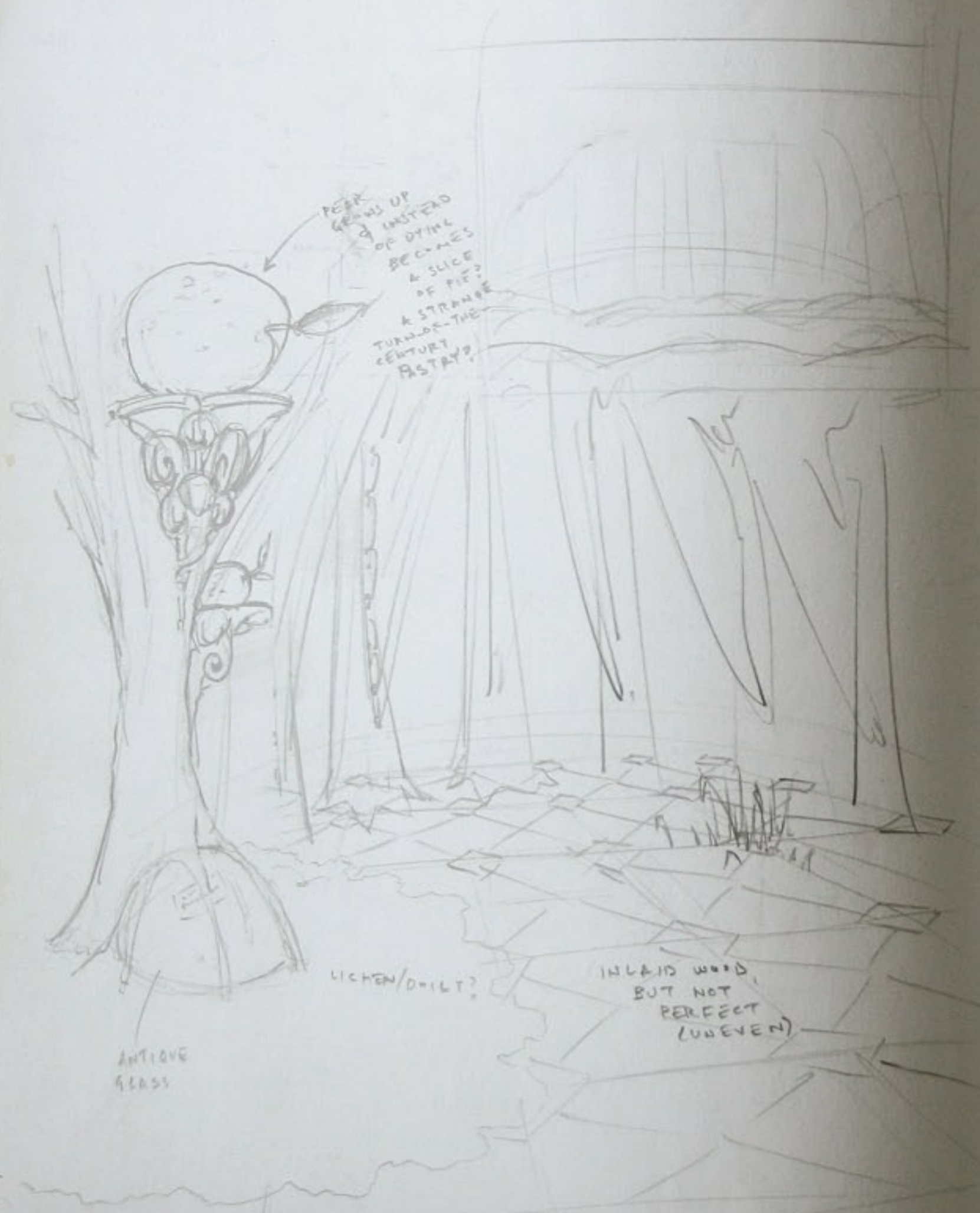

PEEK
GROWS UP
INSTEAD
OF DYING
BECOMES
A SLICE
OF PIE?
A STRANGE
TURN-OF-THE-
CENTURY
ASTAY?

LICHEN/DIRT?

INLAIN WOOD,
BUT NOT
PERFECT
(UNEVEN)

ANTIQUE
GLASS

PAN 5.
354 8789
+23 5230
TUES 9.30-10

RIGGING ALWAYS MOVING AS IF MECHANIZED

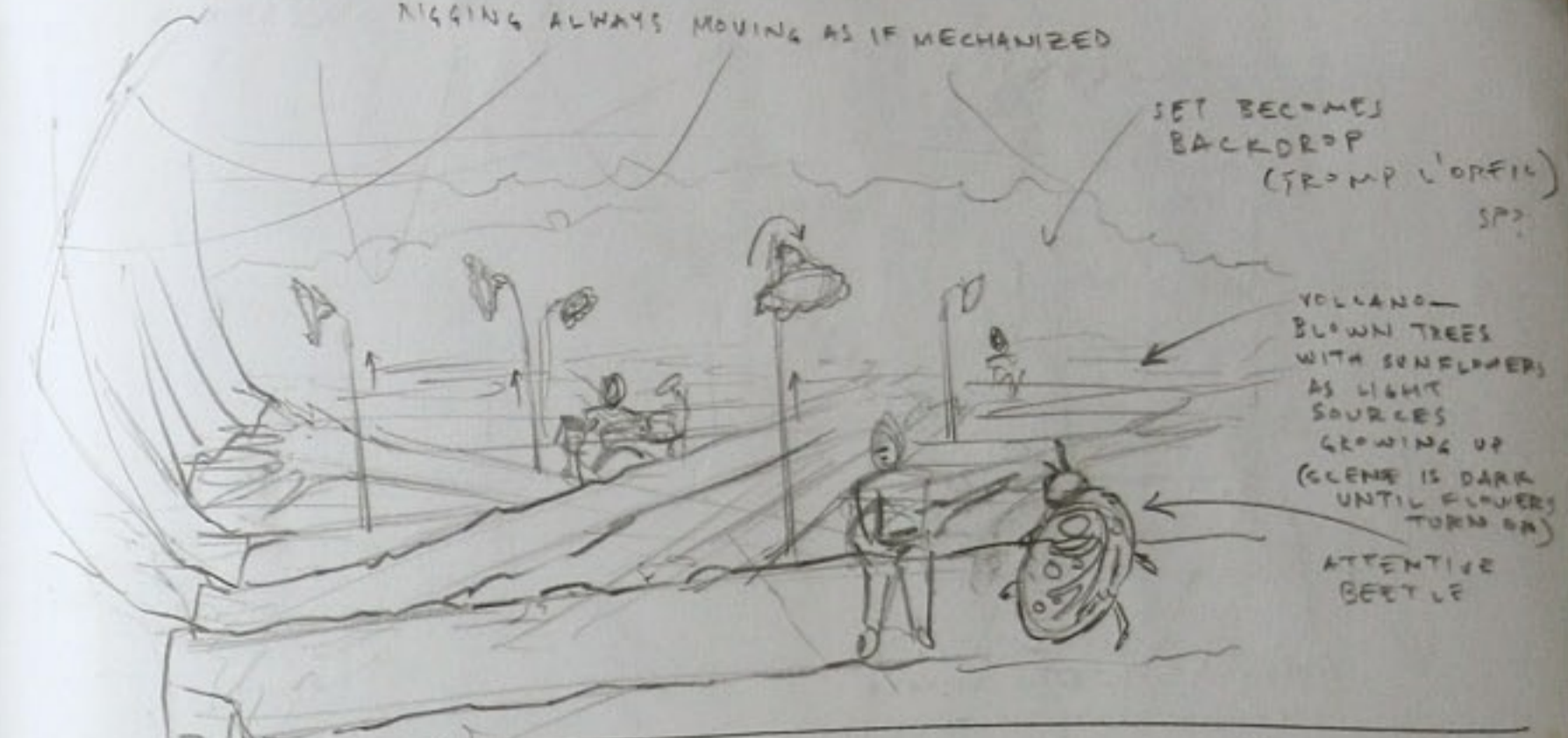

SET BECOMES
BACKDROP
(FROM L'OFFIC)
SP?

VOLCANO—
BLOWN TREES
WITH SUNFLOWERS
AS LIGHT
SOURCES
GROWING UP
(SCENE IS DARK
UNTIL FLOWERS
TURN ON)
ATTENTIVE
BEETLE

CLOUDS TRAVEL TOWARD BACKDROP, REACH
IT, & DROP
BEHIND HORIZON.

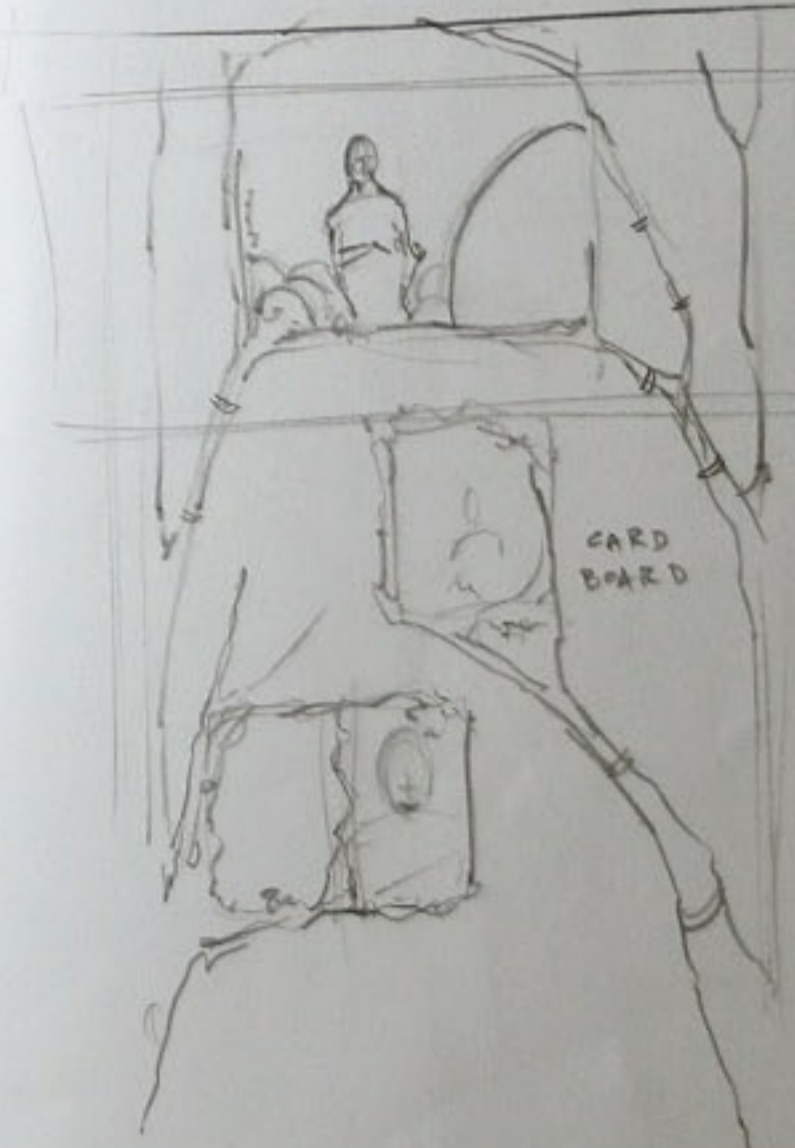
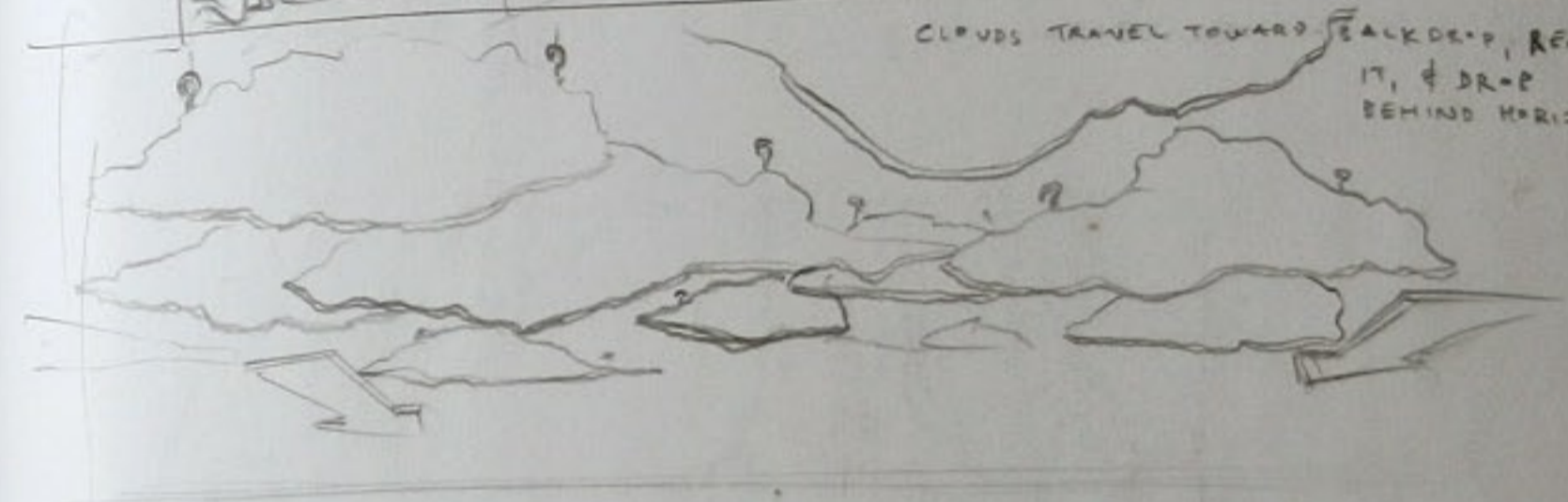

PAN UP &
AROUND
VIGNETTED
CARDBOARD
MAYBE
BEAD BOARD

CARD
BOARD

KIND
OF LIKE
CYPRESS ROOTS

- ① FRUIT FALLS NEXT TO HOOTIE
- ② FRUIT ROTS
- ③ GRASS & FLOWER VINES GROW
- ④ VINES GROW UP & ATTACH
EGGS IN THE DOME/COTE
BOXES IN BACKDROP, TURNING
THEM INTO FRUIT AS
THEY ATTACH TO & GROW
WITH THE VINES
(RESCUE)



(CERAMIC) TILE GAME VISIBLE THROUGH KNOT IN TREE BARK SOLVES ITSELF (IMAGE?)



FOLDED CARDBOARDS

JERRY SWINGING LIGHTS (STOP MOTION)

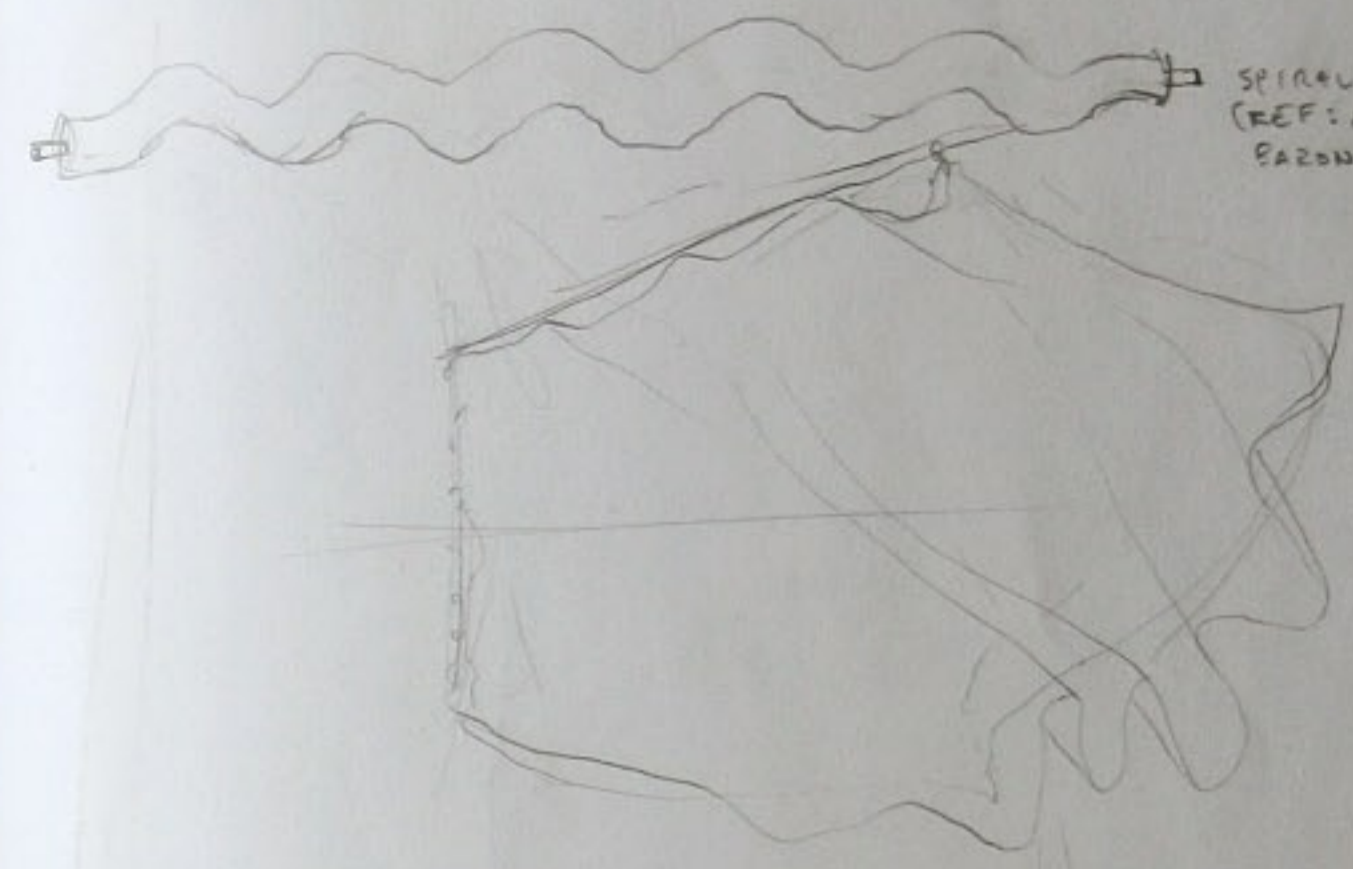
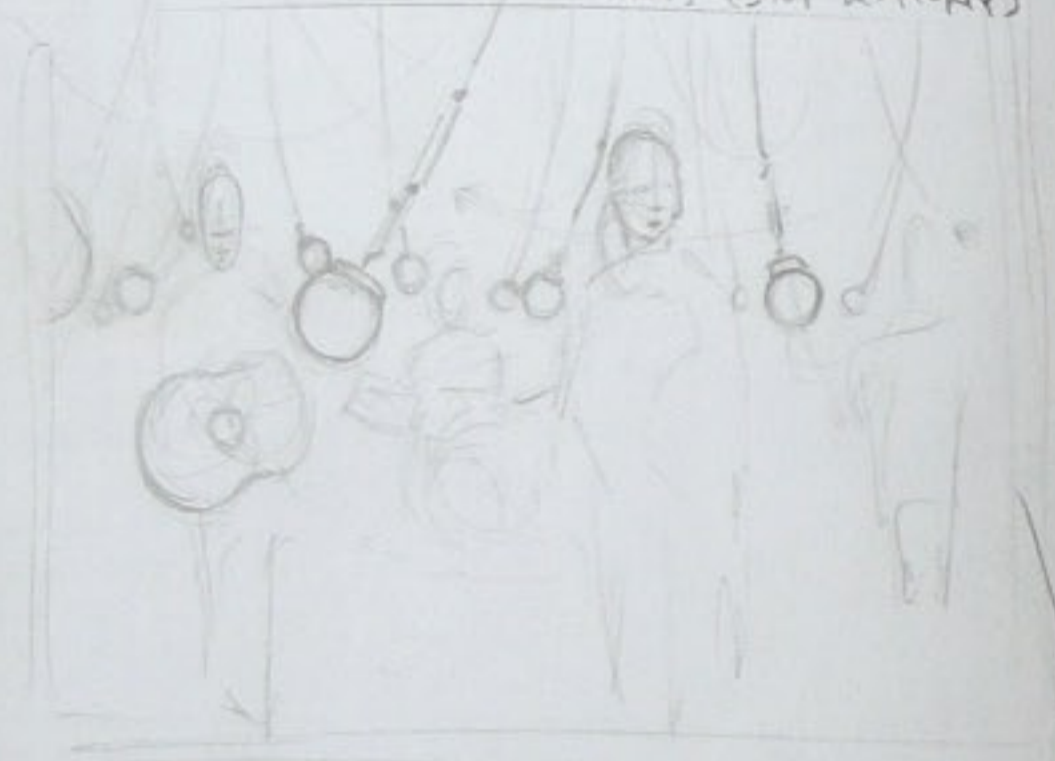

SPIRAL WAVES (REF: ADV. OF ERON MUNCHHAUSEN)



SLIDES OUT FROM UNDER THE FLOORBOARDS

THAT

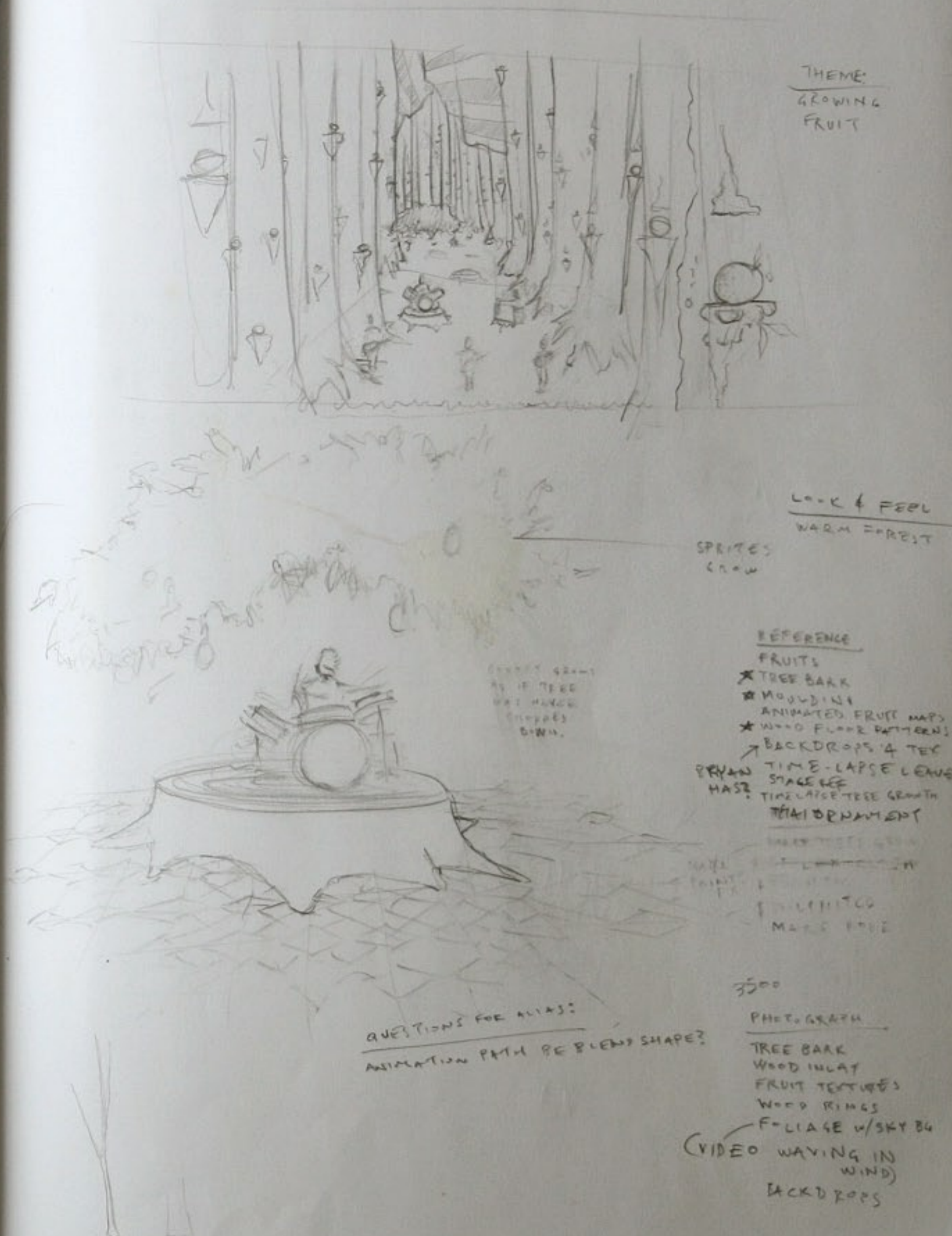
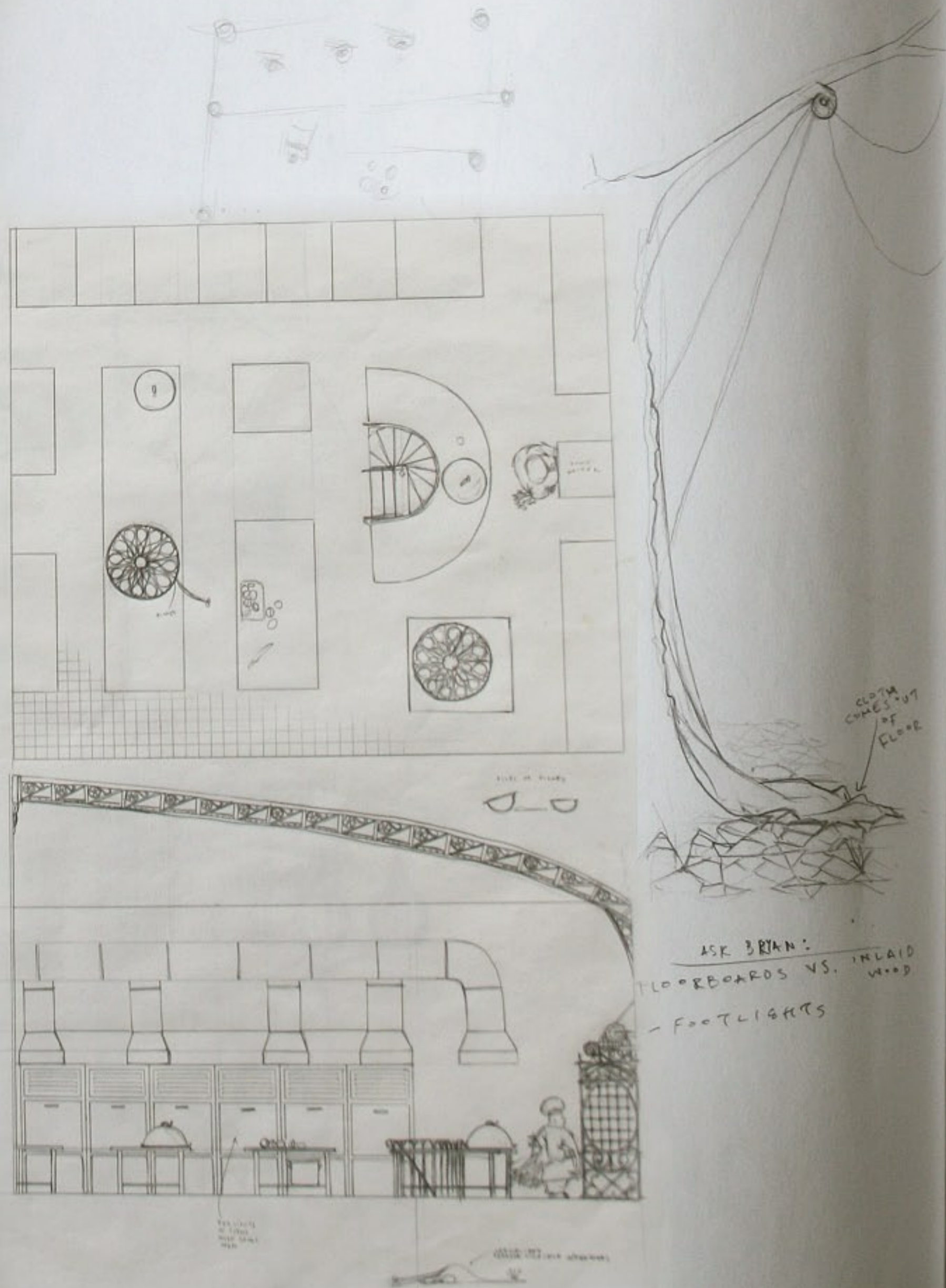

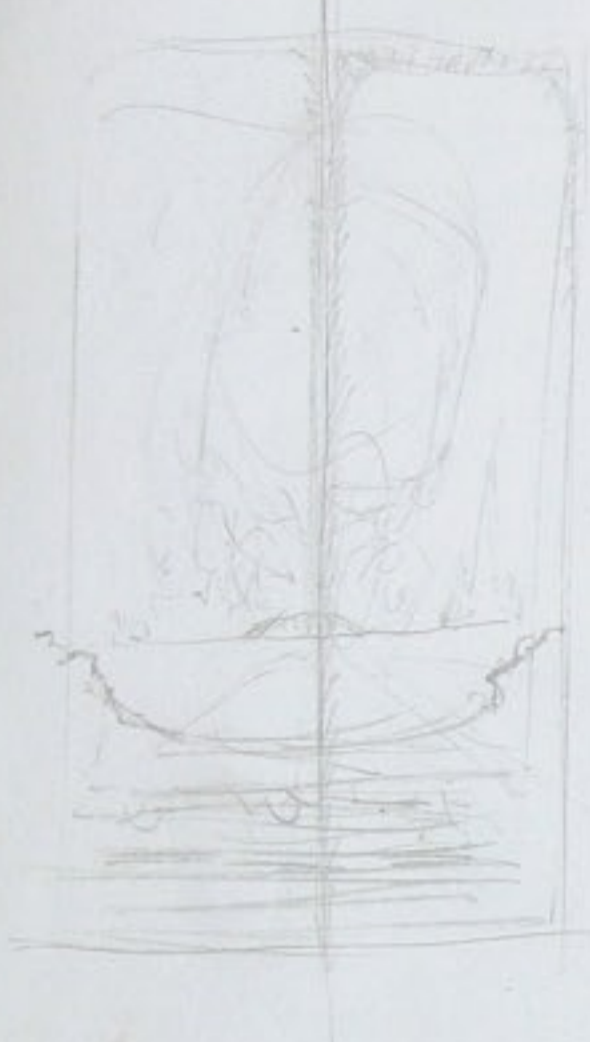

THE KID, SAME CITY,
DIFFERENT WORLDS.

- CHICK TRACTS
- CLIP COMMENTARY
- GUEST COMBINED WITH "CELEBRITY" COMMENTARY
- VARIOUS PEOPLE (WEATHERMAN) ON MOVIE'S ISSUES
- FOCUS ON EXAMPLES OF "SECOND CHANCES"

3K
2.5K
1.5K

KAT@FB-3.COM

- SHOW SCENE IDEAS

INTERACT
COMEST
COUNTER
NEW CLIPS
KAT W/ STAFF
MICHAEL

MOUNTED
TREES
3:16, 17

TRANSportes NAVIEROS ECUATORIANOS
R.U.C. 0968558770001
Matriz: 9 de Octubre N° 416 y Chile Edificio CITIBANK 8to. Piso
Telf.: 2567700 - 2567701 Fax: 2563567
Sucursal: Av. de las Américas s/n
E-mail: transnave@ecuadoronline.com
Guayaquil - Ecuador

CONTRIBUYENTE ESPECIAL
RESOLUCIÓN NO. 199
AUT S.R.L. N° 1103248435

NOTA DE VENTA 002-001- No. 0020317
Señor Carrizosa Fecha 28/07/00

R.U.C. _____ Tel: _____
Dirección: _____

| CANT. | DESCRIPCIÓN | V. UNIT. | V. TOTAL |
|-------|-------------|------------|----------|
| | Parqueo | | 0,40 |
| | | | |
| | | | |
| | | | |
| | | | |
| | | | |
| | | | |
| | | TOTAL US\$ | 0,40 |

CLIENTE

JAKE
44:31A

JEREMIAH
44:0A,

MICHAEL
19:33
26:6 *
34:16A
38:35
43:20 *

BLUR
BOOKFACE TITILLI
BULMER
BO DOWI
CASAVE
THE TANTANAM BOAT CONVO
GOUDY

TRAILER
SHOT @
BEGINNI

"THE KID" THIS IN THE PICTURE
CONCEALMENT
GREATEST FINISHER
DOMINATORS
RIVALRIES

CHECK TRACT PRICE

10 BACKGROUNDS

RUSSELL CRAWFORD
7147025

GPARRERA@
U4HDD.COM
WREY@
GREYSCALE.COM



ROBERT ANDERSON 46 3231
7916 MEADOWVIEW DRIVE 4886131

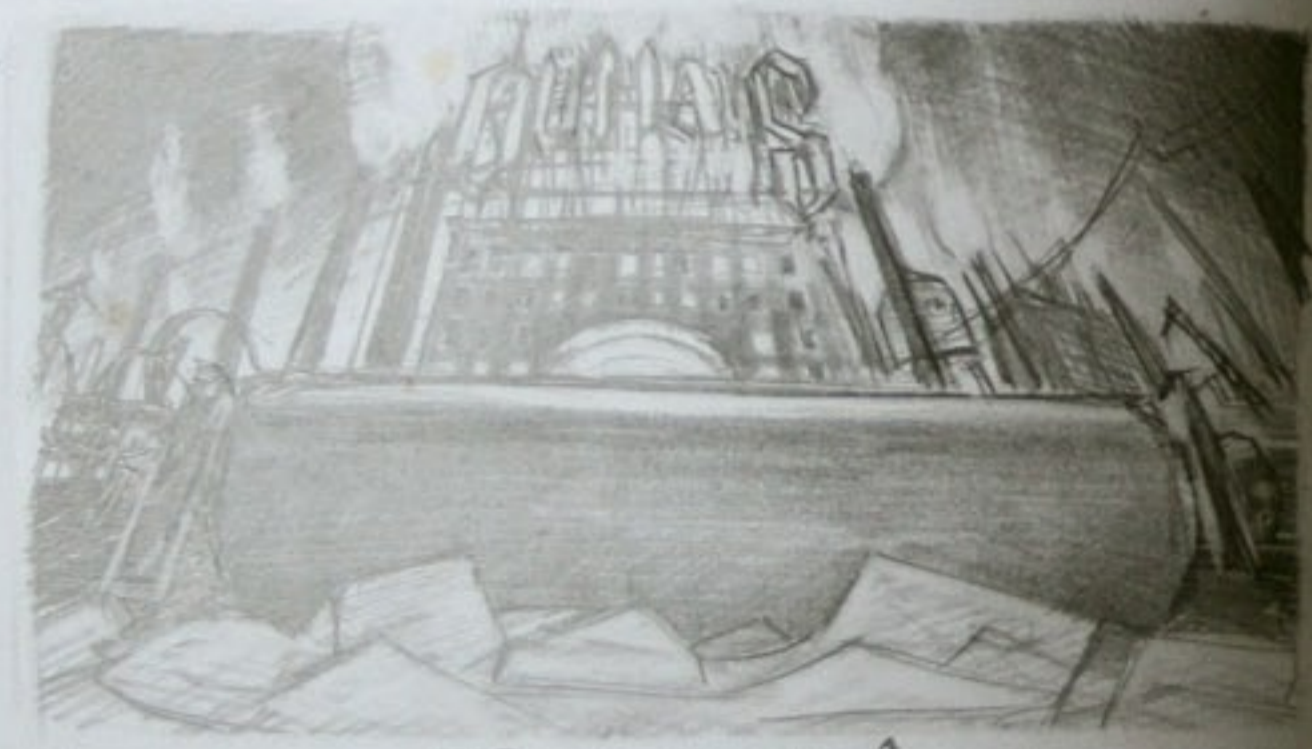

OUT OF FOCUS? ↗

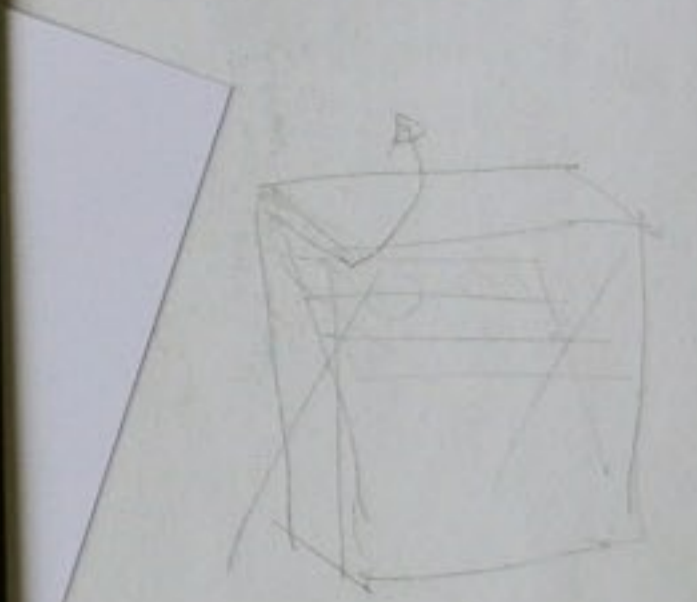
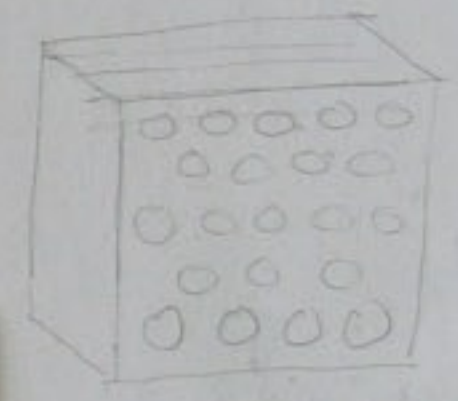
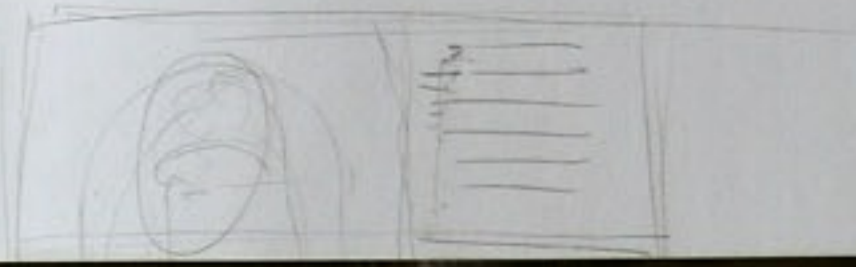

99
pic

CM

THE LEFT,
MELLE HUGGARD
AND MORE



12

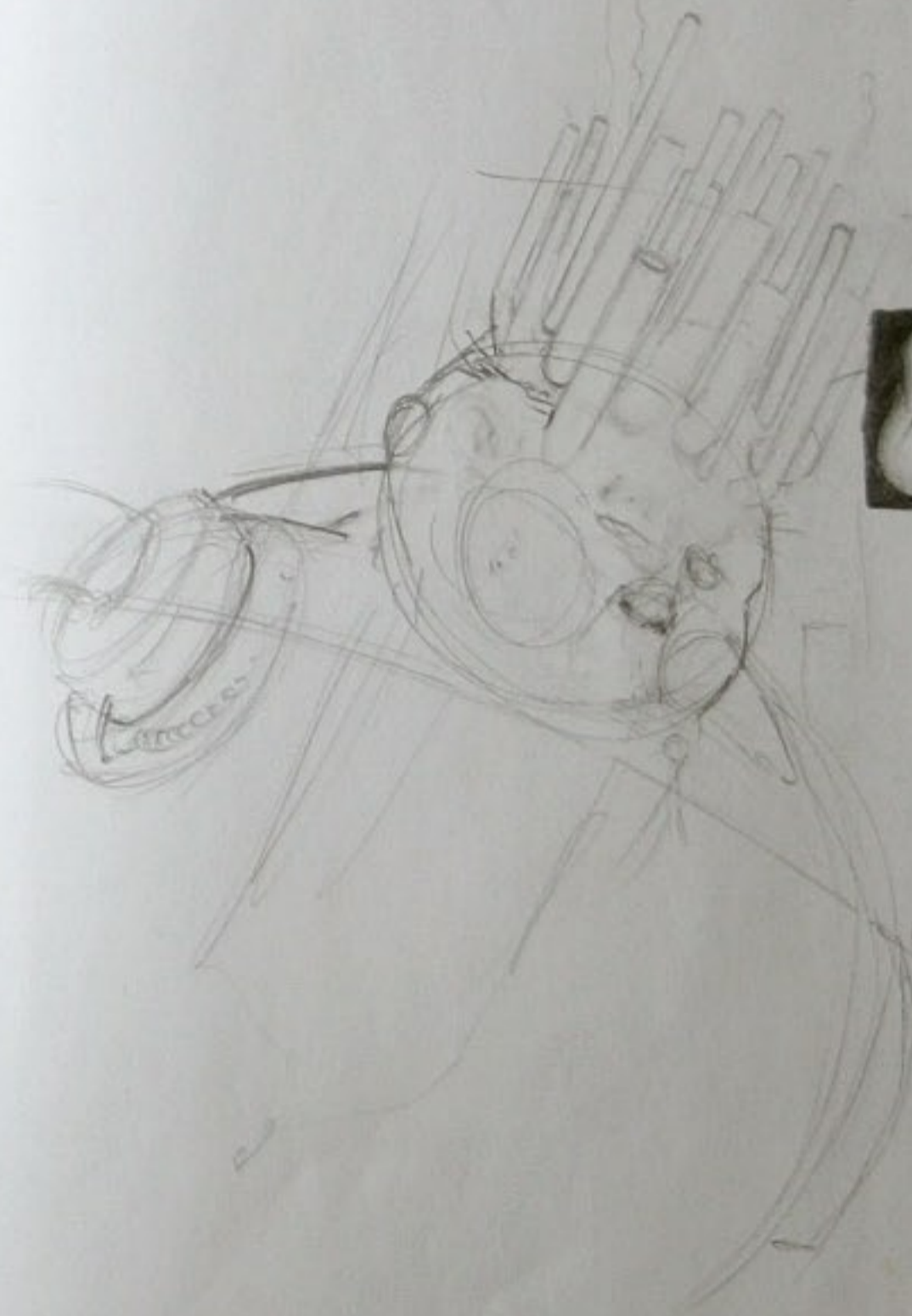

TREATMENT

CHARLES
251
2048

10-KUP
EDUCATIONAL
INSTRUMENTS
ELECTRIC CRAB

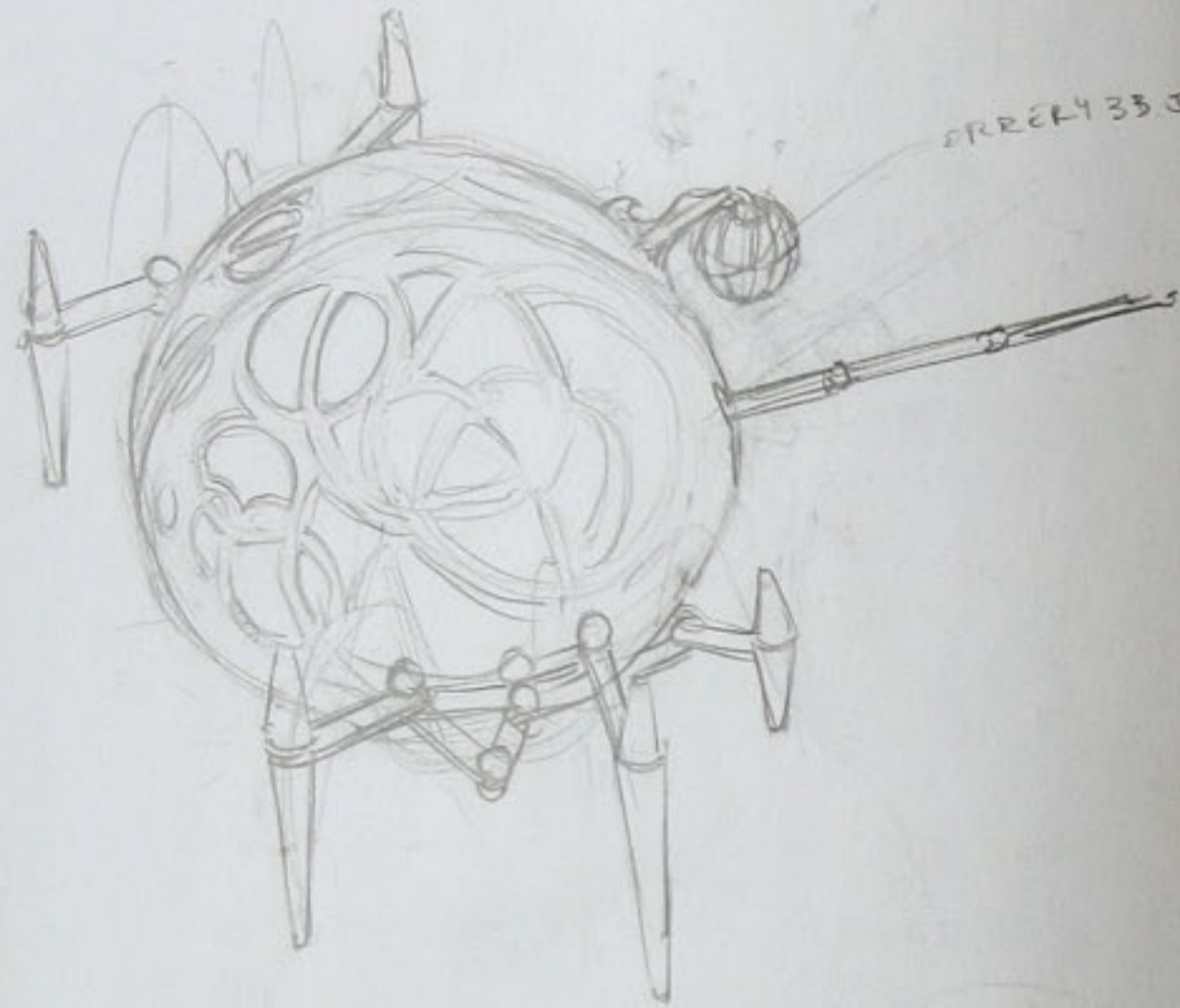

FRREY 33 SPA

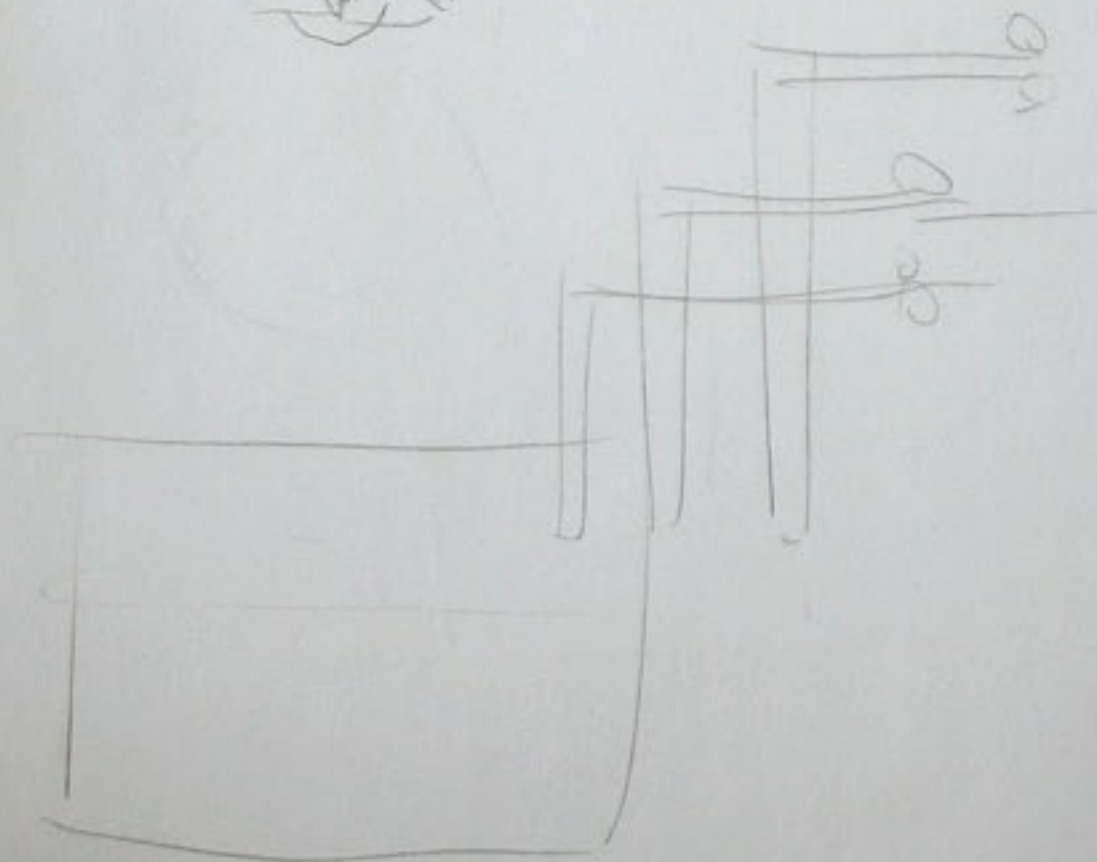

STAT

BABY CREESE
SEWING MACHINE

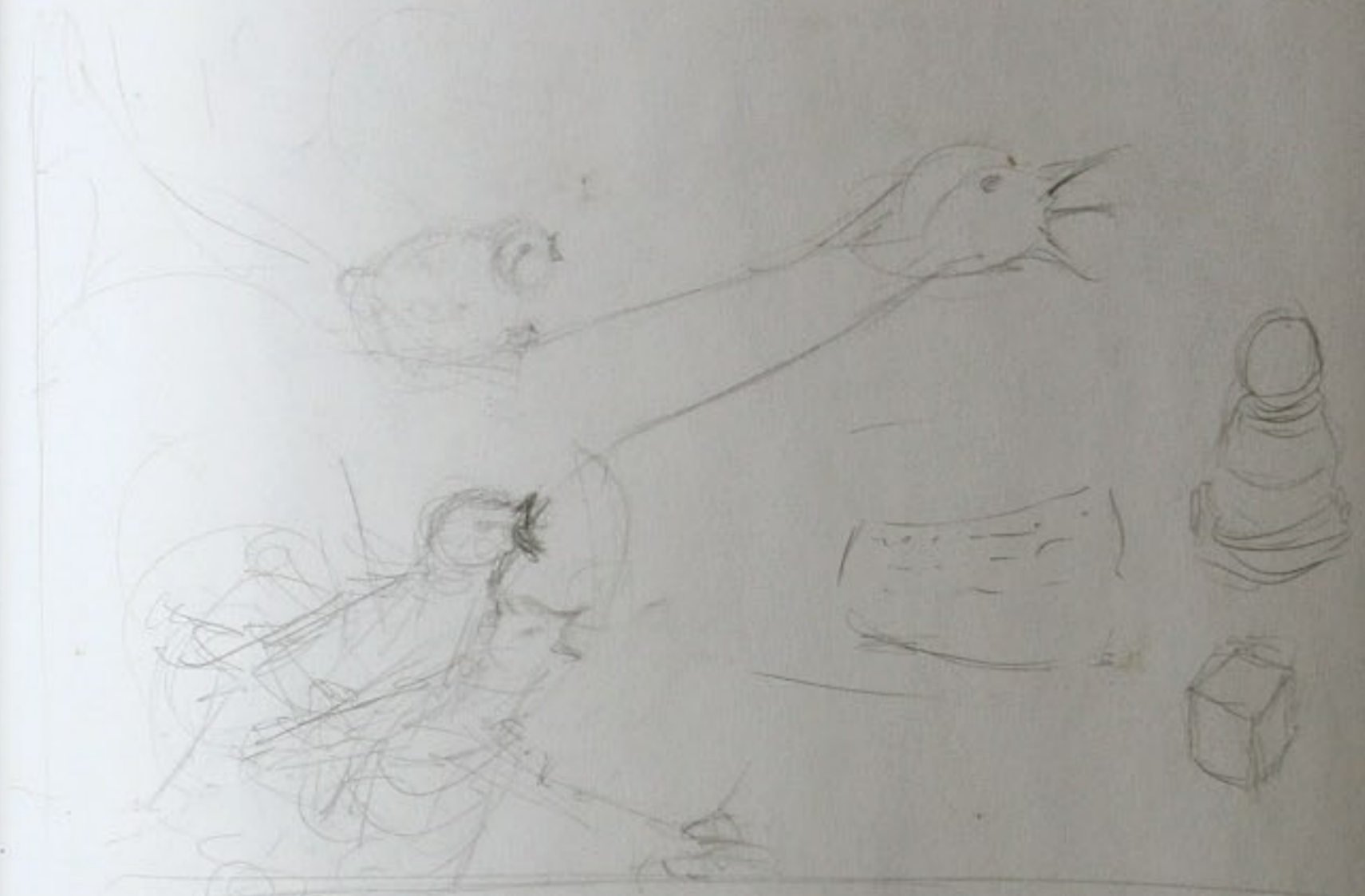

ISAIAH 50:4
EPL 5:13,14

LEGEND BOARD
SKETCHES

- INTER-GET-TO
TRANSLATION
- PERMANENT
DRAWING
- CONSTRUCTION

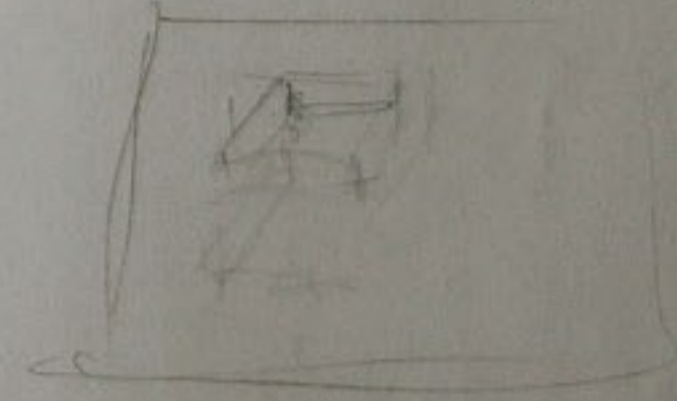



HERB WALTER'S MAPLE ALE





HIP HOP
COUNTRY
ROCK - TAT...
TENTED GRASS



D of F

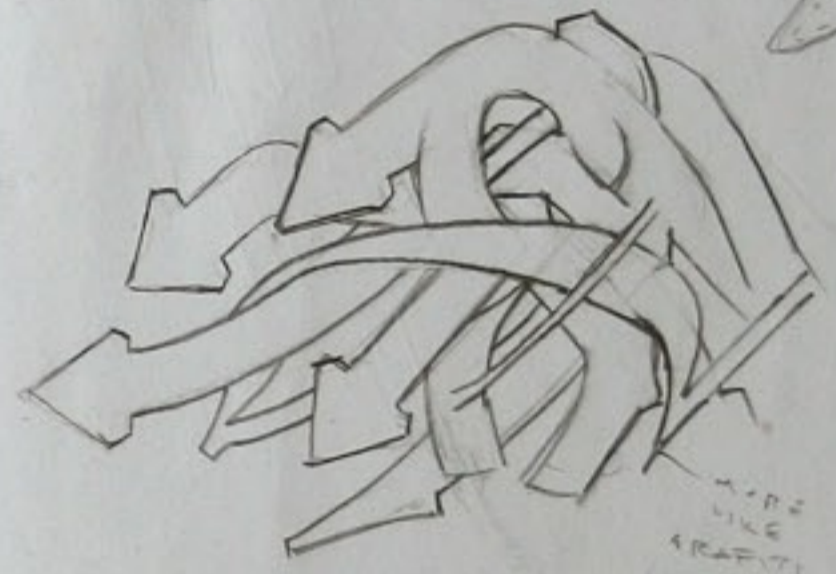

WIRE
MUSIC
GRAFFITI

TRIBAL TATTOO

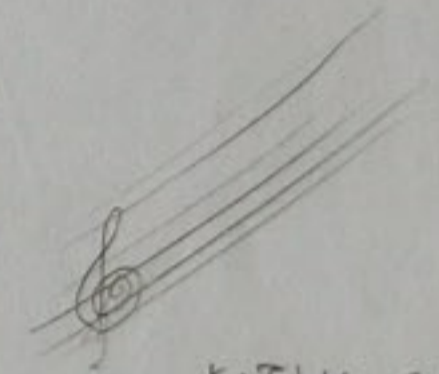

KATLIN CARVER

POBOW KELLY
CLARKSON

CANTON JONES

NATALIE GRANT

AMY GRANT

GEORGE HUFF

BIE VOCAL CRY

BADLAW GIRL

N-CU

AUDIO ADRENALINE

MMS

DELLA REESE
CLASSICAL
BEAUTIFAL

TBONE



WILD VISION 5
LIFEWORK 2.5
SEN

JEFF HAND → AMSTERDAM (HOLMA)
BARMER → CASH COW → UPLAND



1/2
\$22500

SAT, DEC 16 @ 1:00



- 1000 A/T
- REPHRASE MOVIE
- SOUNDTRACK
- VO
- MATTE SHOTING
- CAMERA?
- LITTLE PROJECTS

JEANERA PRODUCTIONS @
GMAIC. CAS

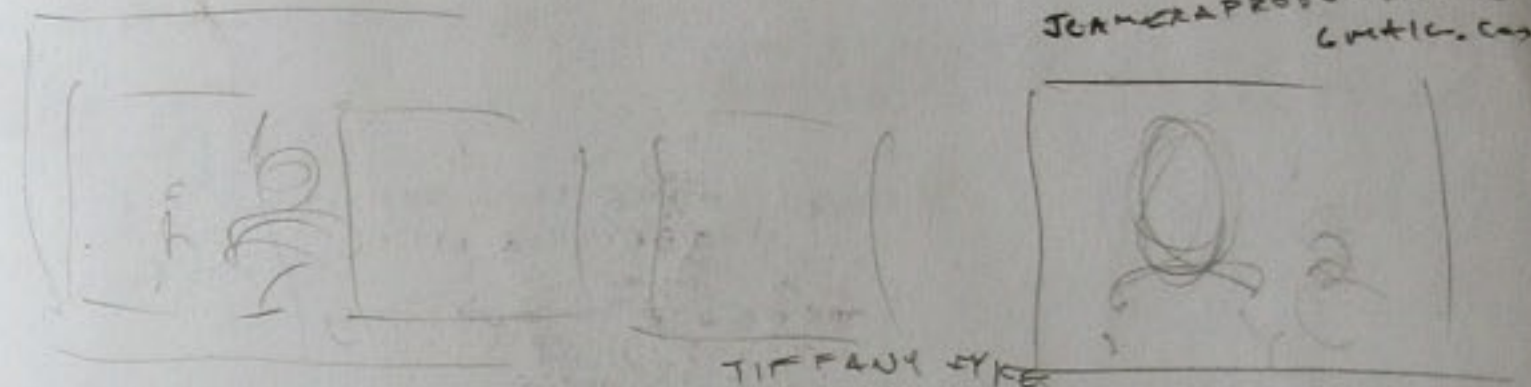

TIFFANY TYRES
277 5413

MONTAGE 3



- STICKS AS PROP DELIVERY
- BOXES FOR KIDS TO RIDE ON
- TRAMPOLINE
- ROPE (NOT GREEN)
- LARGE, TALL BOX (WEIGHT)
- GREEN SHEET FOR KIDS TO PULL

- 1 ~~CONTAINER PRISON~~ (GREEN) - COMING OUT FROM UNDER BOARD
- 2 AIRSTAIR - RUNNING & JUMPING OVER LETTERS
- 3

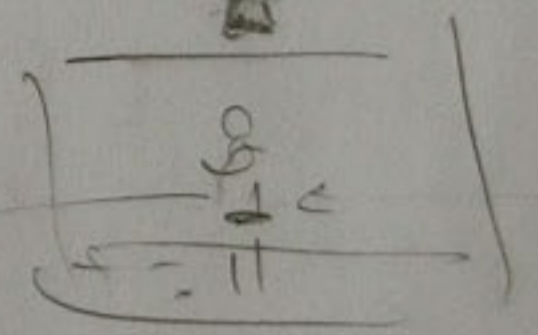

- 53
- 577
- 577W
- 06LC
- TPW
- HAN
- DRALUC
- WUYAN
- 0CT

NEW SHIRT FOR ALLEN REPEITION TO BE SHAW

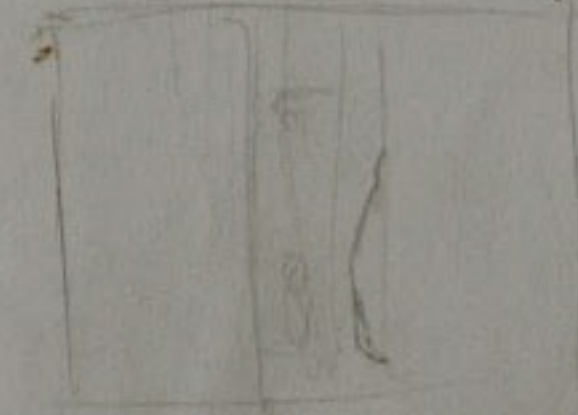

TOSI =
CITY - F 900

ASSP - CAMERA

ABRIENNE OUTLAW
479 8623

7TH

14TH - CHARACTERS

21ST - SET & PROPS

28TH - SCENE CONSTRUCTION & LIGHTING

4TH - SHOOTING

11TH - SHOOTING

18TH - COMPOSITING & SOUND

HA - HA



- STAR CASE
- HEAD & COVERS
- CUPBOARD W/STRAP
- BOOTS & HAT
- GIRL'S ROOM & VA & WALL PAPER

- SET
- LAMPPOSTS
 - WINDMILLS
 - BUSHES
 - GRATES
 - PIPES
 - STATUES
 - BUILDING
 - ANTENNAE

768 X 1844

SHOOT:

- DUST HIT WHEN DUG THROUGH OUT
- DUST FOR BIKE
-

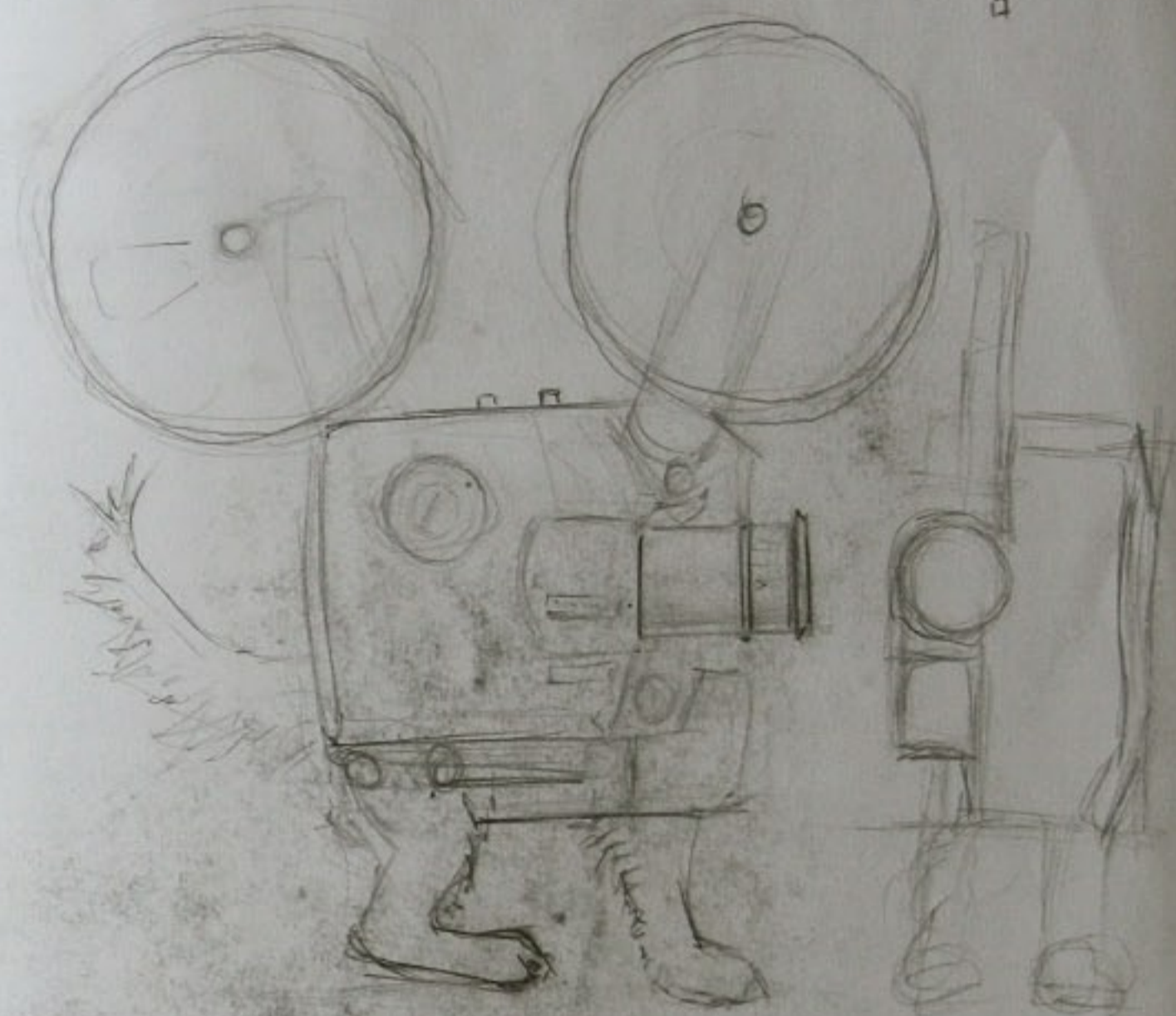

- HARD WOOD STAKE
- TUBE FOR LENSES

- FOAM
- LEATHER PAPER @ PLAZA FOR GUITAR CASE

cdin
ANIMATED
JAVANCO
DASHVILLE FISH MARKET
FARMER'S MARKET FLEA MARKET



SECOND LIFE

- 5 THEMED
- ① GENTLE
- ② AUTONOME
- ③ BIG EAST
- ④ MORE TODAY BETTER TOMORROW
- ⑤ VITREUM



ANIMATION

ILLUSTRATION

SKETCHBOOK

JONATHAN RICHTER
JONATHAN RICHTER

NEW MONTAGE?

MOSAIC (FINISH)
FILMFEST
LTM?
EDDAC?
MILLION PIECES
ON THE ROAD
LOTTERY
SKETCHBOOK - LOOK
THROUGH
DRIVES

WHERE IS PART?
30 APRIL 21



155-63
□ Why god's my brother's name?
□ How can I watch TV & get smarter?
□

500
JULIAN
SMITH
PRODUCTIONS
11 7th

EMERGENCY
254 6181

MANTANISME
PAVID
214 1232

0 1st
0 2nd
0 3rd
0 4th
0 5th
0 6th
0 7th
0 8th
0 9th
0 10th
0 11th
0 12th

11 7th
11 7th
11 7th
11 7th
11 7th
11 7th
11 7th
11 7th
11 7th
11 7th
11 7th
11 7th



□ Simple puppets with assembly
□ simple, simple details
□ no book-stone details

642 5138
Rusher
70888
95.00
19.00
Total 8:30-12



WINE THE GODS!

CHILDREN KEY



ROCKETSCIENCEDESIGN.COM/CLIENTS/COOK/

HENRY DARGER
"REALMS OF THE
UNREAL"

KELLS BLACK
EXPERIMENT

BLACK RIDER
FILM?

YOUTUBE: TOM WAITS
ANIMATION

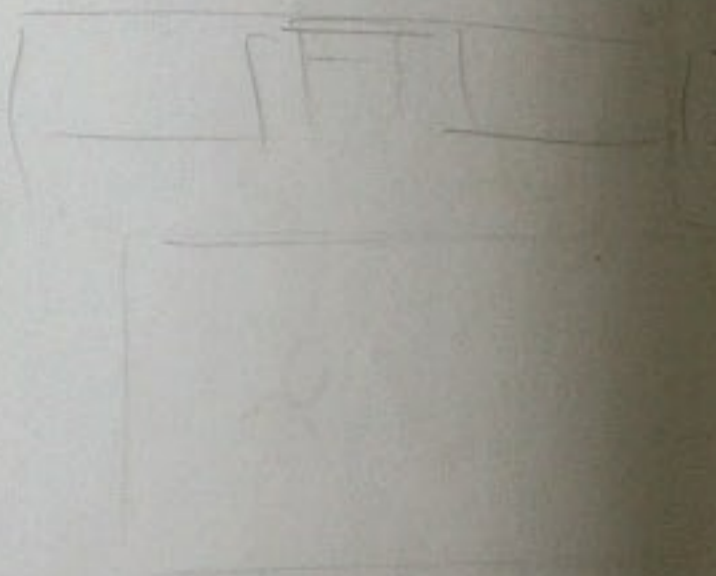

DVD PLANO ONE
SESSION B OVERLAY

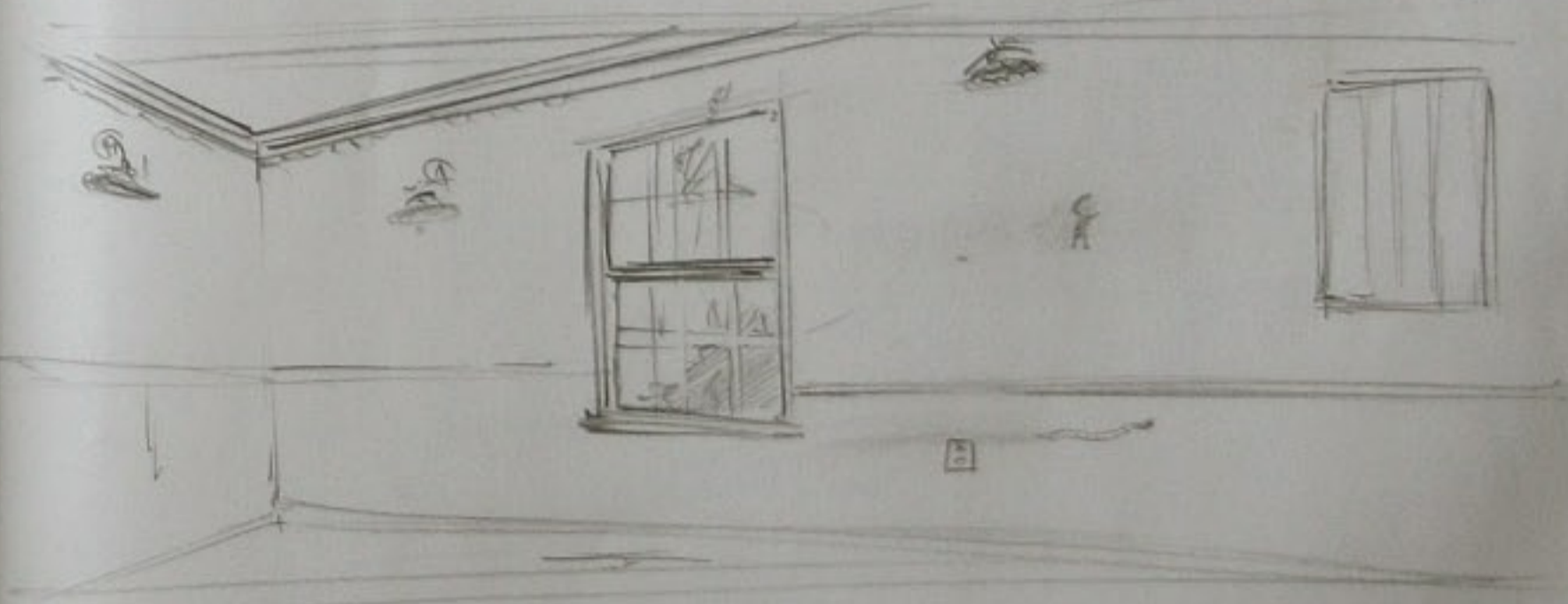
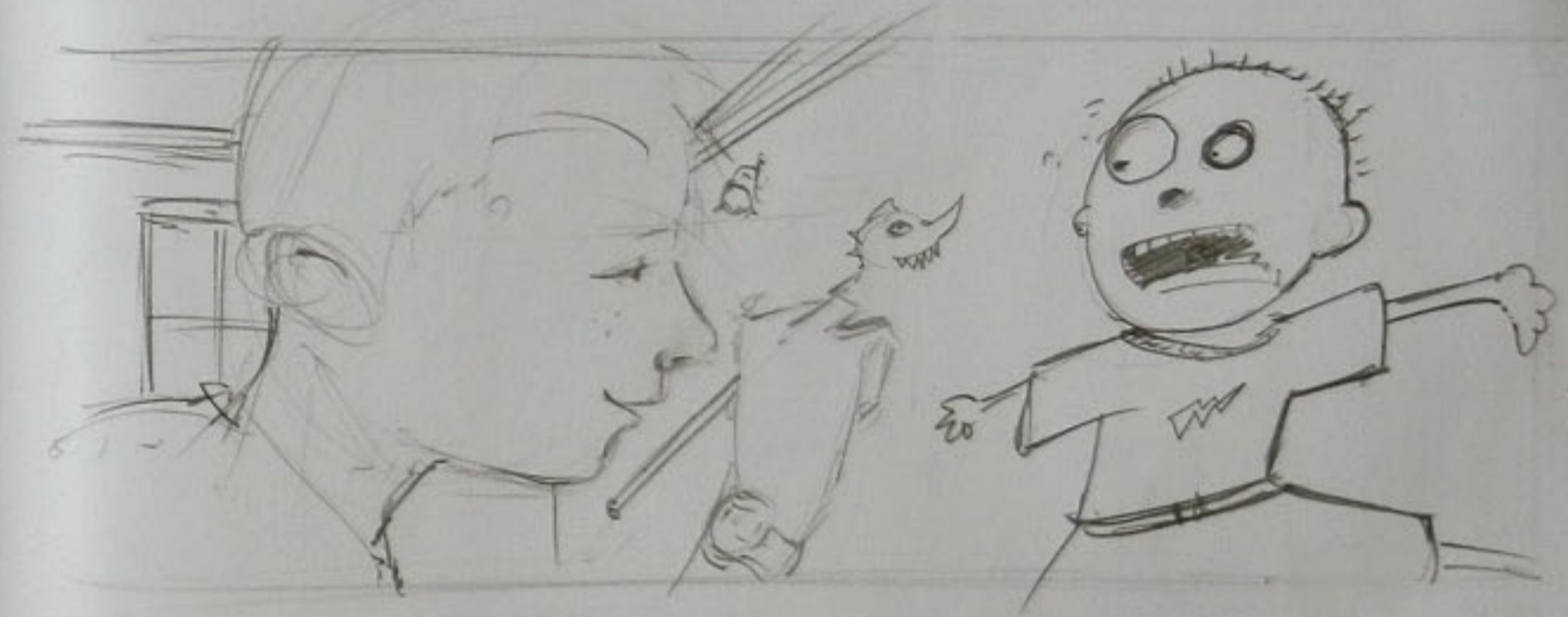

UVCL8 PRO
INSTANT LID

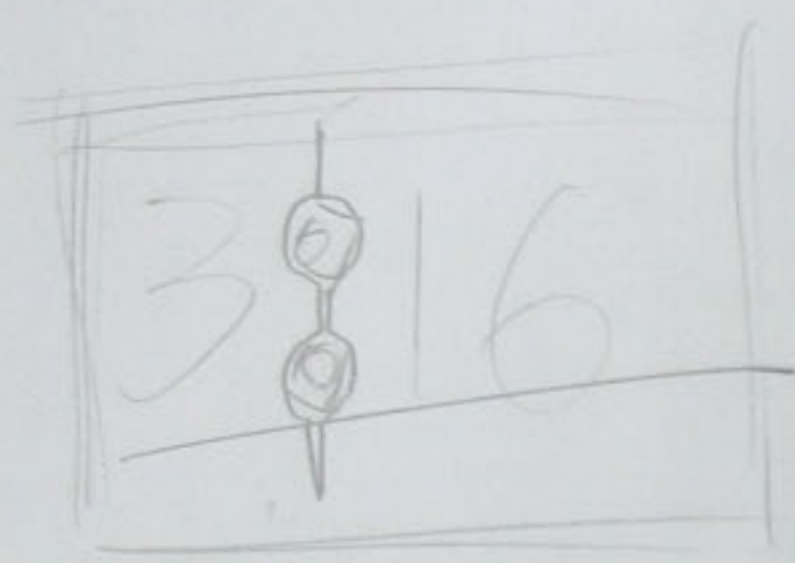

SECTION ① INTRO
HOPE
911 - BROLL TIME LAPSE OF BLOSS
(44.57)
SAYS 3/16 → CUT IN ON

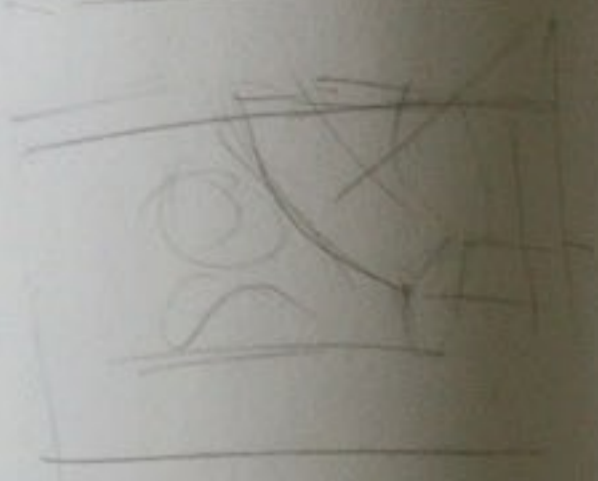

SUGAR COLORED MOUNTAIN
TERRA LITTA WARRIORS
THE BAKKAT CHILDREN

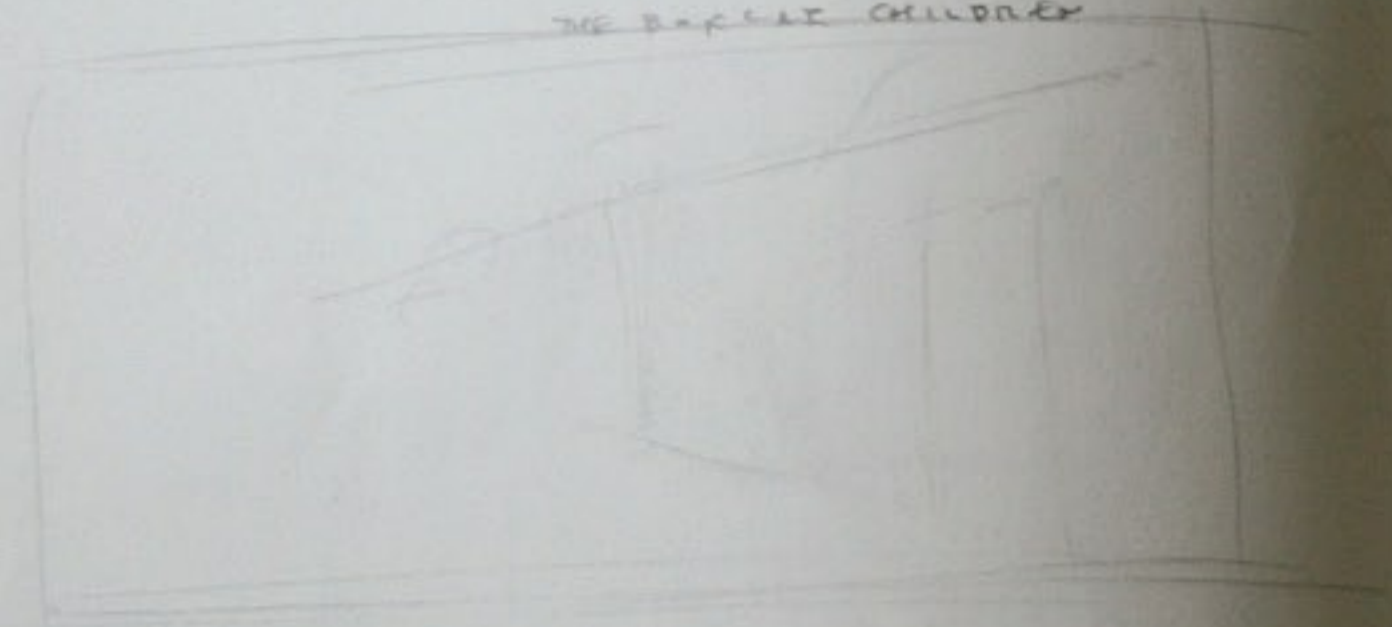

BELLY
CELLING



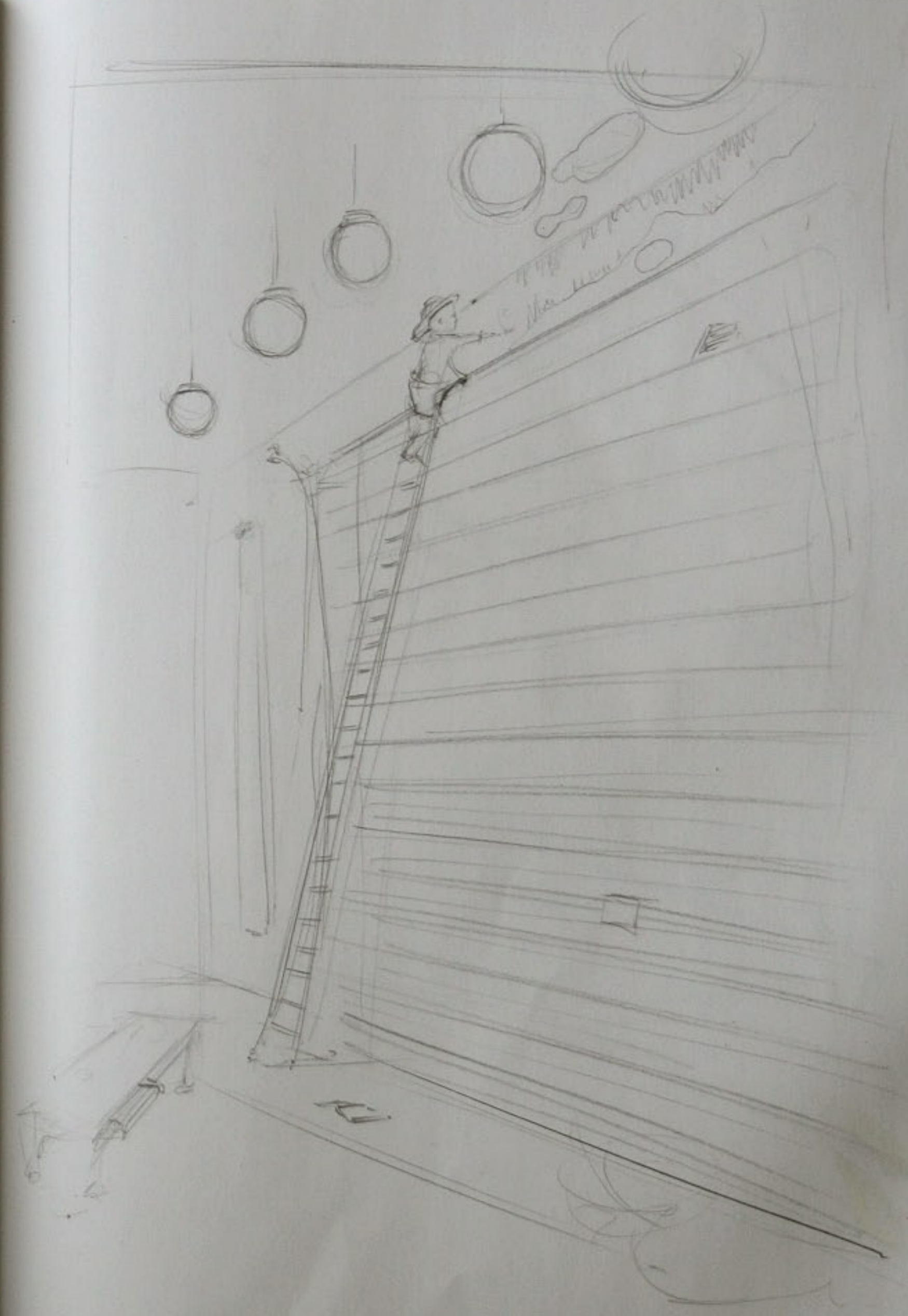
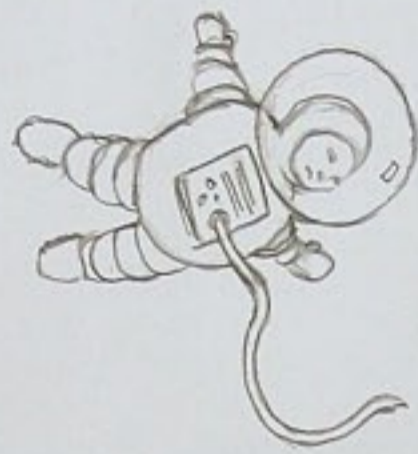
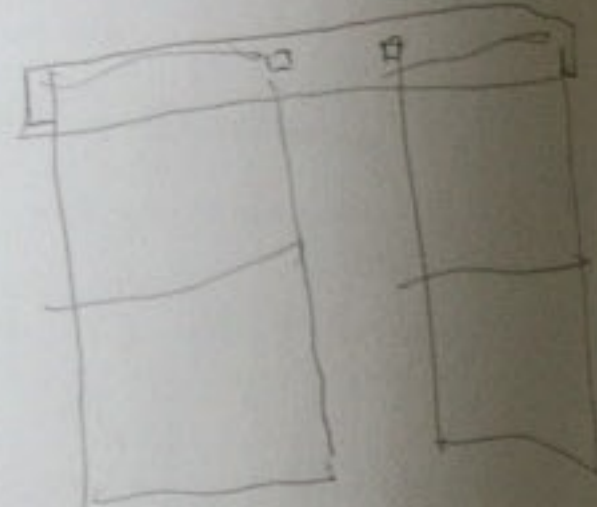

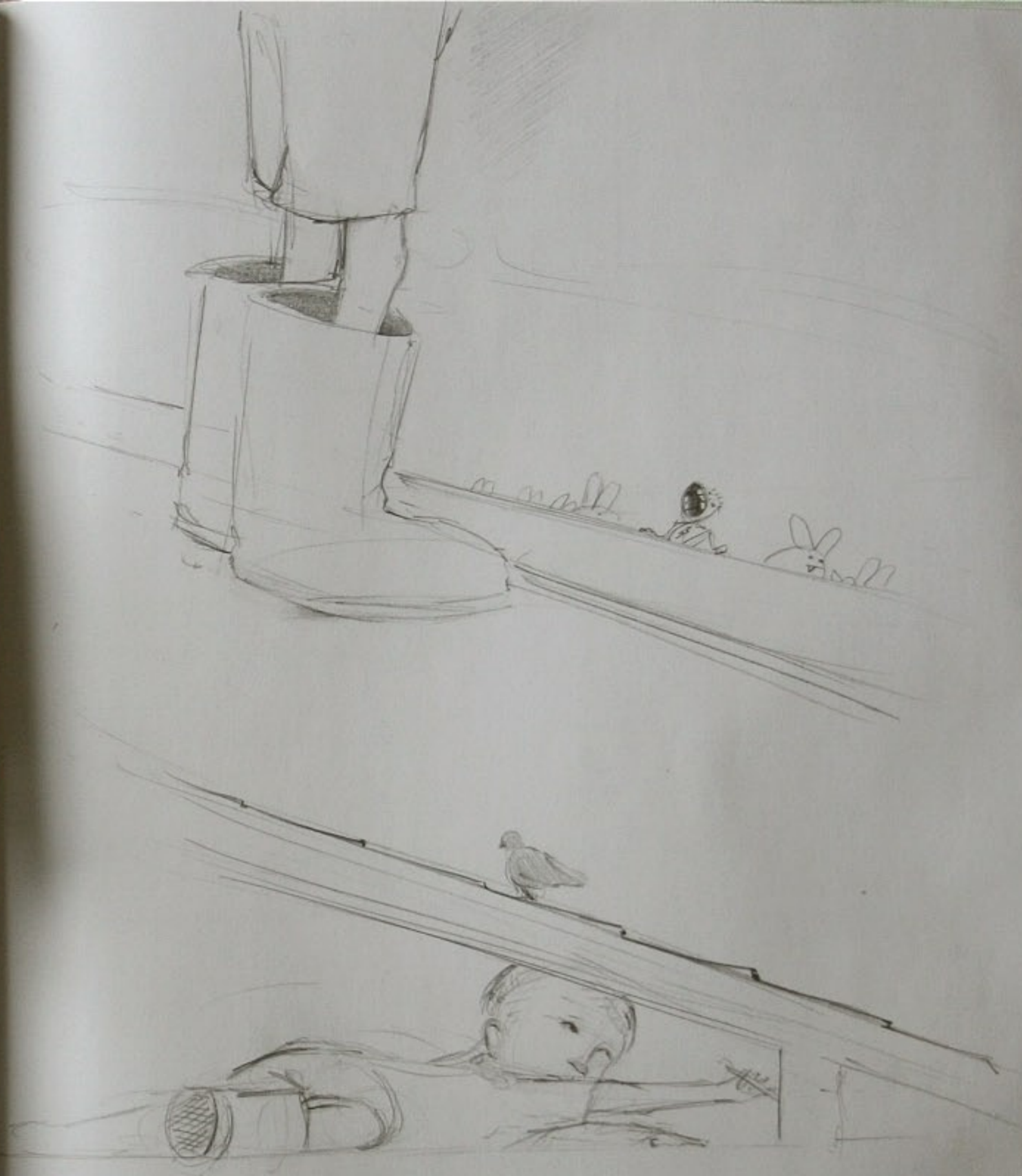
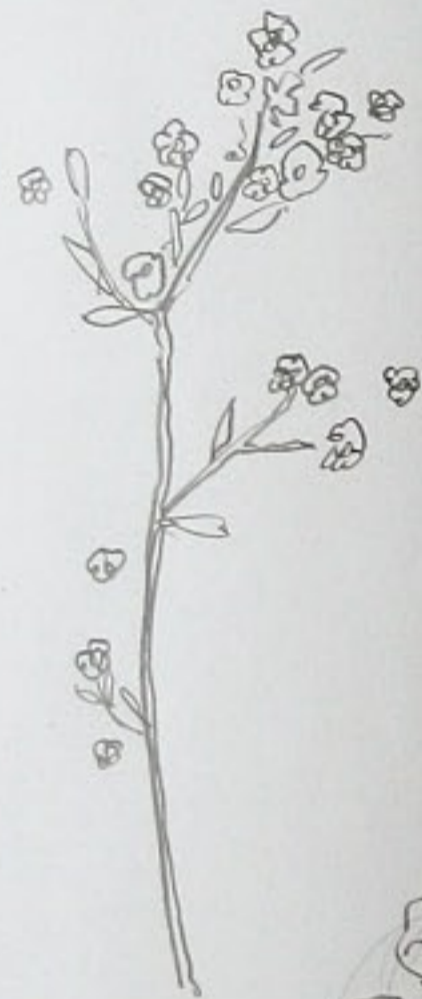

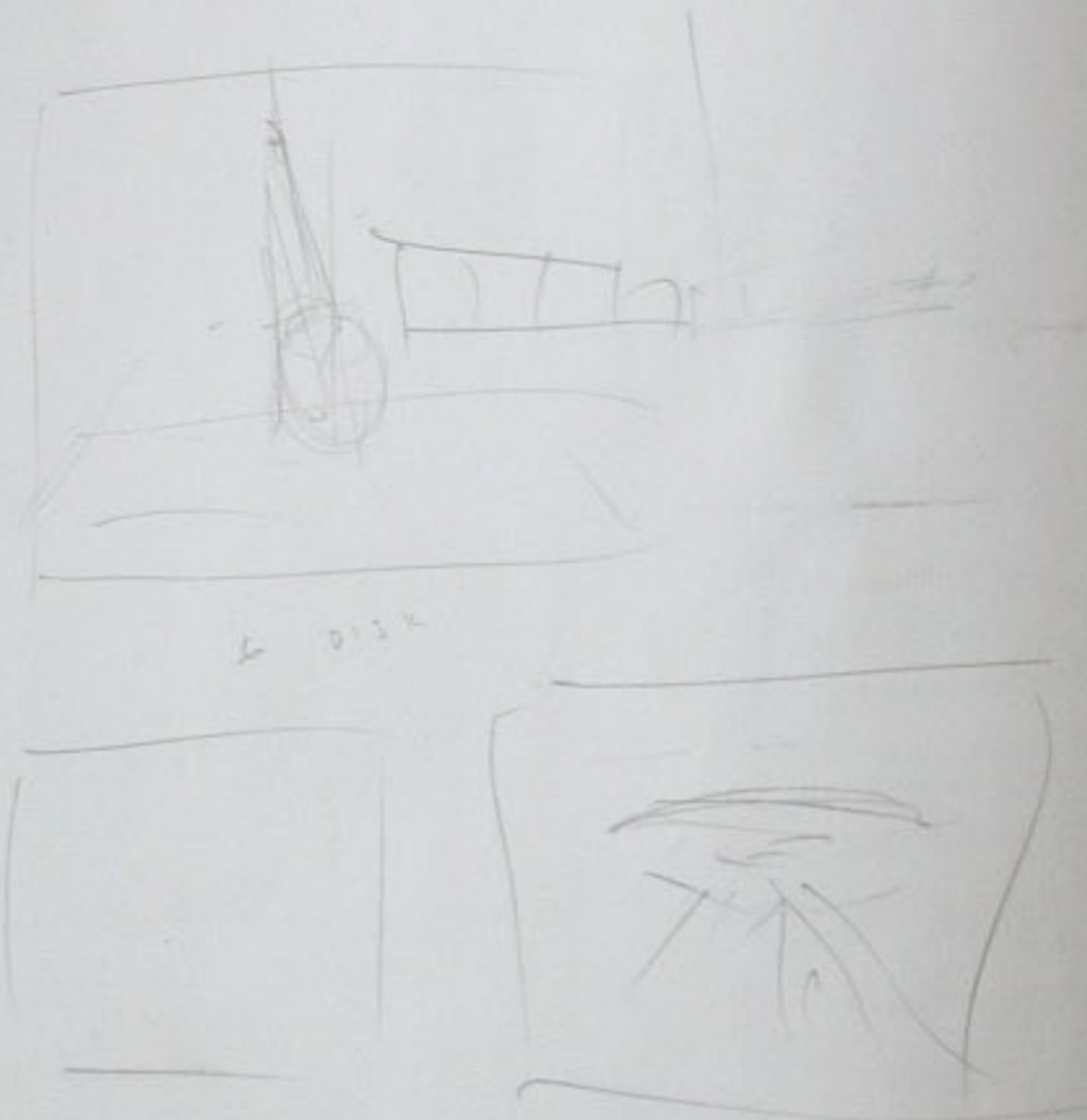

disk

TRANSITION 2 SECS

PENNY
PIANO
TRAINING
DESIGNER

FRI 26



3 REPTUG

- 4
- ④ COMMUNITY - 3 PEOPLE PLAYING GAME FEELS
 - ① CONNECTION - 2 PEOPLE SITTING LAUGHING ALLIE ROGERI
 - ② DEPTH - STACK OF BOOKS - TRISTAN
 - ③ RESPONSIBILITY - FRIDGE (COMPRESSION, MAP, RECTANGLE, FINE)
- W-NOVA 45 SECS
23:40
COOKING 15-20 SECS
PHOTO ALBUM



SEPT 12

HUMAN RESOURCES
CFL. EDU

- PLIES REFRACTION
- MOCE
- NEW TEXT IN GLASS
- 3 SECS BEFORE TICKER COMES ON THEN WIPE
- WIDER STRIKES & HAND
- "SECONDS" (EMALLED)
- PUSH IN ON PHOTOS & SWING UP
- FADE BETWEEN SHOTS

CALVERT HD STD
BIN

THREADS

WWW.THREADMEDIA.COM

THE JOBSHIP PROJECT

4500



□ PARTICLE DUST

- SHOOT (TRACK) CHILD PHOTO
 - PLANT ARROWS IN KITCHEN
 - ANIMATED MAGNETS
 - ANIMATED LOGO
- 300 \$985 2.2
18-200 \$389 TAYLOR
COW 18-55 \$25
REBEL CTI 18-55 \$299

ROGER
323 791 8885

NOOMA.COM

GIRL HOLDING GLOBE

ATTITUDE
□ BIG STRINGS

\$3000
WALLFLOWERS
3RD & FULL
MID OCT
INTRA
NOV

\$3500
OCT 1

\$4000
WEEK 3 & FULL SCREEN
WEEK 4 OCT 8
INTRA
3RD WEEK OF OCT

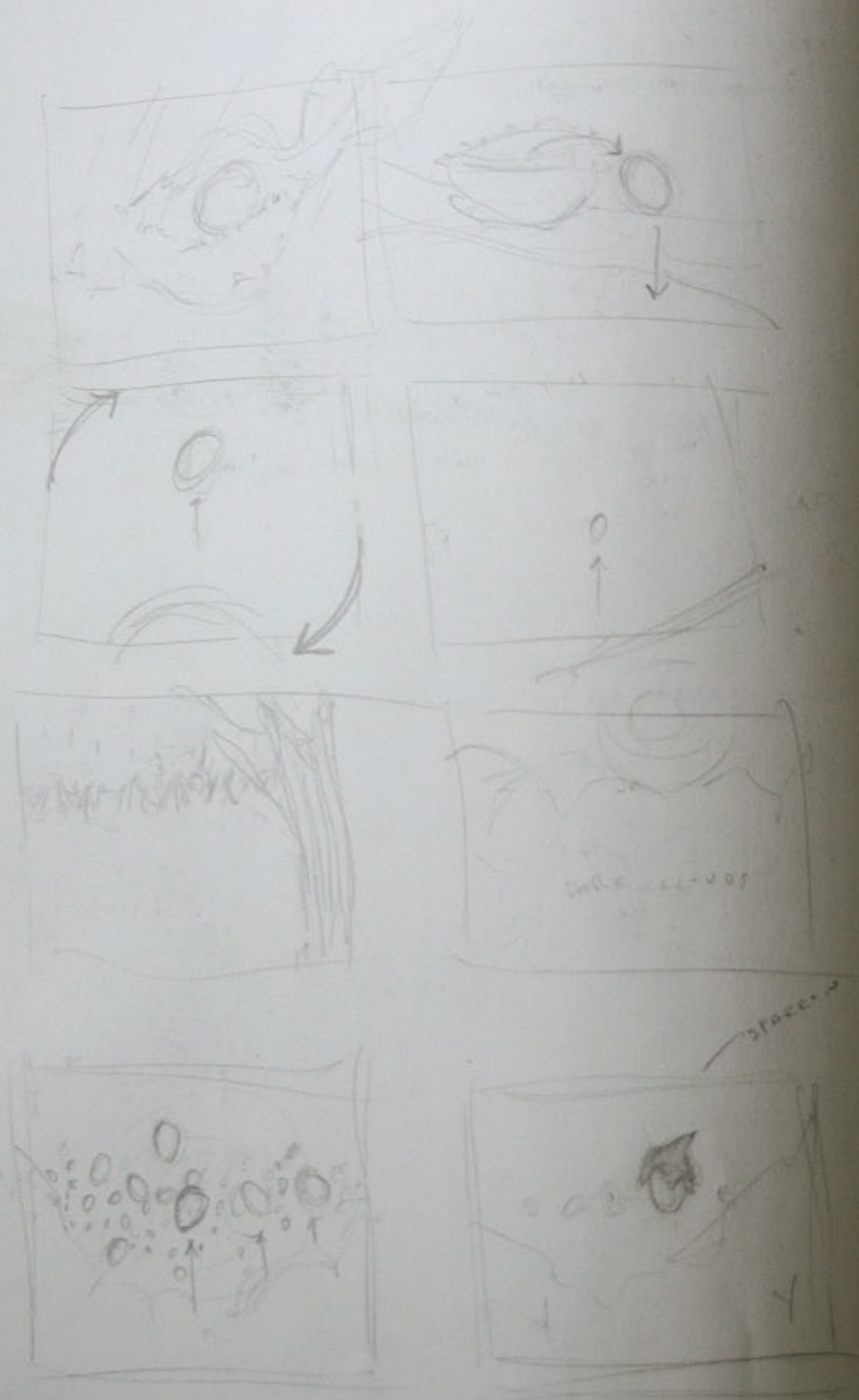

57. SUZUKI FRIDAY

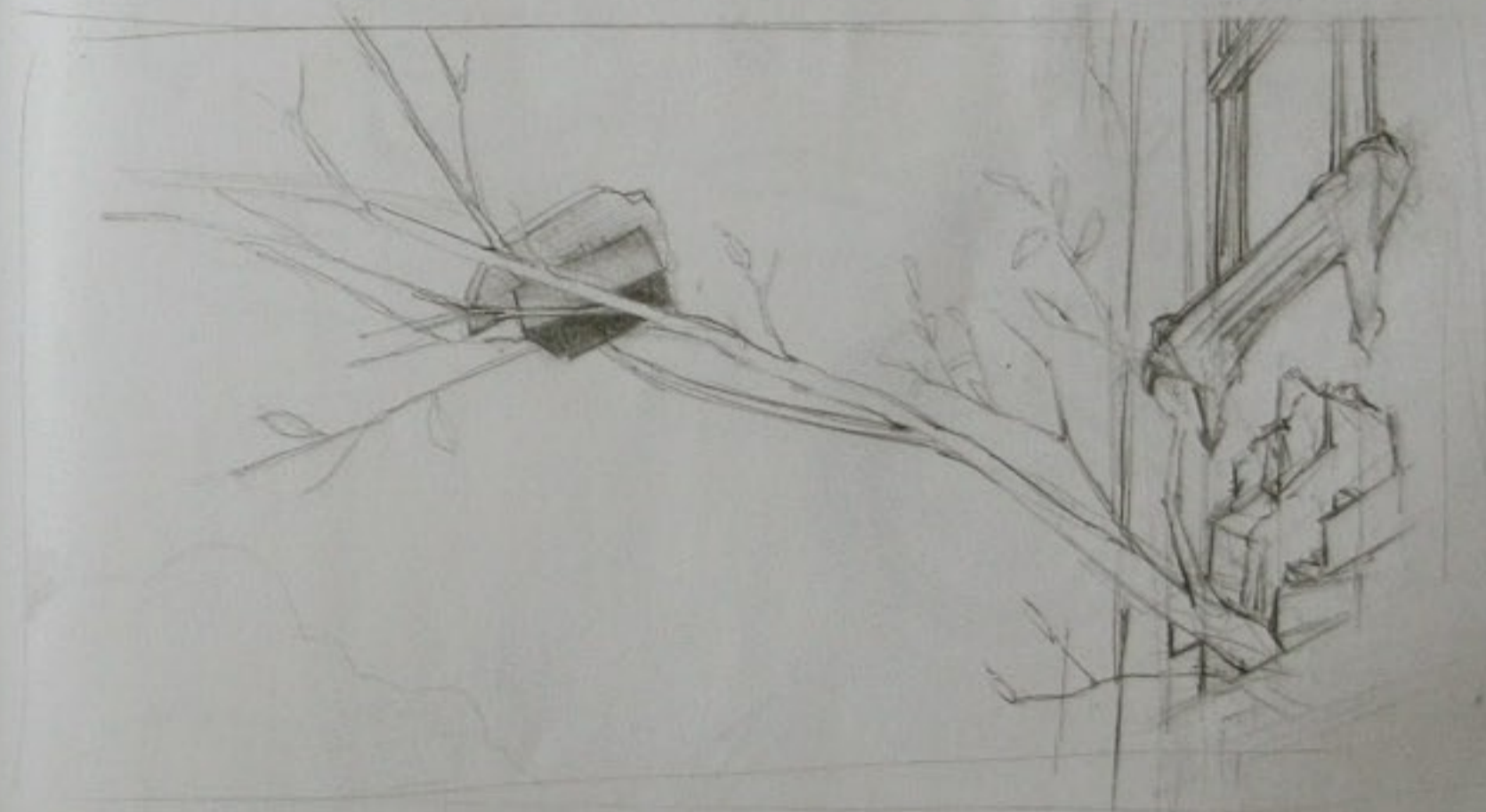

SCHOENHUT DOLLS



BLUE LINE JAZZ
 BOB KAPLAN
 JAN-FEB - STORYBOARDS
 MARCH - PRO DESIGN & PREP
 APRIL - JUNE FILM
 JULY - OFF
 AUGUST - FX & ANIMATION



SHERWIN WILLIAMS
BEFORE CHRISTMAS

TIM PARKER
261 6484
CALL AMO

FIRST -

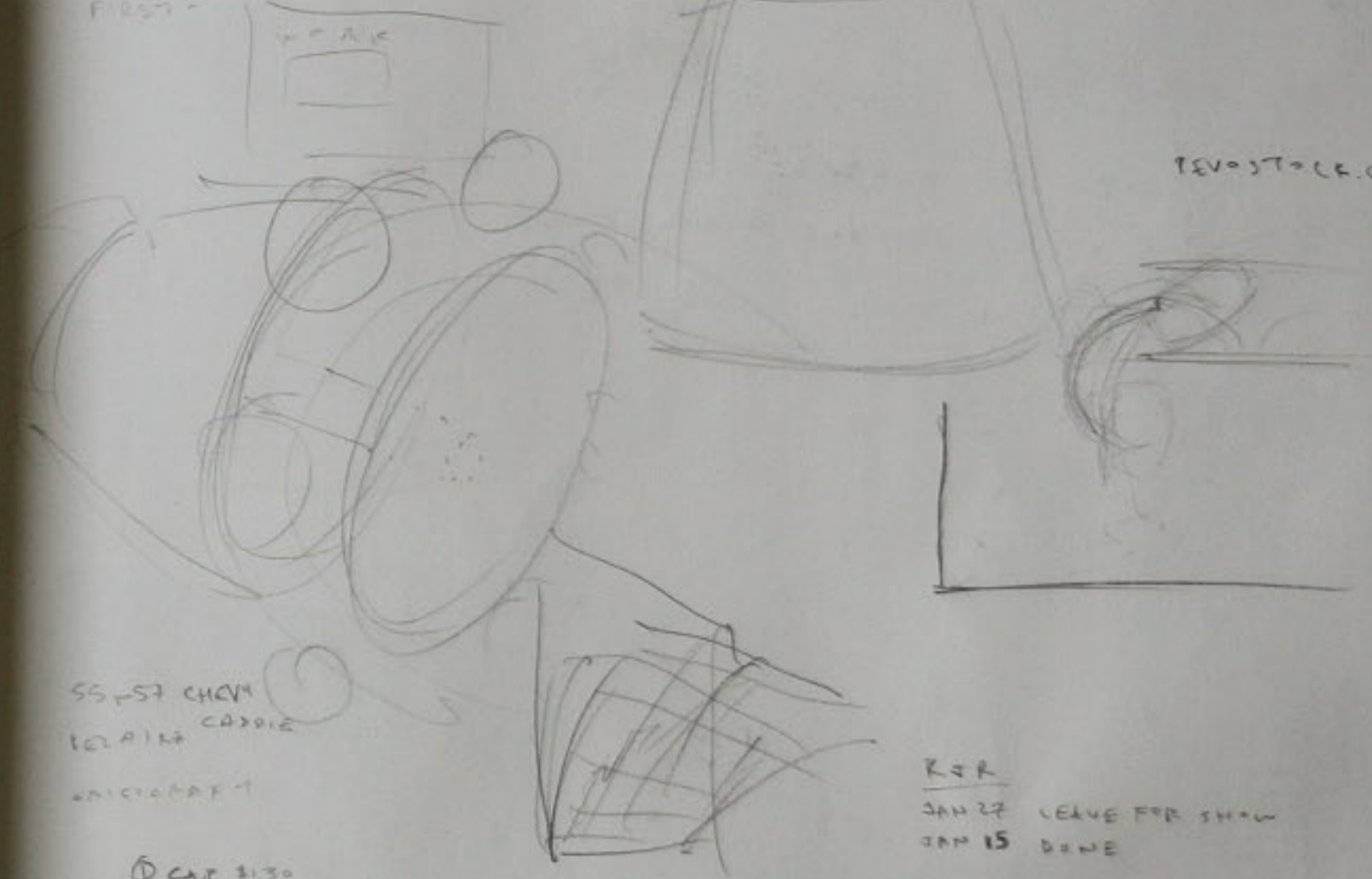

REVOSTOCK.COM

SS-ST CHYM
 RELAIN CASOIE
 UNICORP

RFR
 JAN 27 LEAVE FOR SHOW
 JAN 15 DONE

- ① CAR 1:30
- ② Boat
- ③ MACHINIST PARTS
- ④

BLACK
 PAU/SPANIC
 ASIAN
 WHITE
 MAN
 WOMAN
 CHILD
 SUBJECT
 THEM

BOB S 2 6 4 0 1



LOOK UP THERE? FOR HITMET

KEN SCHNAARS
646 3871

AFTER 3 ON SAT
2 @ 7 THRS

CL-32LS
BRIDGE - ATTACHMENT
CHART

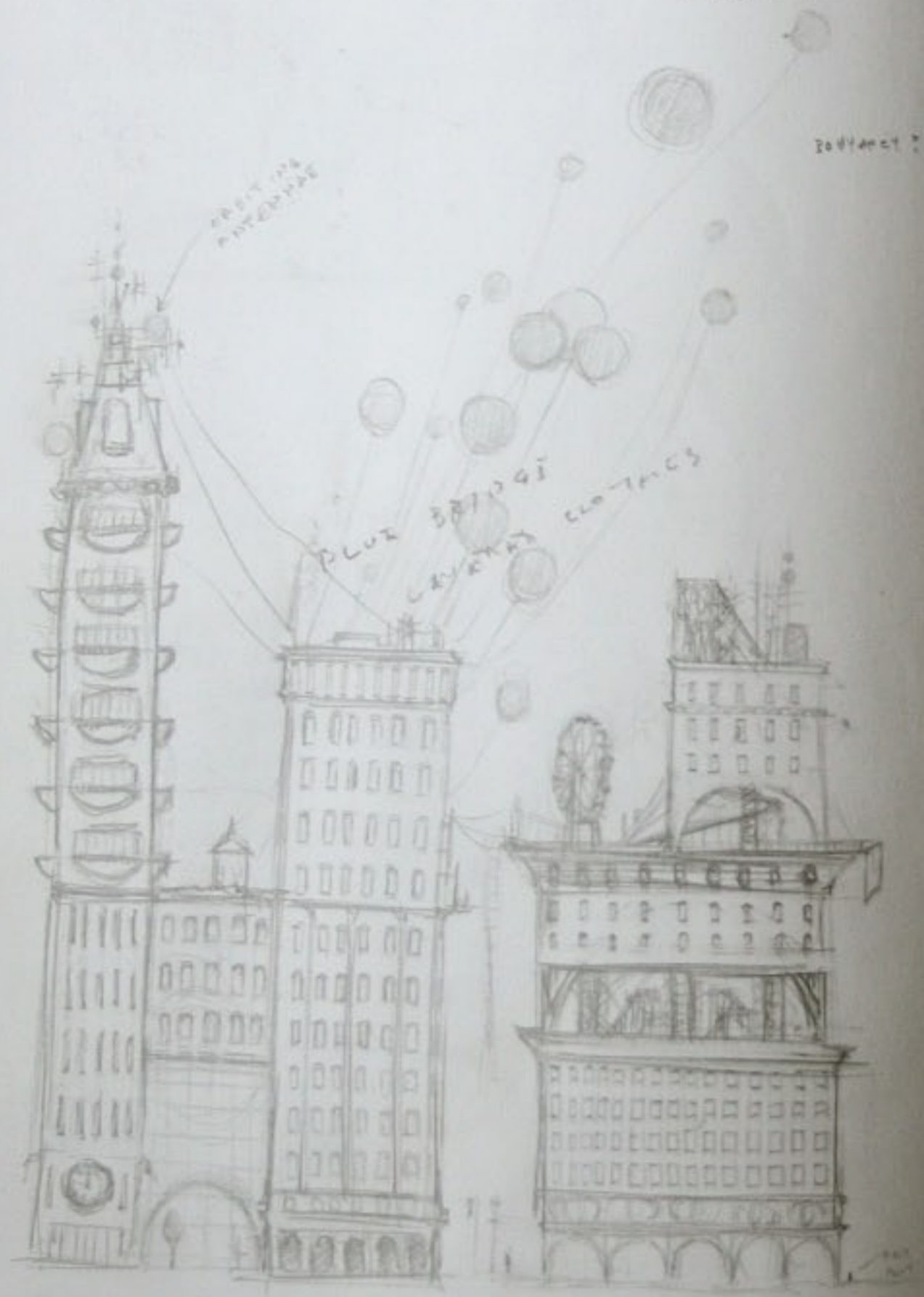

FOOTCATH 45-60
LITRIM-18N
27 V 100mah
FINEPIX 160Z

094412636
CEL TUT.

1ST DAY IN PURGATORY



FORUUS RO GERI

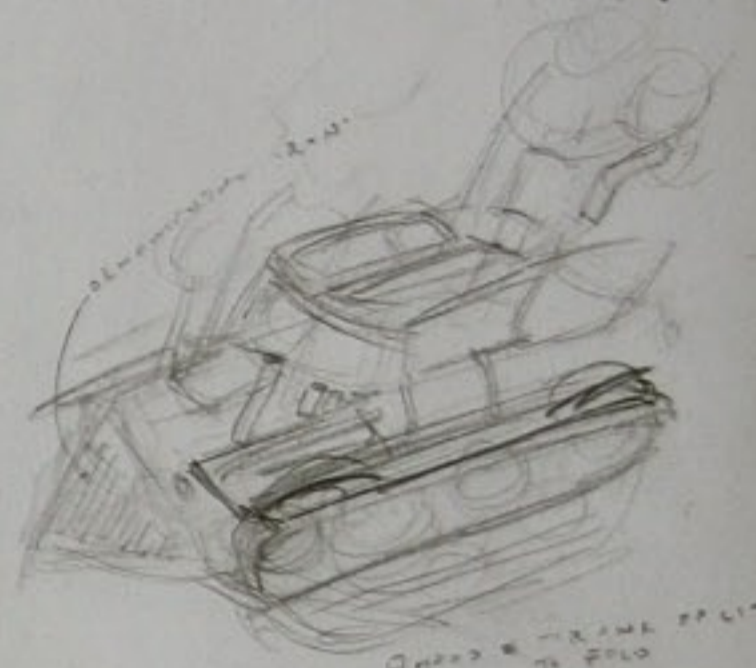
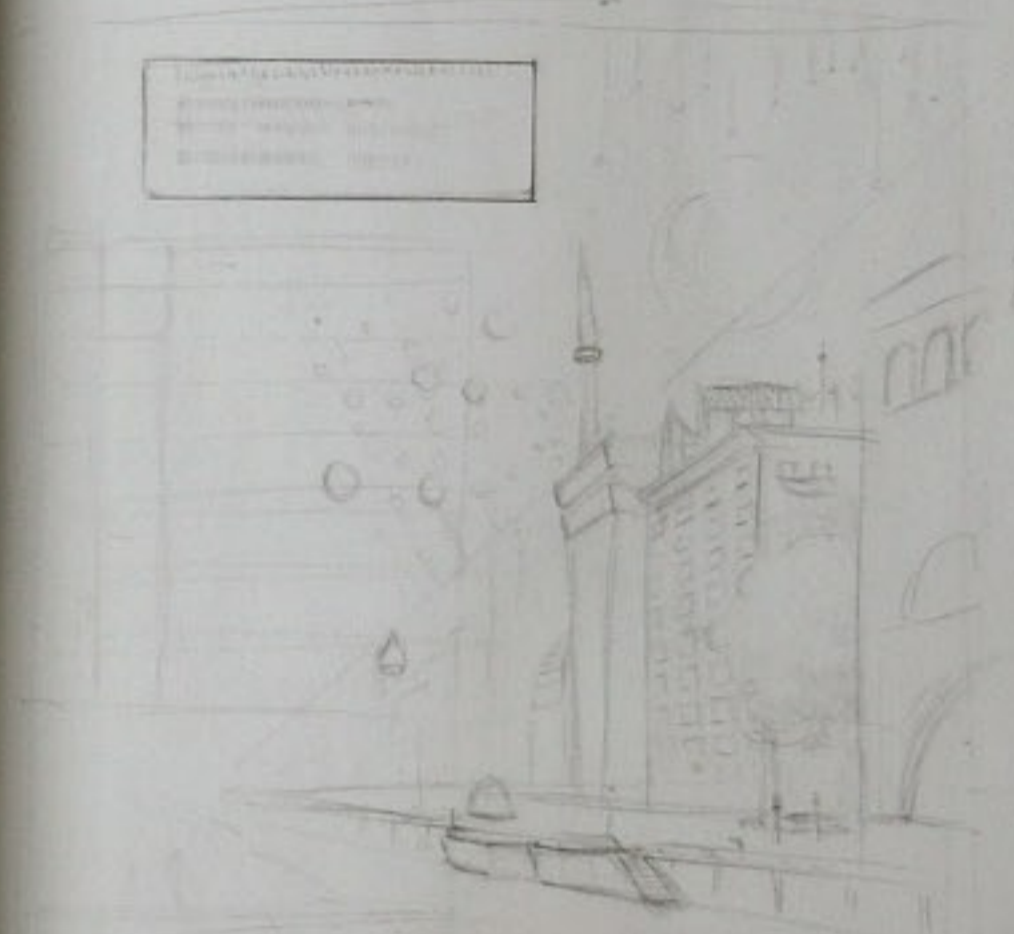

CHOP - TRAIL PLIN
TO FOLD
D WHEEL SET TO ROLL
D TRENDS HANGERS
D POSITION STOPS
FOLD UNDER TO
ACCOMMODATE TRENDS
(NOT SO HIGH)

LIST OF COMPONENTS
LIST OF MATERIALS
D WHEEL SET
D TRENDS HANGERS
D POSITION STOPS

- STAIR
- D WHEEL SET
- D TRENDS HANGERS
- D POSITION STOPS
- D CHAIR
- D PUBLIC SEAT

D = HOCKEY REG!!!

THESE
FORMS
FOR
LIFE
STRAIGHT
MUSEUM
TOUR
CATERING



Although the Happifats' fame has now faded, character-doll collectors still value them. Pat Garthoffner of the Garthoffner Gallery in Litz, PA, prices your mint-condition pair at \$450 to \$500. Their appeal is the simple, almost severe, line of the frame, which tapers to a slender foot. Edwardowski of the Tri-State Antiques Center in Allentown, PA, says the set is worth \$600 to \$800.

Michael Stern of Lamont and Stern Antiques, PA, prices your mint-condition pair at \$500 to \$600.



259.13
B7128m X
29.1333
L8.7c
(VET, WILLY)
629.892
I643 + 2002
629.892
I16r
796.15
H246c
690. CBL74c
621.52
R974w
942 W63
WREBELT

DOWN THE ASTRONAUT W/ SPACE STATION
CHESLEY BOWESTELL → ASTRONAUTS
↑
GET BOOK

SPIDERWEB P 49

ROBOT INVASION OF COOL SPRINGS
BARNES & NOBLE

COLOR PROGRESSION
TEXTURE PROGRESSION

PASTOR & DON IN ARMOR

AQUALITE BILLBOARD "MINE"

BIKE GARAGE

QUAD W/ CROWNING OF POPE
FOUND STONES

SEXY CARROT (RYDEN)

COUPLE OF SKETCHES

PLANS & SKETCH

BOARDS & CHARACTER DESIGN

SKETCHED BOARD

DESIGN STOCK PHOTO DOCTRINED WITH FIGURES & "PURE EVIL"

SKETCHES

SKETCHES

SKETCHES [K] [L] [O]



⊗ GIBBY CONDOM FAIR
⊗ SLOWLY/CHASE/FLAG BOARDS
⊗ COMPRESSION BOOTH SEQUENCE
□ COMING OUT WALL
□ WIDE SUBRENER HOUSTON CHURCH W/ PIÑATA & KIDS (PASTOR OFF TO SIDE)

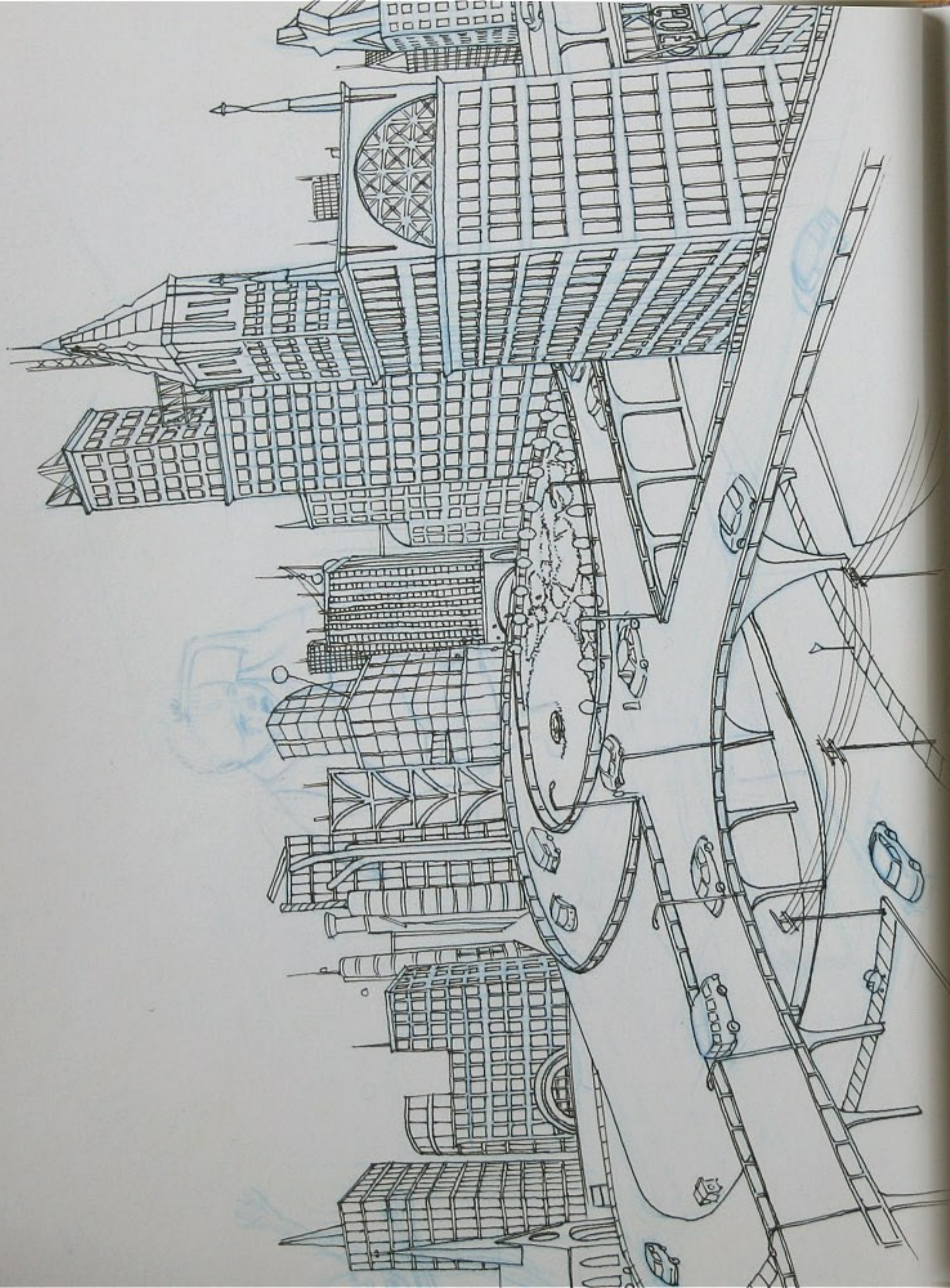

HOME
 MUSIC VIDEOS
 COMMERCIALS
 PRODUCTION SERVICES
 FILM
 TELEVISION
 INFORMATION (NEWS)

BRAD
 HERE @ RUCES
 MON 25TH

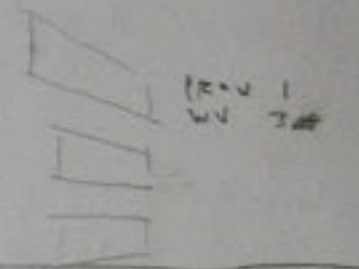

GRAB (BRAND)
 8 FRAMES @ HEAD
 BRING SHOT OUT WITH 1 & 2
 FIG CHED ONE OUT MORE & LIGHTEN
 LIGHTEN BACKGROUND DOCUMENT & BLUR
 BRING 'AIDS' IN WHEN 1ST SYMPTOMS LAND
 ADD MOVE UP TO DOCTORED TOP PAGE @ END
 ADD 30 FRAME TAIL

AIDS:



HANS

f

ISAR KOKSHAR BAH BALADAH-LAP



F
MORE
FILL
ROTATIONS

NICK ALRIGHT

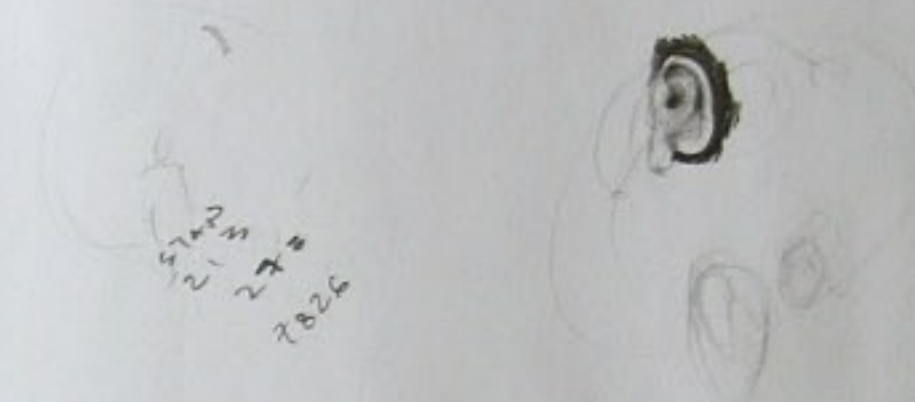

2/22/2024

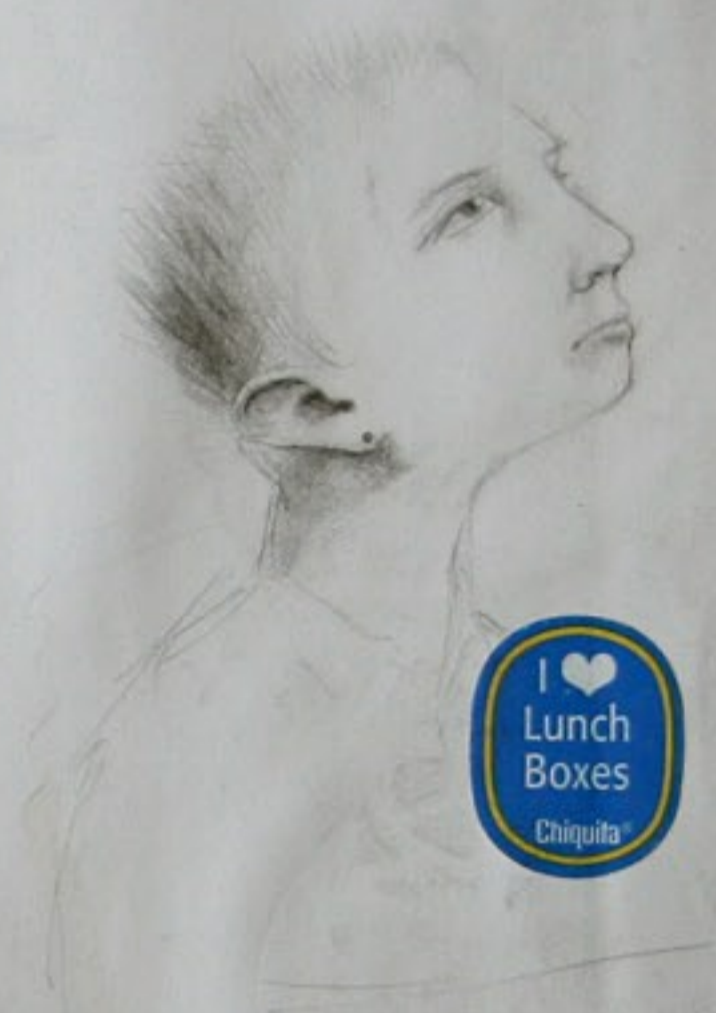

- ① ARDECAI & ESTHER (HAMAU)
- ② ESTHER & KERES
- ③ ESTHER, HAMAU, & KERES
- ④ ESTHER, HAMAU & KERES



Rice

MAP SET
-CAM

WE ARE FLIGHTLESS BIRDS



STRUGGLE TO FIND
MEANING / PURPOSE
SOME BEER FOR
TO FIND WAY OUT
SHE STAY TO FIND
INGREDIENTS
ZEEDER IS A SMALL
HEALER
MAUS CONVINCED HER TO
HE & HIM GET OUT
MATTER GOES WITH TO
BRING THEM BACK,
BECAUSE THERE'S SO
MUCH TO DO WHERE THEY
WERE
STILLERY T-DS TRUST-
INTERPRET EVERYTHING
FROM AFAR, BUT HAS
TO COME IN ORDER
TO LIVE
MISS MAUS IS HOLDING
ZEEDER REMEMBER
DREAMS
ZEEDER DREAMS OF
HER PARENTS GIVING
HER UP
CRABBY & MECHANIC
HAS TO FIND MEANING
AFTER MAUS LEAVES
HIM. BECOMES
FRIENDLY WITH
JUST
PARTICIPATES
IN ENTERTAINING
SERVES: FALSE
PURPOSE
EAST
TO FOLLOW SPIKE HESITATES
& HAS TO ACT WITHOUT
THINKING → THE
FIRST ANSWER IS
USUALLY RIGHT
WHEN YOU ARE NOT
IN A MIDDLE.

1460 CAMPBELLTON HIGHWAY
36301

CURTIS IS
T-VERTICAL
ST.MUS
AS
STICKY TOON
IS TO
ELEGANT
EVENING



SHADOWS
+ ENERGY
BLISSOMS

ASK QUESTIONS
LIKE A CHILD ASKS
PLEAD FOR A SIGN
OF THE UNDESCRIBABLE

FIREWORKS

JOHN GREER
MAY 6 407
IN NASHVILLE

1305 CLINTON ST
SUITE 100

U.M. 11:10



Eh

-CLASS LIST
-GOD & MUSIC CITY
(L.A.S.)





ISHPI



4.^{ta} SOPHONAS

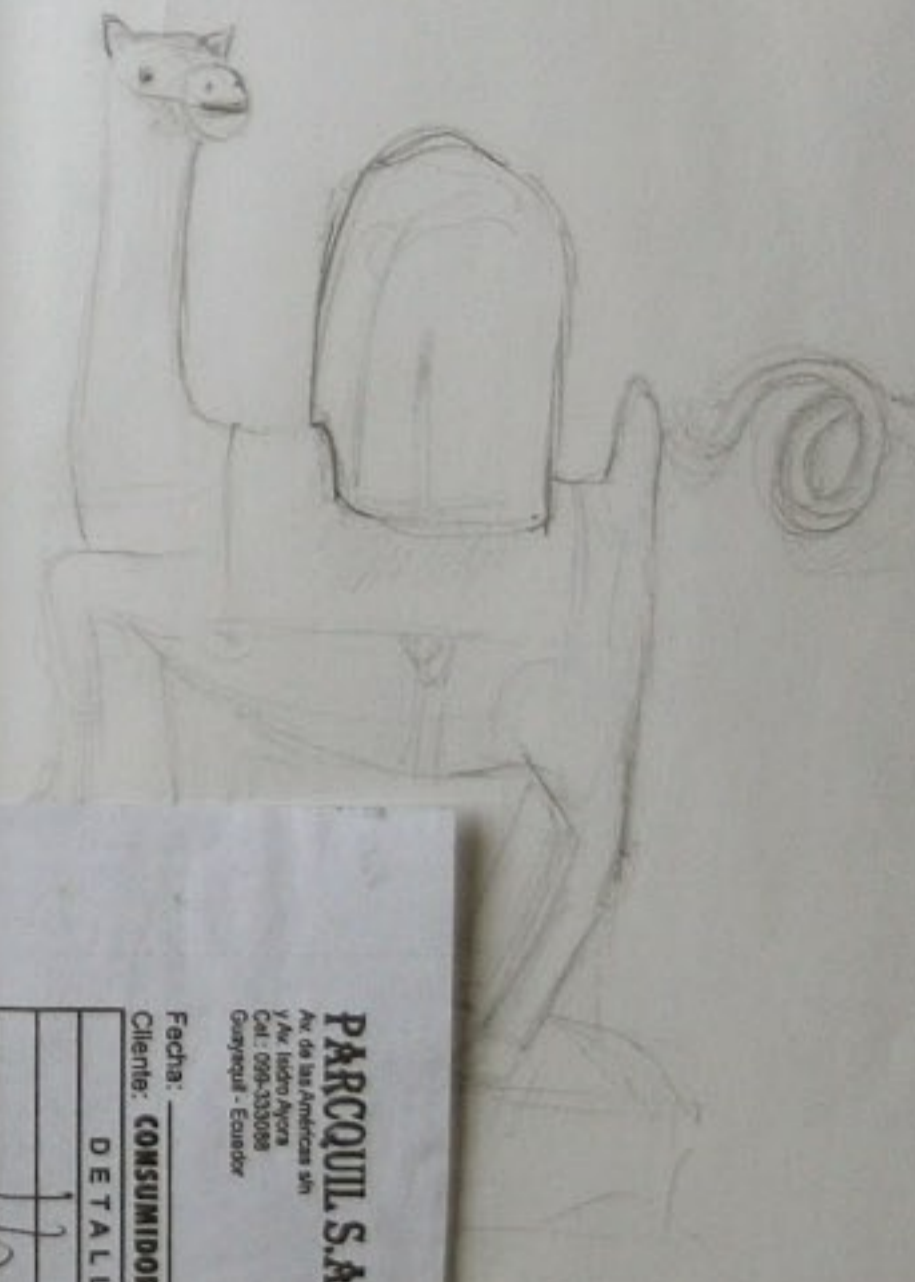

ISHPI

PARCOUIL S.A. R.U.C. 0992444000001
Av. de las Américas s/n
Yak. Ibarra Ayra
Cali: 0985-533088
Guayaquil - Ecuador
No 069332
Autorización SRI 1108702380
506.08
Fecha: _____
Cliente: CONSUMIDOR FINAL

| DETALLE | VALOR |
|------------------|-------|
| H | |
| | |
| | |
| | |
| Valor Total US\$ | |

PARCOUIL S.A. - DISTRIBUIDOR DE PRODUCTOS DE CALIDAD EN EL ECUADOR - SIN SERVICIO AL CLIENTE - SIN SERVICIO AL CLIENTE - SIN SERVICIO AL CLIENTE



Esther 30

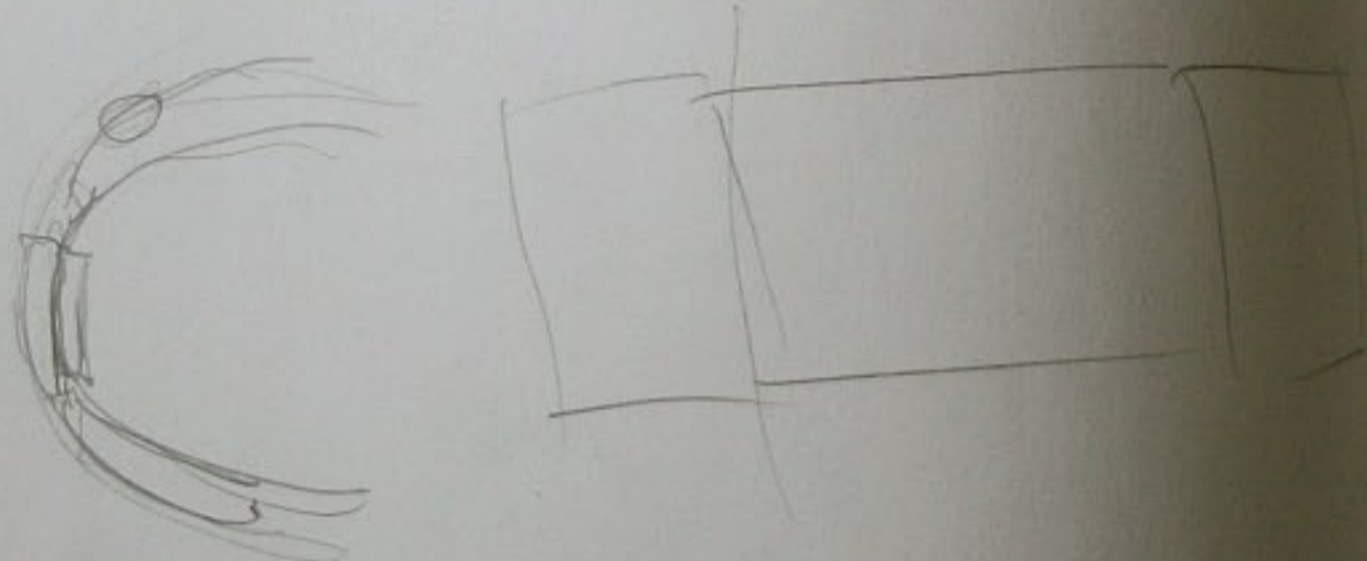
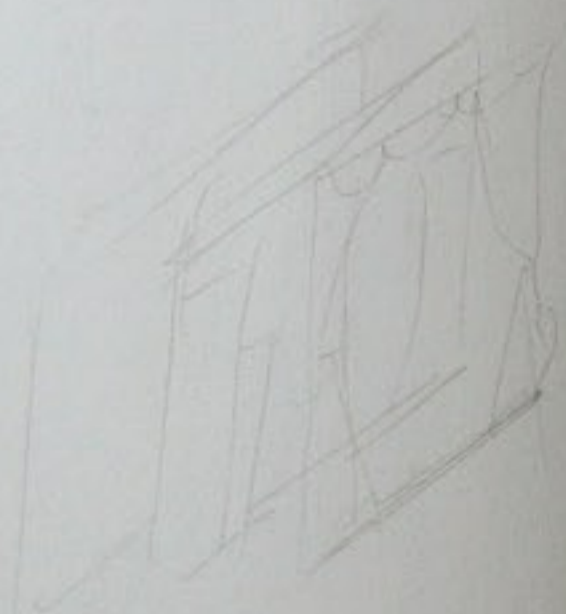

1 pg.

- Name
- Contact info:
- Cell. #
- e-mail?
- Older photo
- Article
- Philosophy → 3 sentences

- ① TEACHER → SYDNEY
- ② GUY CELS CAVE
- ③

GO MEDIA

GREG MCHICEL



140
91-00

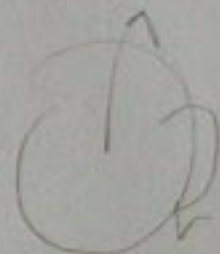

New Tooth

←...→

706 HENRY
AVERT IPA



423 8229
533 2629
LEFT FOR

- HOSTING COSTS & SITES
- SERVICE CONTRACT
- PUSH US ON MIDDLE CIRCLE
- IDENTIFIERS FOR CONTENT

CENTRE
KALEIDOSCOPE

STOCK
DREAMTIME.CH

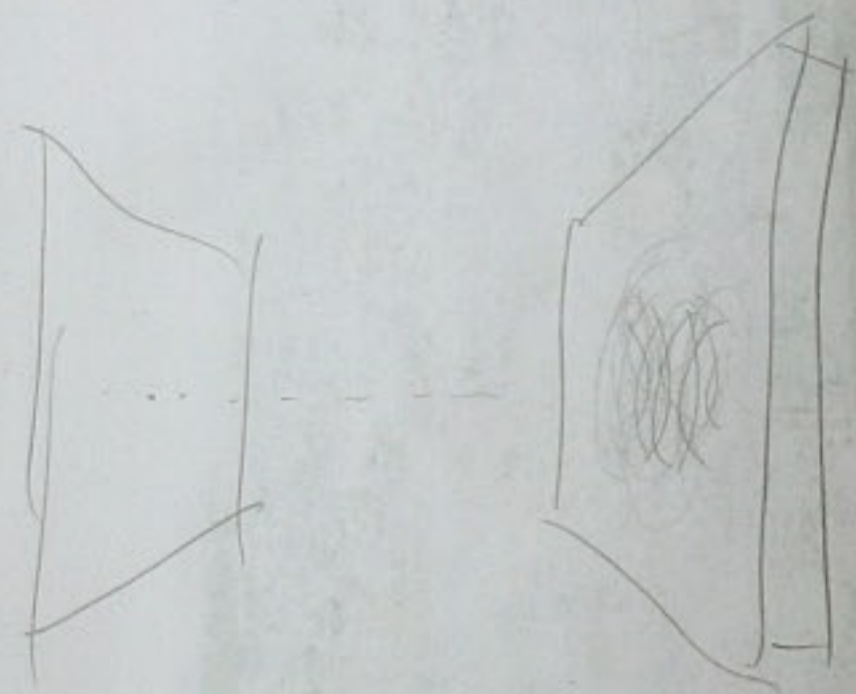

932 VS311
J972 K99PA
J909 P989P
JAMES RUTMAN

MR. ART

DEBRA WALTON
337 3839



HOUSE → TREES → FENS →
OUT → CHURCH →
FIELD w/ SPARSE TREES →

BADA
YAAA

PORTCART
774.71041 K363L
376.802 2725c

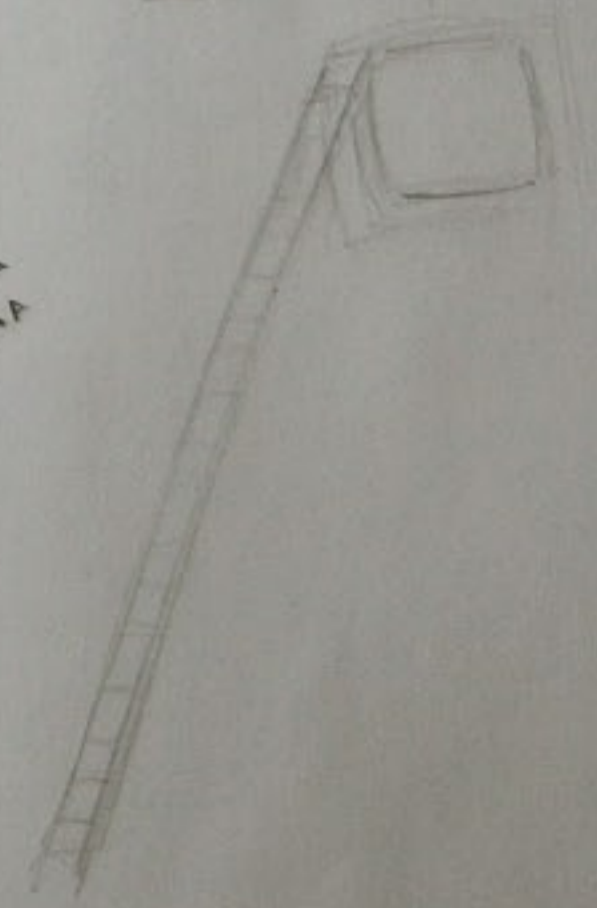

TUMBLER
SEND EVERYBODY
THE FULL SCENE
WEBSITE

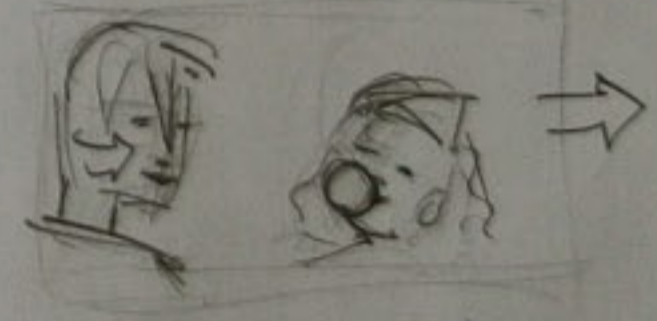
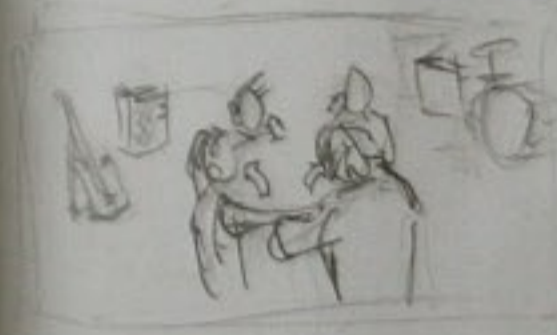

DIAGRAM
 1. EAST SIDE OF THE AVENUE

- ◻ 2 DIFFERENT PERFORMANCES
- ◻ NASHVILLE ART LIVE
- ◻ SCRIPS, CITIES FOR TRUCK TO RIDE THROUGH
- ◻ OLD BERT OF HULL
- ◻ KITCHEN AND
- ◻ BARNFIELD
- ◻ FAIRY
- ◻ CRYSTAL
- ◻ FIRE AT WIDE

CLASS (EP = MAKE
 CARIM = DARK EPAD (LOW THROUGH BLOOD)
 FUSE = ELIMINATE MOUNTAIN
 REY

BELLEVUE



MAKE DESIGN
 4003584

WHATTA MESS!

- ◻ 2 DIFFERENT PERFORMANCES
- ◻ NASHVILLE ART LIVE
- ◻ SCRIPS, CITIES FOR TRUCK TO RIDE THROUGH
- ◻ OLD BERT OF HULL
- ◻ KITCHEN AND
- ◻ BARNFIELD
- ◻ FAIRY
- ◻ CRYSTAL
- ◻ FIRE AT WIDE

WOMEN'S DAY APP
 ENTER INTO THE APP